

HONDA

**Honda Lawn Mower
Owner's Manual
&
Service Record Booklet**



HRU19M2PKU



HRU196M2PWUH



HRU196M2PBUH



HRU216M3TBUH



Read and understand this Owners Manual before operating your Honda mower and ensure that you have identified the information applicable to your particular model mower.

Thank you for purchasing a Honda lawn mower.

This manual covers the operation and maintenance of the new Honda Premium & Pro lawn mower range.

We want to help you get the best results from your mower and to operate it safely. This manual contains the information on how to do that; please read it carefully.

This manual should be considered a permanent part of the lawn mower and should remain with it, if it is resold.

If you have a problem or questions concerning the mower, contact your nearest Authorised Honda Power Equipment Dealer.

SAFETY MESSAGES

Pay particular attention to statements preceded by the following words:



DANGER

You WILL be KILLED or SERIOUSLY HURT if you do not follow instructions.



WARNING

You CAN be KILLED or SERIOUSLY HURT if you do not follow instructions.



CAUTION

You CAN be HURT if you do not follow instructions.

Each message tells you what the hazard is, what can happen, and what you can do to avoid injury.

DAMAGE PREVENTION MESSAGES

You will also see other important messages that are preceded by the following word:



Your lawn mower or other property can be damaged if you do not follow instructions.

The purpose of these messages is to help prevent damage to your lawn mower, other property or the environment.

Do not use this lawn mower for any purpose other than mowing lawns.

Illustrations in this manual are for instructional purposes only and may not be exact representations. All information contained in this manual is based on the latest product information available at the time of publication. Honda Australia Motorcycle and Power Equipment Pty. Ltd. reserves the right to make changes at any time without notice. No part of this publication may be reproduced, stored in a retrieval system or transmitted in any form by any means, electronic, mechanical, photocopying, recording or otherwise, without the prior written permission of Honda Australia Motorcycle and Power Equipment Pty. Ltd. This includes text, figures and tables.

Honda Australia Motorcycle and Power Equipment Pty. Ltd.

ABN 96 006 662 862 (trading as Honda MPE).

CONTENTS

1. WARRANTY	4
Honda Limited Warranty	4
2. SAFETY INSTRUCTIONS	5
3. COMPONENT IDENTIFICATION	7
4. CONTROLS	8
Fuel Valve	8
Throttle Lever	9
Blade Controls	10
Drive Clutch Lever	10
Cutting Height Adjustment Lever	11
Shift Lever	11
Front guard	12
5. PRE-OPERATION CHECKS	13
ARE YOU READY TO MOW?	13
CHECK YOUR LAWN	13
CHECK YOUR MOWER	14
Blades	14
Engine Oil Level	17
Fuel	18
Air Cleaner	19
Grass Catcher	19
Mulch Plug Installation	21
Cutting Height	22
6. OPERATION	23
MOWING PRECAUTIONS	23
STARTING THE ENGINE	23
Throttle Lever	26
Blade Control Lever	27
STOPPING THE ENGINE	28
SAFE MOWING PRACTICES	29
MOWING TIPS	31

7. TRANSPORTING/STORAGE	34
BEFORE LOADING	34
LOADING AND UNLOADING	35
STORAGE PREPARATION	35
Handlebar Folding	39
STORAGE PRECAUTIONS	40
8. MAINTENANCE	41
THE IMPORTANCE OF MAINTENANCE	41
MAINTENANCE SAFETY	42
MAINTENANCE SCHEDULE	43
ENGINE MAINTENANCE	44
Engine Oil Change	44
Engine Oil Recommendations	45
Air Cleaner Service	46
Spark Plug Service	47
Carburettor Modification for Altitude operation	49
Fuel Recommendations	49
BLADE REMOVAL & INSTALLATION	50
GRASS CATCHER CLEANING & REPLACEMENT	56
9. TROUBLESHOOTING	57
10. SPECIFICATIONS	59
11. SET UP INSTRUCTIONS	62
12. SERVICE SCHEDULE SHEET	63

1. HONDA limited WARRANTY

Honda* warrants each new Honda lawn mower to be free from defects in material and workmanship for the period detailed on your warranty registration form.

The Honda warranty is limited. In order to qualify, the service schedule sheets located at the back of this manual must be completed. Any Authorised Honda Lawnmower Dealer will repair any part that proves defective within the limits of this warranty at no charge to the owner for parts and labour. All parts replaced under this warranty become the property of Honda. Transportation costs for the product either to or from the dealer are the responsibility of the owner.

This warranty will not apply to:

- Any part, which has been subject to misuse, negligence, accidental damage, improper or inadequate maintenance, or improper storage.
- Repairs rendered necessary by or arising from, the use of other than genuine Honda parts.
- Normal maintenance items, including, but not limited to, adjustment and cleaning of carburettor, fuel strainer and air filter.
- Normal replacement of service items, including but not limited to spark plug, air filter and cutting blades.
- Deterioration of any item due to normal use, fair wear and exposure unless due to a defect in material or manufacture.
- Any work or adjustment performed by persons other than Authorised Honda Lawnmower Dealers, nor damage resulting from the same.

The benefits conferred by this warranty are in addition to all other rights and remedies in respect of the product, which the purchaser has under the Australian Consumer Law and/or any relevant State or Territory Acts. Where permitted, the liability of Honda shall be limited, at its option, to the repair or the replacement of the mower.

NOTE: For full details of the Honda Warranty policy, coverage and conditions please go to www.honda.com.au and select the Power Equipment range.

***Honda is:** Honda Australia Motorcycle and Power Equipment Pty. Ltd.
ABN 96 006 662 862, Private Bag No. 19, Somerton, Victoria, 3062.
These warranty conditions apply to Australia only. Purchasers in other countries should refer to their local distributor for warranty conditions.

2. SAFETY INSTRUCTIONS

WARNING

1. Never mow while barefoot or wearing open sandals, or thongs. Wear long trousers and heavy shoes.
2. Know your controls. Read the owner's manual carefully. Learn how to stop the engine quickly in any emergency.
3. Make sure the lawn is clear of sticks, stones, bones, wire and debris. They could be thrown by the blade.
4. Stop the engine and disconnect spark plug wire before clearing blockages, checking or working on the mower.
5. Before using, always visually inspect to see that blades, blade bolts and cutter assembly are not worn or damaged. Replace worn or damaged blades and bolts in sets to preserve balance.

NOTE: DAMAGED BLADES AND WORN BOLTS ARE MAJOR HAZARDS.

6. Check all nuts, bolts and screws often; always be sure the mower is in safe operating condition. Use only replacement parts made and guaranteed by the original manufacturer of your mower.
7. Refuel outdoors only. Do not smoke while fuelling engine. Add fuel before starting the engine. Never remove the cap off the fuel tank or add petrol while the engine is running or the engine is hot. If petrol is spilled, do not attempt to start the engine but move machine away from the area of the spill and avoid creating any source of ignition until petrol vapours have dissipated.
8. Do not mow whilst people, especially children or pets are in the mowing area.
9. Replace worn or faulty silencers.
10. Mow only in good daylight.
11. Never use the mower unless the grass catcher or guards provided by the manufacturer are in position.
12. Start the engine carefully with feet well away from the blades.
13. Do not operate engine in a confined space where exhaust fumes (carbon monoxide) can collect.
14. Stop the engine whenever you leave the mower, even for a moment.
15. Do not allow children or people unfamiliar with these instructions to use the mower.
16. Store the mower in a well-ventilated room away from naked flames which may be found in hot water heaters.

2. SAFETY INSTRUCTIONS

17. Do not over-speed the engine or alter governor settings. Excessive speed is dangerous and shortens mower life.
18. It is advisable to wear suitable eye protection when operating a mower.
19. Turn the fuel off at the conclusion of mowing and reduce the throttle setting during engine run-out.
20. Store fuel in a cool place in a container specifically designed for the purpose.
21. Stop the engine, disconnect the spark plug and inspect the mower if—
 - (a) the mower begins to vibrate abnormally.
 - (b) after striking a foreign object.
22. Never cut grass while walking backwards.
23. Stop the engine before pushing mower across gravel drives, walks or roads.
24. Walk, never run.
25. Mow across the face of slopes, never up and down. Exercise extreme caution when changing direction on slopes. Do not mow excessively steep slopes.
26. Never pick up or carry a mower when it is operating.

NOTE: Reproduced, in part, from AS2657 - 1985 with the kind permission of the Standards Association of Australia.

3. COMPONENT IDENTIFICATION

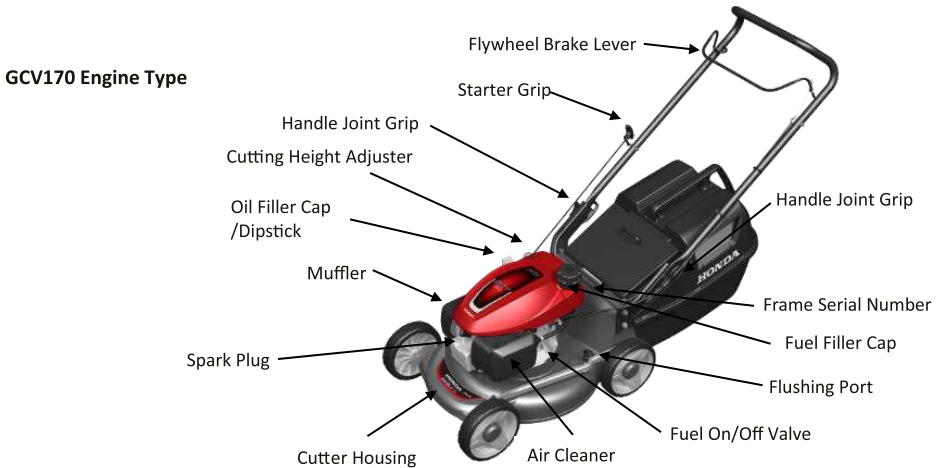
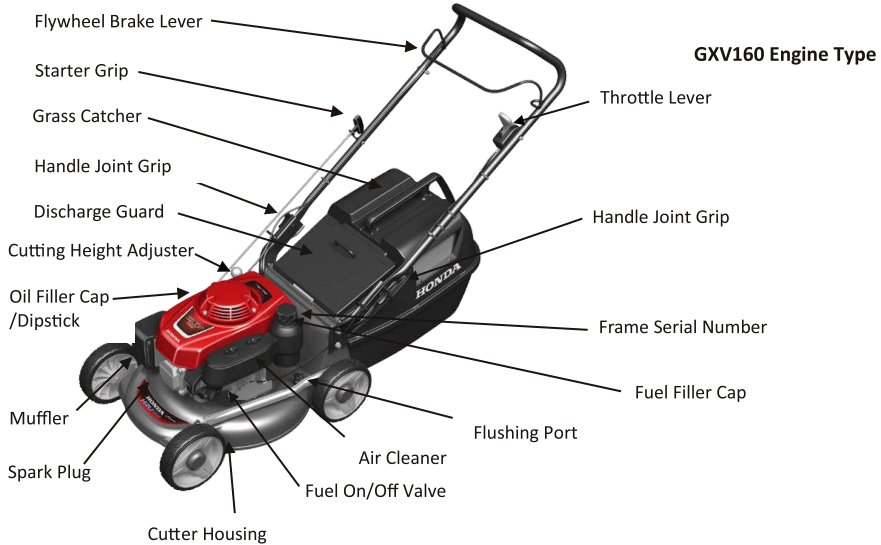

Record the frame and engine serial numbers and date of purchase in the space below. You will need this information when ordering parts and when making technical or warranty inquiries.

Frame Serial Number: _____

Engine Serial Number: _____

Date of Purchase: _____

4. CONTROLS

DESCRIPTION OF CONTROLS

Fuel Valve

The fuel valve opens and closes the fuel passage from the fuel tank to the carburettor. The fuel valve must be ON to start and operate the mower. The fuel valve should be kept OFF when the mower is not in use.

GXV160 Engine Type

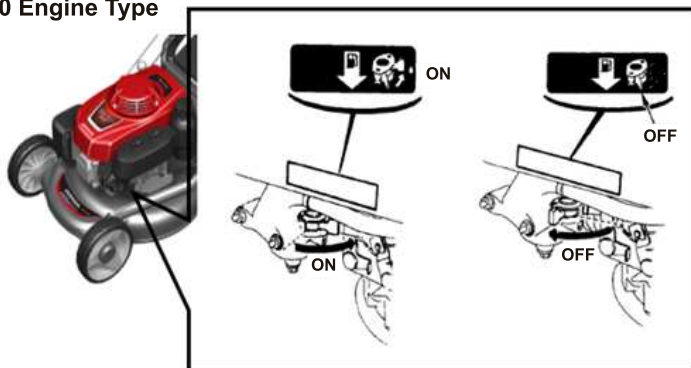

GCV170 Engine Type

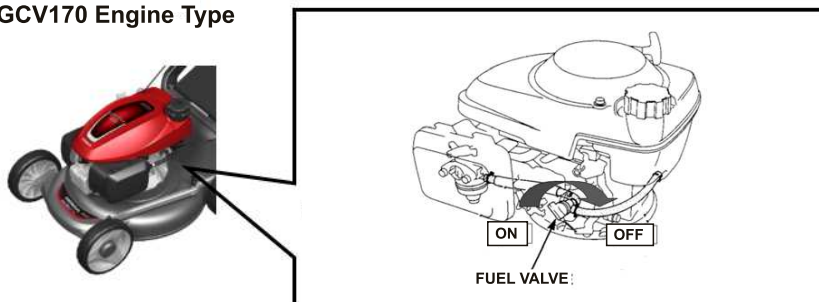

Throttle Lever (HRU196M2 PBUH & HRU216M3 TBUH)



CHOKE.....For starting a cold engine (If fitted to your Mower)

HIGH.....For restarting a warm engine and for mowing

LOW.....For idling the engine

STOP.....To stop engine (May be fitted to Brake lever)

Throttle Lever (HRU196M2 PWUH only)



CHOKE.....For starting a cold engine (If fitted to your Mower)

HIGH.....For restarting a warm engine and for mowing

LOW.....For idling the engine



(Note: Stop is located on brake lever for HRU19M2 PKU & HRU196M2 PWUH models)

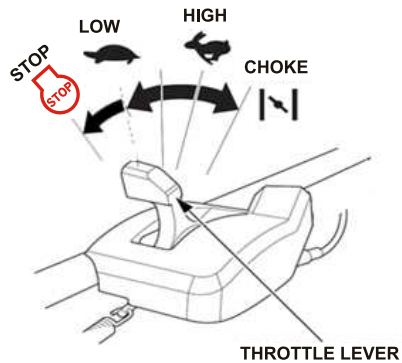

4. CONTROLS

Blade Control Lever (HRU196M2 PBUH & HRU216M3 TBUH)

This lever is connected to the Roto-Stop blade control system. The blades will not turn unless the blade control button is pushed in conjunction with the blade control lever being pushed forward.

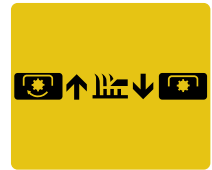
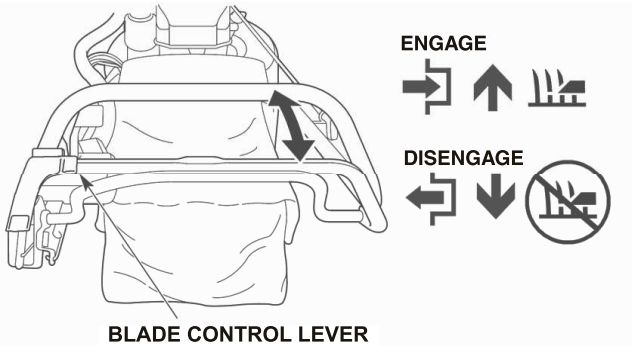

Drive Clutch Lever (HRU216M3 TBUH Only)

The drive clutch lever engages (push forward) and disengages (release) the transmission that drives the rear wheels. The drive clutch lever should only be engaged after the engine has been started.

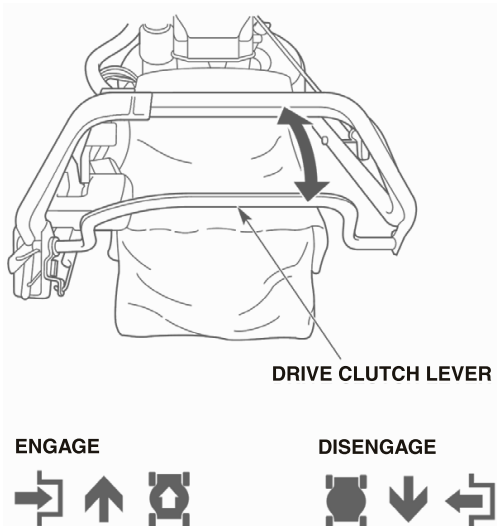

Cutting Height Adjustment Lever

All wheels of the mower can be adjusted with one lever.

The cutting height figures are approximate. The actual height of cut grass will vary with lawn and soil conditions.

Move the adjuster forward to lower and back to raise the cutter housing.

21" Approx. Height

Position	Approx Height
①	76 mm
②	70 mm
③	64 mm
④	58 mm
⑤	51 mm
⑥	45 mm
⑦	39 mm
⑧	33 mm
⑨	28 mm
⑩	22 mm
⑪	16 mm

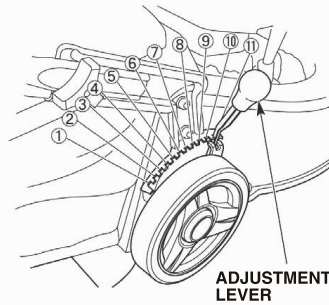

19" Approx. Height

Position	Approx Height
①	80 mm
②	74 mm
③	67 mm
④	60 mm
⑤	54 mm
⑥	47 mm
⑦	41 mm
⑧	35 mm
⑨	29 mm
⑩	22 mm
⑪	16 mm

Shift Lever (HRU216M3 TBUH Only)

The shift lever selects and controls the self-propelled drive speed.

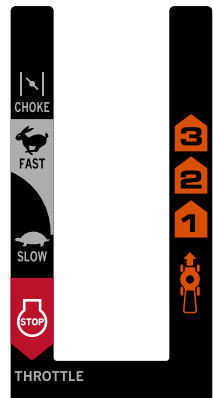
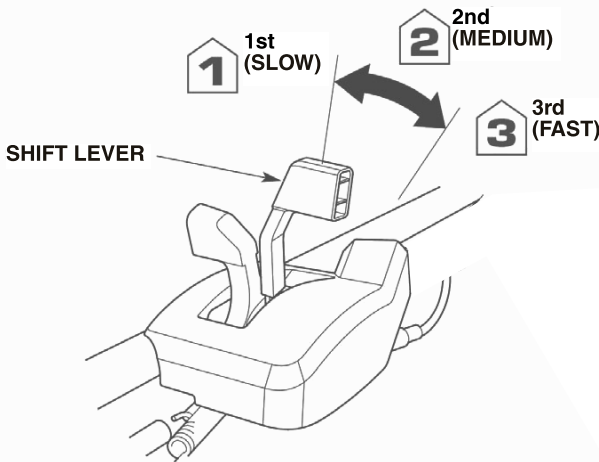

4. CONTROLS

- 1 1st (SLOW)** For mowing thick grass or manoeuvring in small areas.
- 2 2nd (MEDIUM)** For intermediate self-propelled mowing speed.
- 3 3rd (FAST)** For maximum self-propelled transport speed.

Front Guard (HRU216M3 TBUH Only)

Use the front guard when lifting the lawn mower, the front guard can also be utilised to tie down lawnmower for transportation (See page 35).

NOTICE

Do not step on the front guard.

Have the front guard replaced by an authorised Honda service dealer if it becomes bent or damaged.



FRONT GUARD

5. PRE-OPERATION CHECKS

ARE YOU READY TO MOW?

Be sure to wear protective clothing. Long pants and eye protection can lower your risk of injury from thrown objects. Wear footwear that protects your feet and will not let you slip if you mow on slopes or uneven ground.

CHECK YOUR LAWN

For your safety and for the safety of others, always inspect the area before mowing.

OBJECTS

Anything that can be picked up by the blades and thrown is a potential hazard to you and others. Look for things like stones, sticks, bones and wire. Remove them from the mowing area.

NOTICE

Pick up any cord, string or other fibrous material before mowing. These materials can become wrapped around the engine shaft and cause damage to oil seals. Loss of oil can destroy the engine.

PEOPLE & PETS

People and animals near the mowing area can move into your path or into a position where they could be struck by thrown objects. Clear the area of people and pets, especially children. Their safety is your responsibility.

LAWN

Check the length and condition of the grass, so you will know what cutting height and mowing speed to use.

Avoid mowing wet grass. Not only will wet grass clog your cutter housing and collect in clumps on the lawn, it also gives poor traction, increasing your risk of losing your footing.

5. PRE-OPERATION CHECKS

CHECK YOUR MOWER

Blades

Before each use, check the cutter blades for damage or excessive wear.

WARNING

Even though your mower is fitted with either a Blade Brake or Flywheel Brake system, as an added safety precaution to avoid severe personal injury, disconnect the spark plug cap to prevent accidental starting and wear heavy gloves to protect your hands from the cutter blades.

1. Stop the engine and turn the fuel valve to the OFF position.
2. Disconnect the spark plug cap from the spark plug (see page 47).
3. Remove the grass catcher (if installed).
4. Tilt the mower to the right, so the carburettor side is up. This will help to prevent fuel leakage, oil contamination of the air cleaner and hard starting.

GXV160 Engine Type

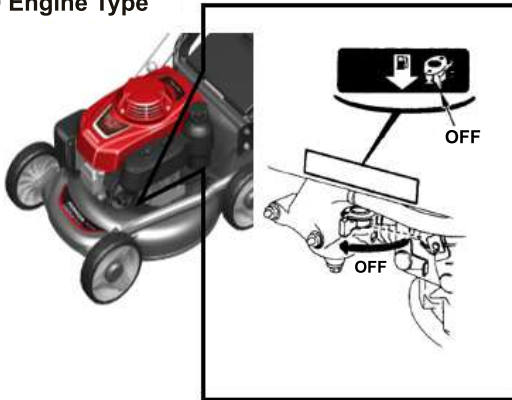

GCV170 Engine Type

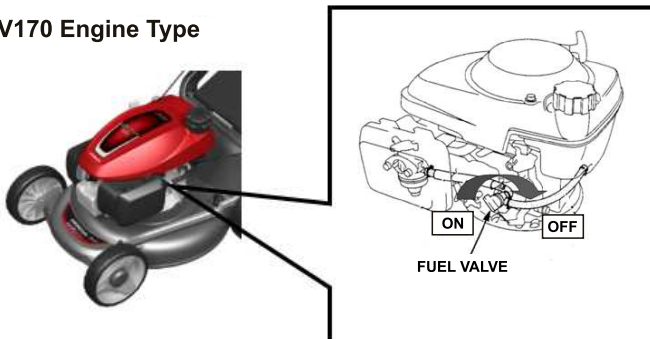

5. PRE-OPERATION CHECKS

5. Inspect the blades for wear and damage.

NOTICE

Always replace the Blades and Setting Bolts at the same time. Worn Bolts may break and cause serious injury.

6. Check that the blade setting bolts and the blade disc holder bolt are tight (see pages 50 ~ 55).

HRU19M2 PKU & HRU196M2 PWUH (Flywheel Brake Type)

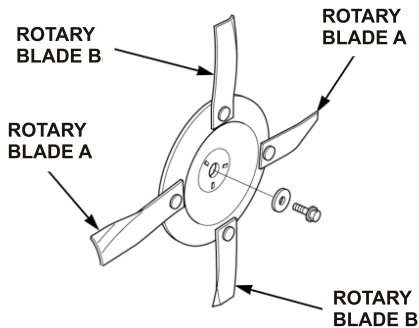

HRU196M2 PBUH & HRU216M3 TBUH

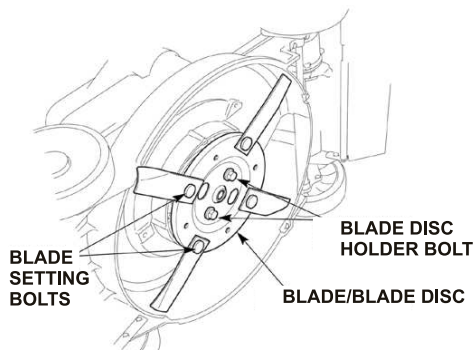

WARNING

Never operate the mower with worn, damaged, split or dented blades. If a piece of blade breaks off and is thrown outwards, it can cause serious bodily injuries.

5. PRE-OPERATION CHECKS

NOTICE

Blade wear will increase when the mower is used on sandy soils. Inspect the blades more often when the mower is used in sandy conditions.

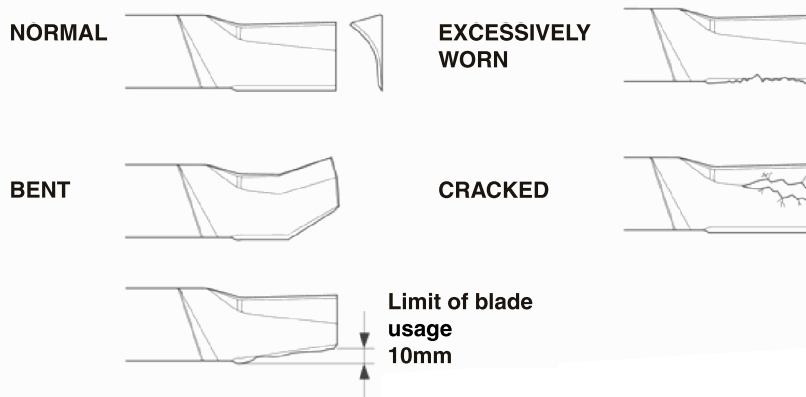

A dull blade can be sharpened, but a blade that is worn out, bent, cracked or otherwise damaged must be replaced. A worn or damaged blade can break, causing blade pieces to be thrown from the mower.

When a blade needs sharpening or replacement, take the lawn mower to an authorised Honda servicing dealer. If you have a torque wrench and the other correct tools, you can remove and install the blades yourself (see page 50~55).

WARNING

If you over sharpen the blades you may cause them to become unbalanced and increase the risk of vibration or blade breakage.

5. PRE-OPERATION CHECKS

Engine Oil Level

Check the engine oil level with the engine stopped and the mower on a level surface.

1. Clean the area around the oil filler cap.
2. Remove the oil filler cap and wipe the dipstick clean.
3. Insert and remove the dipstick without screwing it into the filler neck. Check the oil level shown on the dipstick.
4. If the oil level is low, add the recommended oil (see page 45) to reach the upper limit mark on the dipstick. Do not overfill.
5. After checking the engine oil level, screw in the oil filler cap/dipstick securely.

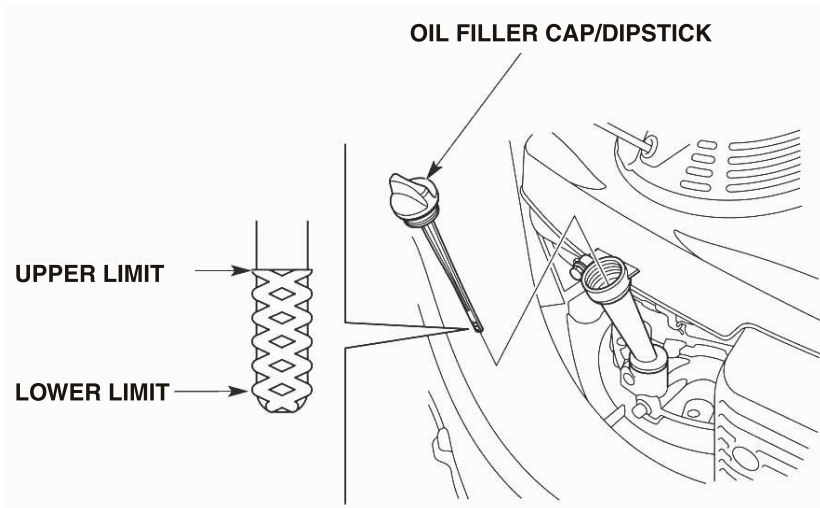

NOTE: OIL FILLER CAP / DIPSTICK MAY VARY IN APPEARANCE, DEPENDING ON THE ENGINE TYPE FITTED TO YOUR MOWER.

5. PRE-OPERATION CHECKS

Fuel

Refuel in a well-ventilated area before starting the engine. If the engine has been running, allow it to cool. See page 49 for fuel recommendations.

Remove the fuel filler cap and check the fuel level. Refill the tank if the fuel level is low. Refuel carefully to avoid spilling fuel. **Do not overfill**; there should be no fuel over the limit mark. After refuelling, tighten the fuel filler cap

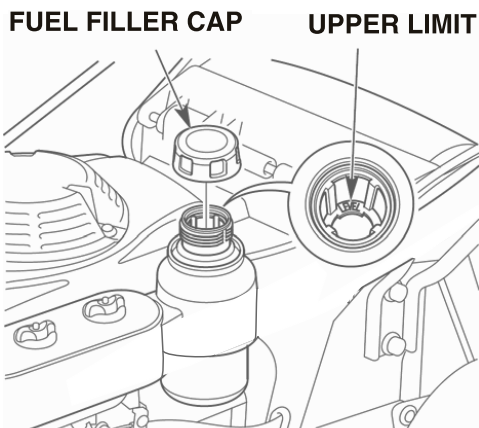

DO NOT OVERFILL FUEL TANK – NOTE “LEVEL” MARK. “LEVEL” MARK MAY VARY DEPENDING ON ENGINE TYPE.

WARNING

Petrol is highly flammable and explosive.

You can be burned or seriously injured when handling fuel.

- **Stop the engine and keep heat, sparks and flame away.**
- **Handle fuel only outdoors.**
- **Wipe up spills immediately.**
- **Wash Hands to remove any fuel residue.**

Do not smoke while refuelling the mower. Never refuel the mower inside a building where petrol fumes may reach flames or sparks. Keep petrol away from appliances with pilot lights, barbecues, electric appliances etc.

NOTICE

Fuel can damage paint and some plastic. Be careful not to spill fuel when filling your fuel tank. Damage caused by spilled fuel is not covered under warranty.

5. PRE-OPERATION CHECKS

Air Cleaner

Inspection

Ensure the air filters are clean and in good condition. A dirty air filter will restrict airflow to the carburettor, reducing engine performance. Refer to page 46 for air cleaner service.

GXV160 Engine Type

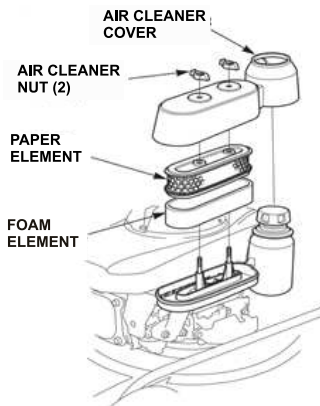

GCV170 Engine Type

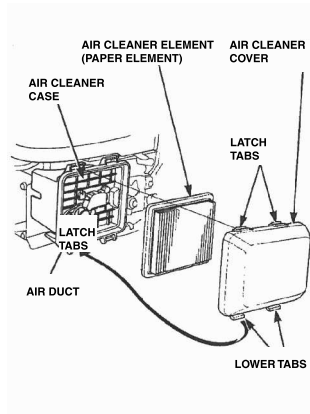

Grass Catcher

A lawn mower works like a vacuum cleaner; it blows air through the catcher, which traps the grass clippings. Always empty the grass catcher before it becomes filled to the limit of its capacity. Catching performance will diminish after the catcher becomes about 90% filled. In addition, the catcher is easier to empty when not packed full.

Inspection

Inspect the grass catcher before use.

Check for holes, cracks and excessive wear.

The grass catcher will wear during normal use and will eventually require replacement (See page 56).

NOTE: Under heavy mowing / grass catching conditions the grass catcher vents may become clogged with dust and dirt. This will affect the catching performance of the catcher. To ensure optimum catching performance, a dirty grass catcher may be washed with water and air dried as necessary.

5. PRE-OPERATION CHECKS

Installation (All 19" Models)

1. Raise the discharge guard and hook the grass catcher onto the cutter housing as shown.
2. Release the discharge guard to secure the catcher in place.

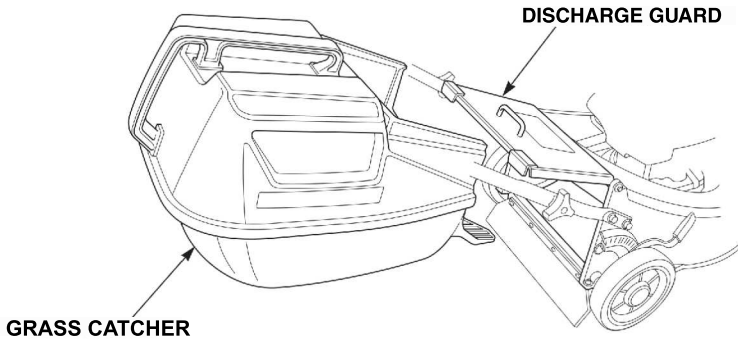

Installation (21" model only)

1. Raise the discharge guard and hook the grass bag frame onto the cutter housing as shown.
2. Release the discharge guard to secure the grass bag in place.

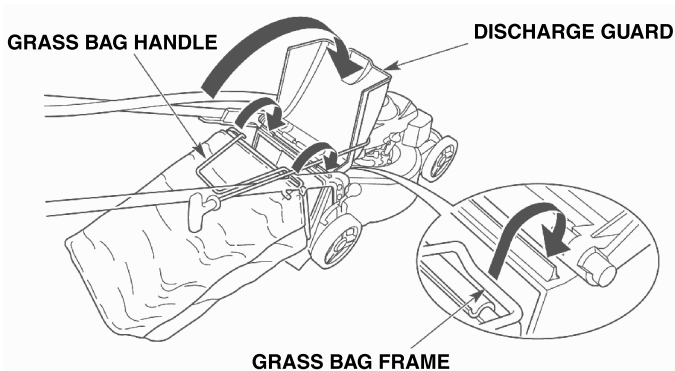

Removal

1. Raise the discharge guard, grasp the catcher handle/ Grass bag frame and remove the grass catcher by lifting slightly and pulling it back towards you.
2. Release the discharge guard.

5. PRE-OPERATION CHECKS

Mulch Plug Installation

Installation (All 19" Models)

1. Raise the discharge guard and insert the mulch plug into the cutter housing as shown.
2. Ensure that the mulch plug is secured firmly onto safety shaft.
3. Release the discharge guard to secure the mulch plug in place.

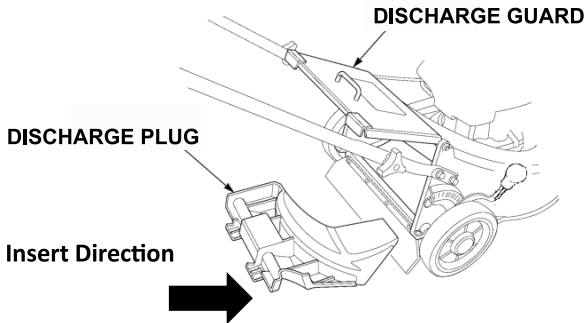

Installation (HRU216M3 TBUH)

1. Raise the discharge guard and insert the mulch plug into the cutter housing as shown.
2. Ensure that the mulch plug has clicked into position to ensure efficient mulching operation.
3. Release the discharge guard to secure the mulch plug in place.

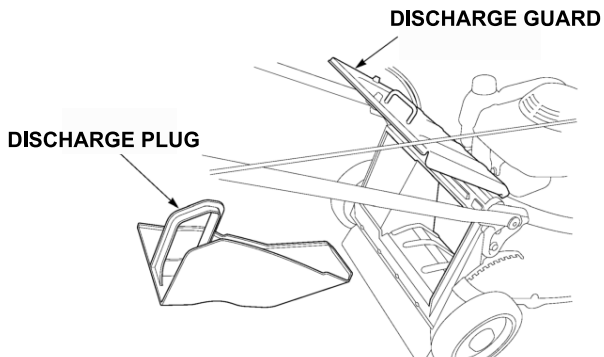

5. PRE-OPERATION CHECKS

Cutting Height

Check the cutter housing height settings. To adjust cutting height, pull the adjustment lever toward the wheel, and move it into another notch. Refer to page 11 for Height Adjustment and Settings.

If you are not sure what cutting height to select, start with a high setting and check the appearance of the lawn after mowing a small area. Then readjust cutting height if necessary.

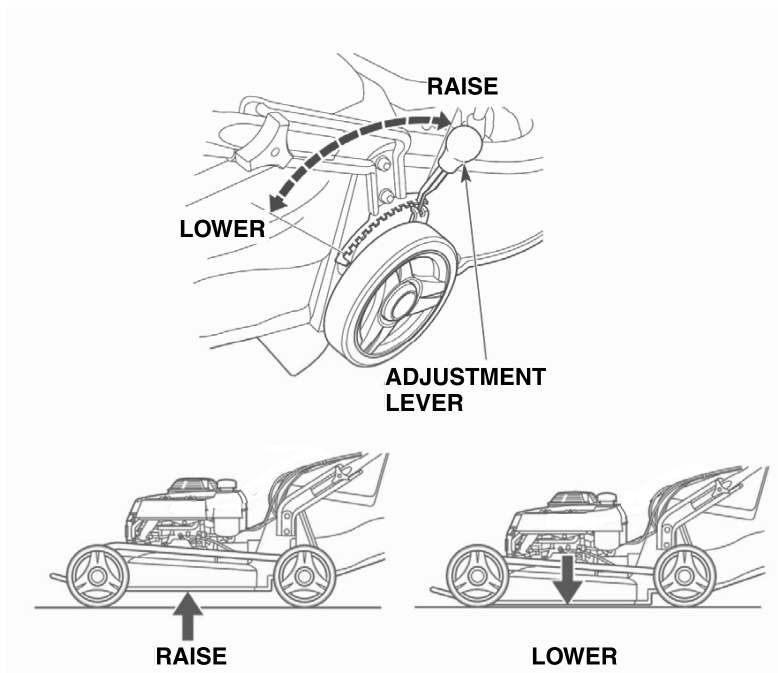

NOTE: Above diagram is for instructional purposes – Actual adjuster may appear slightly different.

MOWING PRECAUTIONS

Before operating the mower for the first time, please review the SAFETY INSTRUCTIONS beginning on page 5 and SAFE MOWING PRACTICES on page 29.

Even if you have operated other mowers, take time to become familiar with how this mower works and practice in a safe area until you build up your skills.

For your safety, avoid starting or operating the engine in an enclosed area such as a garage. Your mower's exhaust contains poisonous carbon monoxide gas, which can collect rapidly in an enclosed area and cause illness or death.

STARTING THE ENGINE

1. Turn the fuel valve to the ON position.

GXV160 Engine Type

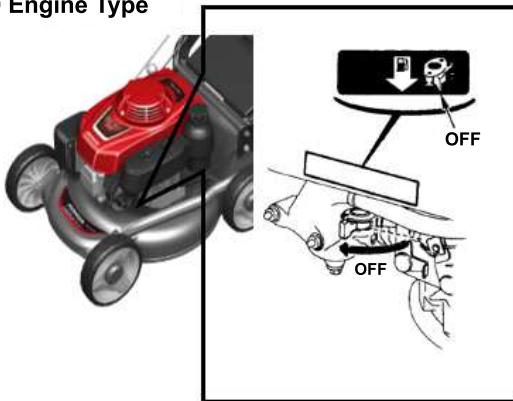

GCV170 Engine Type

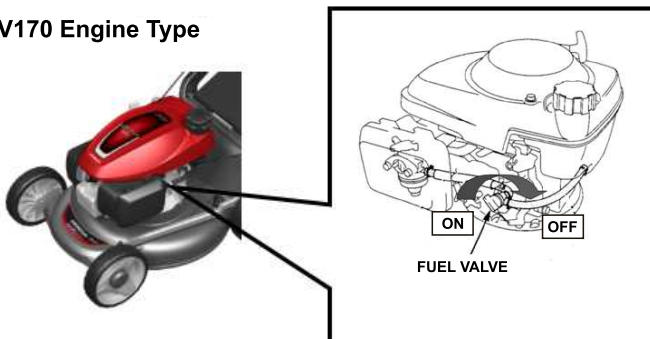

6. OPERATION

For All models except HRU19M2 PKU (for HRU19M2 PKU starting, proceed to step 3)

2. Move the throttle lever to the proper starting position

COLD ENGINE:

Move the throttle lever to the **CHOKE** position

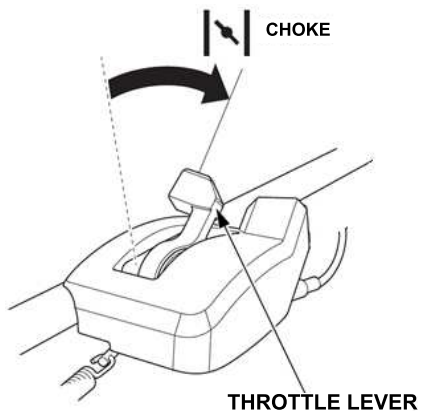

WARM ENGINE:

Move the throttle lever to the **HIGH** position.

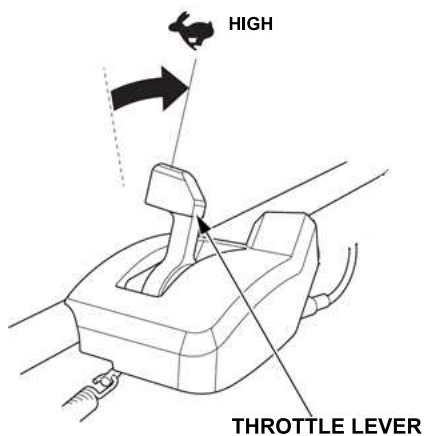

- Engage the flywheel brake control lever to release the engine brake (HRU19M2 PKU & HRU196M2 PWUH Only)

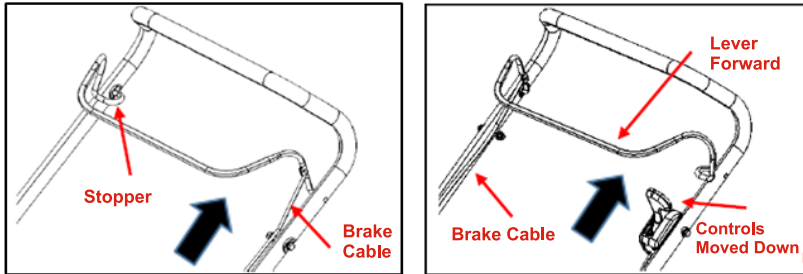

Engagement Direction



- Pull the starter grip lightly until you feel resistance, then pull briskly in the direction of the arrow as shown below. To avoid possible damage, return the starter grip gently, do not just release it and let it go on its own. Keep your hands and feet away from the cutter housing at all times when starting and running the engine.



6. OPERATION

5. If the CHOKE position was used during starting, move the throttle lever away from the CHOKE position as soon as the engine warms up enough to run smoothly. Set the throttle lever at HIGH to mow or at LOW to idle.

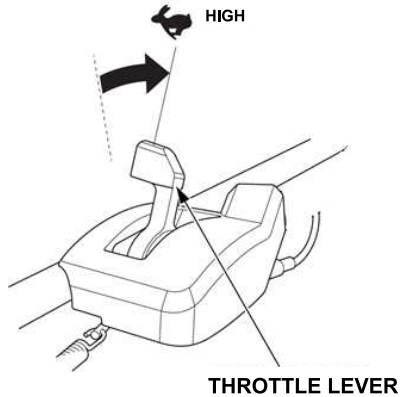

OPERATING THE CONTROLS FOR MOWING

Throttle Lever

For best cut quality, always mow with the throttle lever in the HIGH position. When the blades rotate at the pre-set fast speed, it creates a strong fan action that lifts and cuts grass more efficiently. Do not try to increase the pre-set engine speed, the blades could fracture and come apart and engine life will be shortened.

When you need to leave the mower for any reason, your mower is equipped with a Flywheel Brake/Blade Brake, and the Engine or Blade will stop when you release the lever.

Blade Control Lever (HRU196M2PBUH & HRU216M3 TBUH)

BLADE CONTROL LEVER

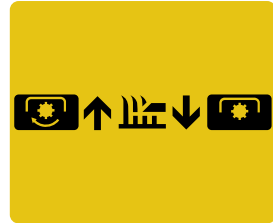
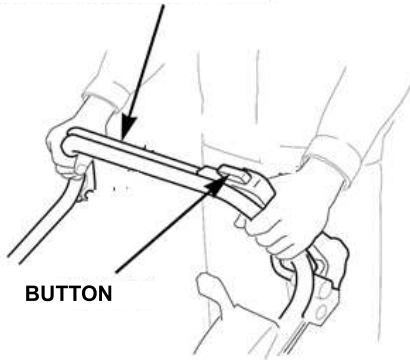

To start blade rotation, press the yellow button on top of the blade control lever, then push the lever forward quickly and hold it against the handlebar. To prevent stalling, always put the throttle lever in the fast position before engaging the blade control lever.

Release the blade control lever to stop the blades.

Operate the blade control lever with a quick and complete motion, so the blade control is always either fully engaged or stopped. This will help to prevent stalling the engine, and will extend the service life of the blade control mechanism.

Always release the blade control lever before starting the engine to prevent the blades from turning.

6. OPERATION

TO STOP THE ENGINE (FWB Models HRU19M2 PKU & HRU196M2 PWUH)

1. Release the Flywheel Brake control lever and the engine will STOP automatically.
2. When the mower is not in use, return the Throttle Lever to the SLOW position and turn the fuel valve to the OFF position as shown on (Page 14).

TO STOP THE ENGINE (BBC Models HRU196M2 PBUH & HRU216M3 TBUH)

1. Release the Blade Brake clutch control lever. This will disengage the blades.
2. Move the throttle lever to the STOP position.

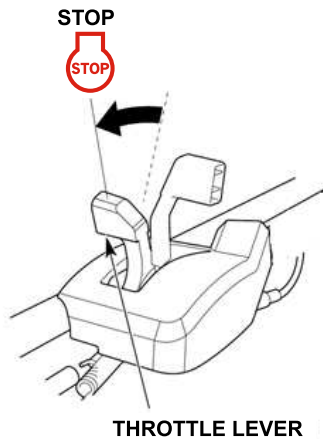

3. When the mower is not in use, turn the fuel valve to the OFF position as shown on (Page 14).

SAFE MOWING PRACTICES

For your safety, keep all four wheels on the ground and be careful to avoid losing your footing and your control of the mower. Keep a firm grip on the handlebar and walk, never run with the mower. Be very careful when mowing uneven or rough ground. Never mow while walking backwards.

If stuck, do not kick or shove the mower with your foot. Use the handlebar to control mower.

WARNING

The blades are sharp and spin at high speed.

A spinning blade can cut you severely and can amputate fingers and toes.

- Wear protective footwear.
- Keep your hands and feet away from the cutter housing while the engine is running.
- Stop the engine before performing any adjustment, inspection or maintenance.

Slopes

Mow across slopes, not up and down. Avoid steep slopes (more than 20°), and be careful when changing direction. Mowing on a slope when the grass is damp or wet could cause you to slip, fall and lose control of the mower.

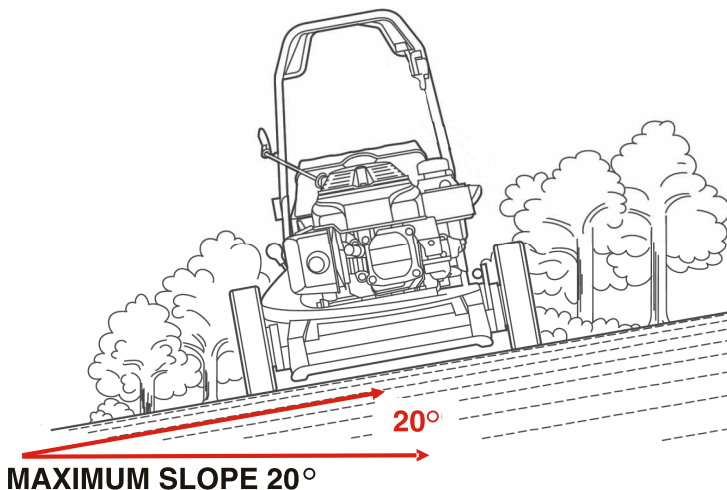

6. OPERATION

Obstacles

Use the side of the mower to cut close to large obstacles, such as fences or walls. Push the mower slowly around obstacles for better directional control. Be careful when mowing over obstacles embedded in the lawn, such as sprinkler heads, paving and edging etc. Avoid anything that sticks up above the surface of the lawn.

If a blade hits something, or if the mower starts to vibrate, stop the engine immediately, disconnect the spark plug cap and check blades for damage (see pages 14 & 15). Striking objects may damage the blades, bend the crankshaft, and/or break the cutter housing or other components. Vibration usually indicates damage to the mower or debris caught in the blades.

WARNING

A worn, cracked, or damaged blade can break, and pieces of the damaged blade can become dangerous projectiles.

Thrown objects can cause serious injury.

Inspect the blades regularly, and do not operate the mower with a worn or damaged blade.

The Warranty does not cover parts damaged by accident or collision.

Gravel and Loose Objects

Gravel, loose stones and landscaping material may be picked up by the mower and thrown outwards with enough force to cause serious personal injury and/or property damage. The best way to prevent potential injury from thrown objects is to release the blade control lever to stop the blades before reaching areas with gravel, loose stones or landscaping material.

MOWING TIPS

Cutting Height

Consult a local nursery or lawn and garden centre for cutting height recommendations and advice about specific types of grasses and growing conditions in your area.

If you look closely, you will see that most grass has stems and leaves. If you cut off the leaves, you will scalp the lawn. Let the grass recover between mowing. Your mower will work better and your lawn will look better.

If your grass gets too tall, cut it once at the highest cutting height setting then mow again in 2 or 3 days. Do not take off more than one third of total grass height in any one mowing, or brown patches may develop.

Cutting height adjustment is explained on page 11.

Cutting Width

For an even lawn finish, overlap each mowing swath by approximate 10cm. If the grass is very tall or thick, use more overlap and a narrower mowing swath.

Blade Speed

The blades must spin very fast to cut properly. Always use the HIGH throttle setting and keep the engine running at maximum speed setting. If the engine speed drops, it could mean the engine is being overloaded by the blades trying to cut too much grass. Mow a narrower swath, move the mower slower, or raise the cutting height.

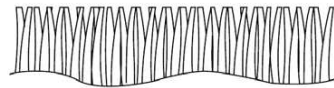

LONG ENOUGH



TOO SHORT

6. OPERATION

Blade Sharpness

A sharp blade cuts cleanly. A dull blade tears the grass, leaving shredded ends that turn brown. When your blades do not cut cleanly anymore, have them sharpened or replaced by a suitably qualified technician.

Dry Grass

If the ground is too dry, mowing will stir up a lot of dust. Besides being unpleasant to work in, too much dust will clog the air filter. If dust is a problem, water your lawn the day before mowing. Mow when the grass is dry to your touch, but the soil is still moist.

TIP: Consider wearing a P2 Dust mask when mowing.

Wet Grass

Wet grass is slippery and can make you lose your footing and wet grass clippings will clog the cutter housing and collect in clumps on the lawn. Always wait for wet grass to dry before mowing.

Fallen Leaves

When equipped with the grass catcher, your mower can be used to pick up fallen leaves for disposal. If using the mower to catch large amounts of fallen leaves, and not for mowing, set the cutting height adjustment lever at highest setting.

If you want to mulch fallen leaves into your lawn, do not let the leaf cover get too deep before you begin. For best results, start mulching while grass still shows through the leaf cover. In places where fallen leaves completely cover the grass remove the leaves by raking, or install a grass catcher, so your mower can pick them up for disposal.

Clogged Cutter Housing

If the cutter housing becomes clogged, before attempting to clear it, stop the engine and turn the fuel valve to the OFF position (page 8). With the spark plug cap disconnected (page 47), tilt the mower to the right hand side so the carburettor is facing up.

NOTE: Clear any blockage with a stick, not by your hands.

Mowing Patterns

Your Honda mower will work most efficiently if you use the following mowing patterns as much as possible. Cutter housing, equipment design and the direction in which the blades rotate, ensures that these mowing patterns will give the best results.

Bagging

Use a clockwise mowing pattern. This will give the best catching performance, leaving the least amount of clippings on the lawn.

NOTE: If your mower is fitted with a Mulching Plug, mowing in a Counter Clockwise direction will give the best result.

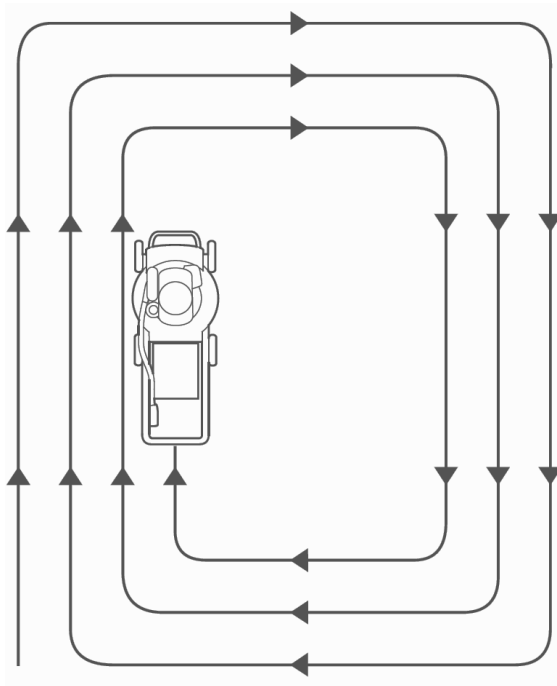

7. TRANSPORTING/STORAGE

BEFORE LOADING

If the engine has been running, allow it to cool for at least 15 minutes before loading the mower on to the transport vehicle. A hot engine and exhaust system can burn you and can ignite some materials.

Turn the fuel valve to the OFF position. This will prevent carburettor flooding and reduce the possibility of fuel leakage.

GXV160 Engine Type

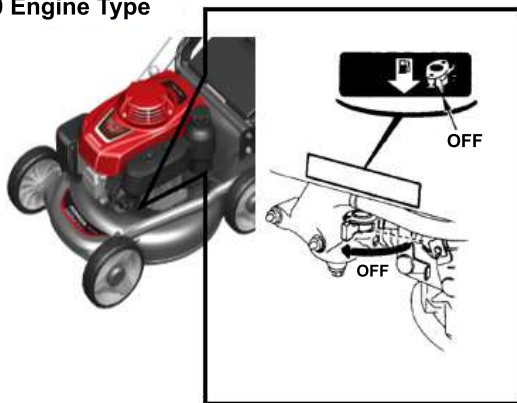

GCV170 Engine Type

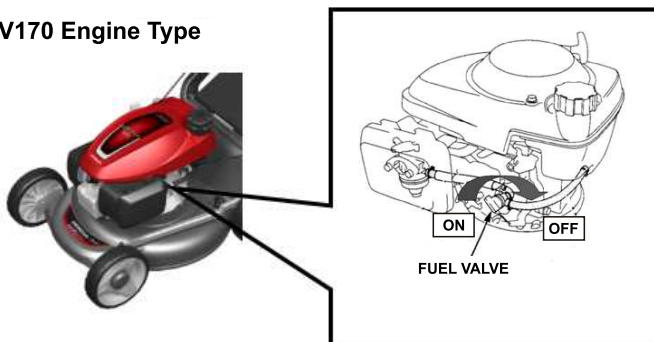

If equipped, remove the grass catcher.

7. TRANSPORTING/STORAGE

LOADING AND UNLOADING

If a suitable loading ramp is not available, two people should lift the mower on and off the transport vehicle while holding the mower level.

Position the mower so all four wheels are on the bed of the transport vehicle. Tie the mower down with rope or straps, using the Front Guard as a tie down point, and chock the wheels. Keep the tie-down rope or straps away from the controls, adjustment levers, cables and the carburettor.

The handlebar can be folded so the mower will take up less space (see page 39).

STORAGE PREPARATION

Proper storage preparation is essential for keeping your lawn mower trouble-free and looking good. The following steps will help to keep rust and corrosion from impairing your lawn mowers function and appearance and will make the engine easier to start when you use the lawn mower again.

7. TRANSPORTING/STORAGE

Cleaning

Wash your mower after use, including the underside of the cutter housing.

Wash the engine by hand and be careful to prevent water from entering the air cleaner and/or muffler.

NOTE: Using a garden hose or pressure washing equipment can force water into the air cleaner, which will soak the filters and can enter the carburettor or engine, causing damage.

Cold water on a hot engine can cause damage. If the engine has been running, allow it to cool for at least 30 minutes before washing.

Cutter Housing

If using a garden hose or pressure washing equipment to clean the upper side of the cutter housing, be careful to avoid getting water into controls and cables or anywhere near the engine air cleaner or muffler opening.

To wash the underside of the cutter deck, attach a garden hose to the fitting on the cutter deck (see below) and turn water on. Start engine, engage blades, and allow it to run at normal operating speed for several minutes. This should be done in an area where the water and debris can run onto grass or a dirt surface.

Do not flush the water or debris into the storm water system.



**GARDEN HOSE
CONNECTED
TO WASH FEATURE**

1. After washing the lawn mower, remove garden hose and wipe dry all accessible surfaces.
2. With the mower in an upright position, start the engine outdoors and let it run until it reaches normal operating temperature to evaporate any water remaining on the engine.
3. Stop the engine and allow it to cool.
4. After the lawn mower is clean and dry, coat areas that may rust with a light film of oil or Silicon Spray. Also, lubricate the control cable cores with a silicon spray lubricant.

7. TRANSPORTING/STORAGE

Fuel

Petrol will oxidize and deteriorate over time when stored. Old petrol will cause hard starting and it leaves gum deposits that clog the fuel system. If the petrol in your mower deteriorates during storage, you may need to have the carburettor and other fuel system components serviced or replaced.

The length of time that petrol can be left in your fuel tank and carburettor without causing functional problems will vary with such factors as petrol blend your storage temperatures and whether the fuel tank is partially, or completely filled. The air in a partially filled fuel tank promotes fuel deterioration. Very warm or humid storage temperatures will accelerate fuel deterioration.

Fuel deterioration problems may occur within 30 days, or even less, if the petrol was not fresh when you filled the fuel tank.

NOTE: Your Honda mower can operate on blended fuel containing a maximum of 10% Ethanol. However, fuel containing Ethanol will deteriorate quicker than non-blended fuel.

The Warranty does not cover fuel system damage or engine performance problems resulting from the use of blended fuels or neglected storage preparation.

You can avoid fuel deterioration problems by draining the fuel tank and carburettor.

NOTICE

USE GENUINE HONDA FUEL STABILISER TO PROLONG THE LIFE OF YOUR MOWER FUEL.

Petrol spoils very quickly depending on factors such as light exposure, temperature and time.

In worst cases, petrol can become stale within 30 days.

Using stale or contaminated fuel can seriously damage the engine (carburettor clogged, sticking valves).

Such damage due to spoiled fuel is not warrantable.

To avoid this please strictly follow these recommendation:

- Only use specified fuel (see page 49).
- Only use fresh and clean fuel of appropriate Octane Rating.
- To slow down deterioration, keep fuel in a certified fuel container.
- If the mower is to be stored for more than 30 days, drain fuel tank and carburettor (see page 38).

7. TRANSPORTING/STORAGE

Draining the Fuel Tank and Carburettor

1. Empty the fuel tank into an approved petrol container.
2. Remove the carburettor drain bolt with a 10mm wrench and drain the carburettor bowl fuel into an approved container.

WARNING

Petrol is highly flammable and explosive.

You can be burned or seriously injured when handling fuel.

- **Stop the engine and keep heat, sparks and flame away.**
- **Handle fuel only outdoors.**
- **Wipe up spills immediately.**
- **Wash Hands to remove Fuel residue.**

3. Turn the fuel valve to the ON position (see page 14). This will allow fuel in the fuel tank to drain through the carburettor bowl. After the fuel is completely drained, reinstall the sealing washer and the drain bolt.

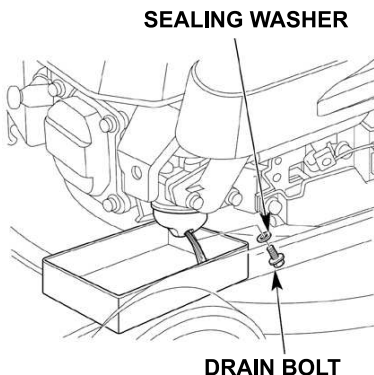

Engine Oil

Change the engine oil (see page 44).

Engine Cylinder

1. Remove the spark plug (see page 47).
2. Pour 5-10cc (One Teaspoon) of clean engine oil into the cylinder.
3. Pull the starter grip several times to distribute the oil in the cylinder.
Reinstall the spark plug.
4. Pull the starter grip slowly until resistance is felt, then return the starter grip gently. This closes the valves so moisture cannot enter.

7. TRANSPORTING/STORAGE

Handlebar Folding

1. Remove the grass Catcher, if installed.
2. Loosen or remove the two Handle Joint Grips.

NOTE: IF you remove the bolts, take care not to lose the Spacer washers.

3. Pull the handlebar struts to release them from the locating grooves then swing the handlebar forward with the drive clutch lever held by your hand. Take care not to allow the cables to be bent or pinched.
4. Firmly install the two Handle Joint Grips.

HRU19M2 PKU
Shown



**FOLDED UNIT
READY FOR
STORAGE**

Handlebar Setting

Squeeze the Flywheel Brake lever and raise the handlebar in place in the reverse order of handlebar folding, taking care that the cables are not pinched.

7. TRANSPORTING/STORAGE

STORAGE PRECAUTIONS

If your mower will be stored with petrol in the fuel tank and carburettor, it is important to reduce the hazard of petrol vapour ignition. Select a well-ventilated storage area away from any appliance that operates with a flame, such as a furnace or water heater. Also, avoid any area with a spark-producing electric motor, or where power tools are operated.

If possible, avoid storage areas with high humidity as humidity promotes rust and corrosion.

Unless all fuel has been drained from the fuel tank, turn the fuel valve to the OFF position to reduce the possibility of fuel leakage.

Place the mower with its wheels on a level surface. Tilting can cause fuel or oil leakage.

The handlebar can be folded for compact storage (see page 39).

With the engine and exhaust system cool, cover the mower to keep out dust. A hot engine and exhaust system can ignite or melt some materials. Do not use plastic sheet as a dust cover. A nonporous cover will trap moisture around the mower, promoting rust and corrosion.

A liberal coating of Silicon spray or similar, over the entire mower, will help to prevent any corrosion or “freezing up” of any moveable components during storage. Wipe off any excess before starting the mower.

NOTE: When the mower is started some smoking may occur as the mower warms up, this is normal.

If the cylinder was coated with oil during the storage preparation, the engine will smoke briefly at start-up. This is also normal.

THE IMPORTANCE OF MAINTENANCE

Good maintenance is essential for safe, economical and trouble-free operation. It will also help reduce air pollution.

WARNING

To avoid the mower starting accidentally, pull off the spark plug cap before carrying out maintenance work.

Improper maintenance or failure to correct a problem before operation can cause a malfunction in which you can be seriously hurt or killed.

Always follow the inspection and maintenance recommendations and schedules in this owner's manual.

To help you properly care for your mower, the following pages include a maintenance schedule, routine inspection procedures and simple maintenance procedures using basic hand tools.

Other service tasks that are more difficult, or require special tools, are best handled by professionals and are normally performed by a Honda technician or other qualified mechanic. The maintenance schedule applies to normal operating conditions. If you operate your mower under severe conditions, such as sustained high-load conditions, consult your servicing dealer for recommendations applicable to your individual needs and use.

8. MAINTENANCE

MAINTENANCE SAFETY

Some of the most important safety precautions follow. However, we cannot warn you of every conceivable hazard that can arise in performing maintenance. Only you can decide whether you are capable of performing a given task.



Failure to follow maintenance instructions and precautions properly can cause you to be seriously hurt or killed.

Always follow the procedures and precautions in this owner's manual.

Safety Precautions

- Make sure the engine is off before you begin any maintenance or repairs. This will eliminate several potential hazards:
 - Carbon monoxide poisoning from engine exhaust.**
Be sure there is adequate ventilation whenever you operate the engine.
 - Burns from hot parts.**
Let the engine and exhaust system cool before touching.
 - Injury from moving parts.**
Do not run the engine unless instructed to do so.
- Read and understand the instructions before you begin and make sure you have the tools and skills required.
- To reduce the possibility of fire or explosion, be careful when working around petrol. Do not use petrol to clean parts, use only a non-flammable solvent. Keep cigarettes, sparks and flames away from all fuel-related parts.

Remember that an authorised Honda servicing dealer knows your mower best and is fully equipped to maintain and repair it.

To ensure the best quality and reliability, use only new, Honda genuine parts and lubricants for repair and/or replacement.

MAINTENANCE SCHEDULE

◇ GCV170 engine models only
o GXV160 engine models only

Inspection item	Inspection Time						
	Each use month or 5 Hrs.	First month or 20 Hrs.	Every 3 months or 50 Hrs.	Every 6 months or 100 Hrs.	Every 6 months or 150 Hrs.	Every year or 200 Hrs.	Every year or 300 Hrs.
Engine Oil	◇ o						
Change	◇	o	◇ 4	o			
Air Cleaner	◇ 2o2						
Clean or replace			◇ 2o2				
Blade Bolts, Blades & Washers	◇ o					◇ o	
Check and replace if necessary							
Spark Plug				◇ o			
Check, Clean & Adjust							
Throttle and Roto-Stop Cables				◇ 3o3			
Check and Adjust				◇ 3			o3
Valve Clearance							
Check and Adjust					◇ 3		o3
Idle Speed							
Check and Adjust					◇ 3o3		
Plywheel brake pad (Zone models)							
Check							
Rear Shield	◇ o						
Check							
Grass Catcher	◇ o						
Check							
Blade Control Operation	◇ o						
Check							
Fuel Tank and Filter				◇ 3			o3
Clean							
Fuel Hose							
Check and replace if necessary							
							◇ o every 2 years ³

NOTE: Combustion chamber cleaning is necessary for GCV170 (◇) and GXV160 (o) at 300 hours.

1. For commercial use, log hours of operation to determine proper maintenance intervals.
2. Service more frequently when used in dusty conditions.
3. These items should be serviced by an Authorized Honda Dealer.
4. Change engine oil every 25 hours when used under heavy load or in high ambient temperature.

8. MAINTENANCE

ENGINE MAINTENANCE

Engine Oil Change

Drain the used oil while the engine is warm. Warm oil drains quickly and completely.

1. Turn the fuel valve to the OFF position to reduce the possibility of fuel leakage.
2. Wipe the oil filler area clean, and then remove the oil filler cap/dipstick.
3. Place a suitable container next to the mower to catch the used oil, and then tilt the mower on its right side. The used oil will drain through the filler neck. Allow the oil to drain completely.

NOTE: Do not throw waste oil or containers in the trash or pour oil on the ground or down a drain. We suggest you take it in a sealed container to your local recycling centre or service station for reclamation.

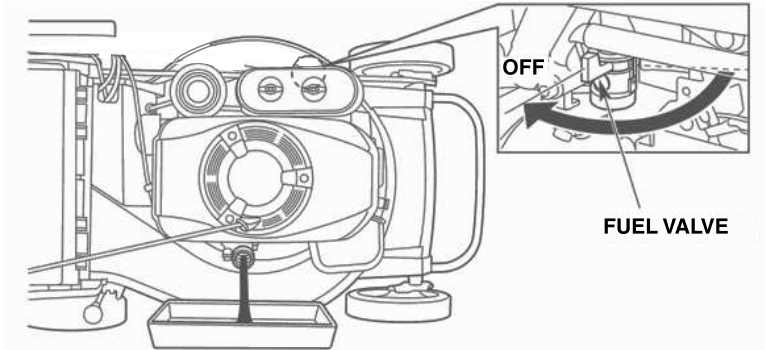

4. Fill with the recommended oil. Do not overfill; measure the oil level as shown on page 17.

Engine oil capacity: 0.65 Litre - HRU196/216
0.40 Litre - HRU19

NOTICE

Using non-detergent oil can shorten the engine's service life and using 2-stroke engine oil will damage the engine.

5. After changing the engine oil and before starting the engine, check the oil level with the mower on a level surface:
 - a) Wipe the dipstick clean.
 - b) Insert and remove the dipstick without screwing it into the filler neck. Check the oil level shown on the dipstick.
 - c) If the oil level is low, add oil to reach the upper limit mark on the dipstick. Do not overfill. If the engine is overfilled, the excess oil may be transferred to the air cleaner housing and air filter.

NOTICE

Running the engine with a low oil level can cause severe engine damage.

- d) Screw the oil filler cap/dipstick back in securely

Engine Oil Recommendations

Oil is a major factor affecting performance and service life.

Use 4-stroke motor oil that meets or exceeds the requirements for API service classification SG or higher (or equivalent). Always check the API service label on the oil container to be sure it includes the letters SG or higher (or equivalent).

SAE 10W-30 is recommended for general use in Australia.

Contact your local Honda Power Equipment Dealer for Honda Genuine Oils.

OIL FILLER CAP/DIPSTICK

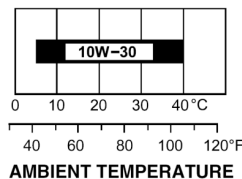
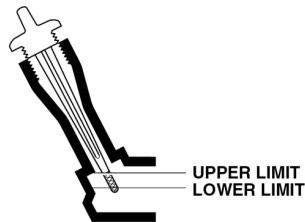
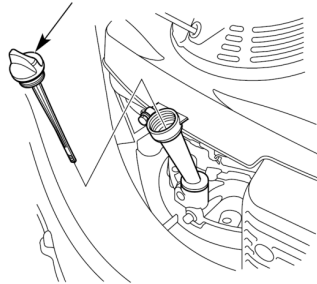

8. MAINTENANCE

Air Cleaner Service

A dirty air cleaner will restrict airflow to the carburettor, reducing engine performance. If you operate the mower in very dusty areas, clean the air cleaner more often than specified in the MAINTENANCE SCHEDULE.

NOTICE

Operating the engine without an air filter or with damaged filters, will allow dirt to enter the engine, causing rapid engine wear. This type of damage is not covered by Warranty.

1. Unscrew and remove the two air cleaner nuts, then remove the air cleaner cover.
2. Remove the filter elements from the air cleaner housing and remove the foam filter element from the paper filter element.
3. Inspect the filter elements for holes or tears and replace them if damaged.

GXV160 Engine Type

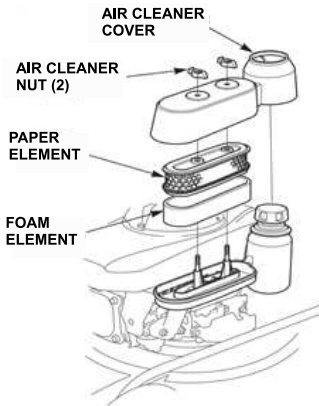

GCV170 Engine Type

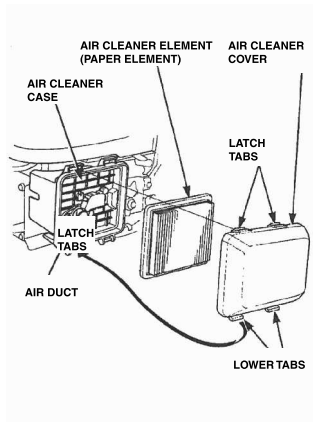

4. Clean the filter elements.

Paper filter element: Tap the filter several times on a hard surface to remove dirt, or blow compressed air (not exceeding 207kPa) through the filter from the inside. Never try to brush off dirt; brushing will force dirt into the fibres.

Foam element: Clean in warm soapy water, rinse and allow it to dry thoroughly, or clean in non-flammable solvent and allow it to dry. Dip the filter element in clean engine oil, and then squeeze out excess oil.

5. Wipe dirt from the inside of the air cleaner housing and cover, using a moist rag. Be careful to prevent dirt from entering the air duct that leads to the carburettor.
6. Reinstall the filters and cover and (where used) tighten the air cleaner nuts securely.

Spark Plug Service

Recommended spark plug:

GXV160 & GCV170 BPR5ES (NGK) or W16EPR-U (DENSO)

NOTICE

An incorrect spark plug can cause engine damage.

For good performance, the spark plug must be properly gapped and free of deposits.

1. Disconnect the spark plug cap and remove the dirt from around the spark plug, to avoid it entering the engine when the plug is removed.

SPARK PLUG CAP

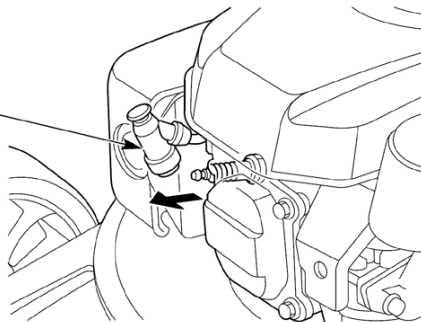

8. MAINTENANCE

2. Use the correct spark plug wrench to remove the spark plug.
3. Inspect the plug; replace it if the electrode is worn, or if the insulator is cracked or chipped.
4. If you are going to reuse the spark plug, remove carbon deposits with a stiff wire brush.
5. Measure the spark plug gap with a suitable gauge. The gap should be 0.7-0.8mm. Correct the gap, if necessary by bending the side electrode.

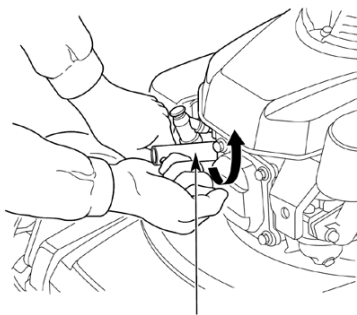

SPARK PLUG WRENCH

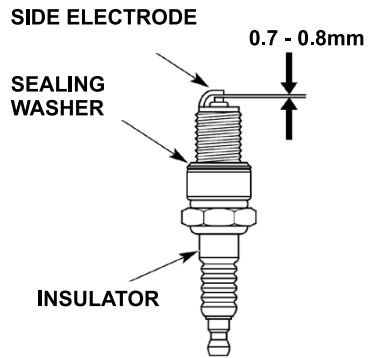

6. Install the spark plug carefully by hand, to avoid cross threading.
7. After the spark plug seats, tighten with a spark plug wrench to compress the washer.
If reinstalling the old spark plug, tighten $\frac{1}{8}$ to $\frac{1}{4}$ turn after the spark plug seats.
If installing a new spark plug, tighten $\frac{1}{2}$ turn after the spark plug seats.

NOTICE

- A loose spark plug can overheat and damage the engine.
 - Over tightening the spark plug can damage the threads in the cylinder head.
8. Install the spark plug cap on the spark plug.

Carburettor Modification for High Altitude Operation

At high altitude, the standard air-fuel mixture will be too rich. Performance will decrease and fuel consumption will increase. A very rich mixture will also foul the spark plug and cause hard starting.

High altitude performance may be improved by specific modifications to the carburettor. If you always operate your lawn mower at altitude above 1,500 metres, have your servicing dealer perform carburettor modifications.

Even with carburettor modification, engine horsepower will decrease about 3.5% for each 300 metres increase in altitude. The effect of altitude on horsepower will be greater than this if no carburettor modifications are made.

NOTICE

When the carburettor has been modified for high altitude operation, the air-fuel mixture will be too lean for low altitude use. Operation at altitude below 1,500m with modified carburettor may cause the engine to overheat and result in serious engine damage. For use at low altitude, have your servicing dealer return the carburettor to original factory specifications.

Fuel Recommendations

This engine is certified to operate on unleaded petrol with a pump octane rating of 91 or higher. Unleaded petrol produces fewer engine and spark plug deposits and extends exhaust system life. Never use stale or contaminated petrol or an oil/petrol mixture. Avoid getting dirt or water in the fuel tank. Occasionally you may hear light “spark knock” or “pinging” (metallic rapping noise) while operating under heavy loads. This is no cause for concern. If spark knock or pinging occurs at a steady engine speed, under normal load, change brands of petrol. If spark knock or pinging persists, see an authorised Honda servicing dealer.

NOTICE

Running the engine with persistent spark knock or pinging can cause engine damage. Running the engine with persistent spark knock or pinging is misuse and the Warranty does not cover parts damaged by misuse. **For Ethanol blended or oxygenated fuel information, Refer to page 37.**

8. MAINTENANCE

BLADE REMOVAL AND INSTALLATION

If you have removed the blade assembly, always use a torque wrench to reinstall. Wear heavy gloves to protect your hands. To avoid weakening the blades or causing imbalance or poor cutting, the blades should only be sharpened by trained staff at an authorised Honda servicing dealer. If you are replacing the blades, use Honda genuine replacement blades and setting bolts or equivalent. Always replace the blades and setting bolts as a set.

Removal:

1. Turn the fuel valve to the OFF position.
2. Disconnect the spark plug cap, and tilt the mower to the right side, so the carburettor side is facing up.
3. Hold the blade disc firmly by inserting a suitable screwdriver through the blade disc to prevent it from turning when removing the blade disc holder bolt.

GXV160 Engine Type

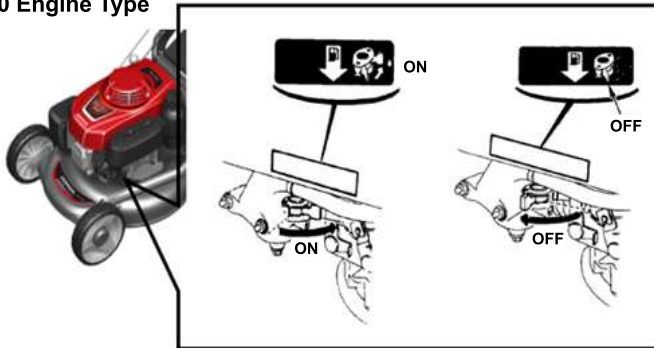

GCV170 Engine Type

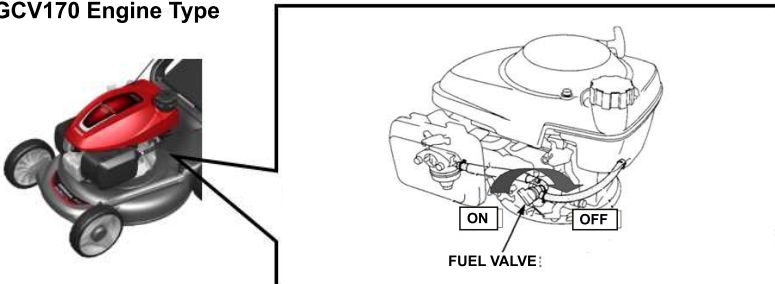

8. MAINTENANCE

1. Diagram 1.1. Below shows the order of assembly for Thrust Washer, Woodruff Key, Blade Holder, blade/blade disc, washers and blade disc holder bolt removed.
(Specific to HRU19M2 PKU & HRU196M2 PWUH models only)

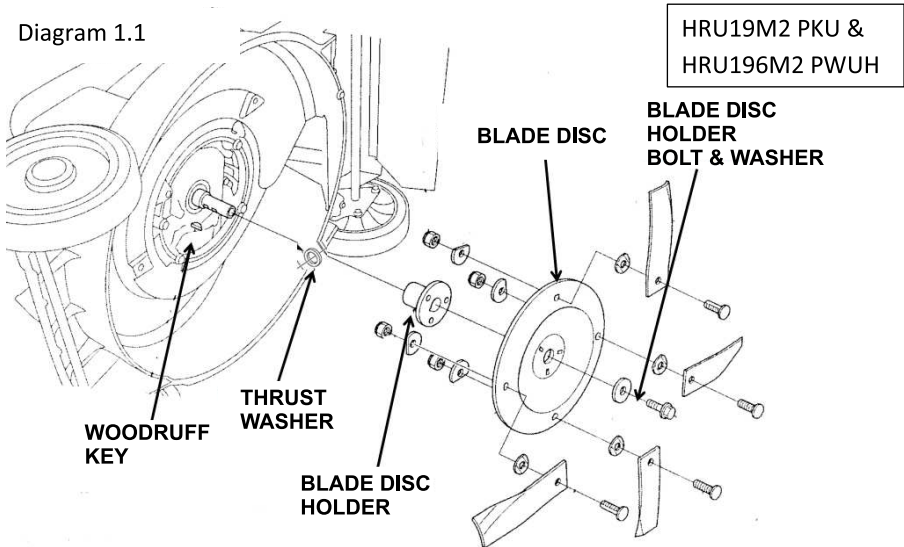
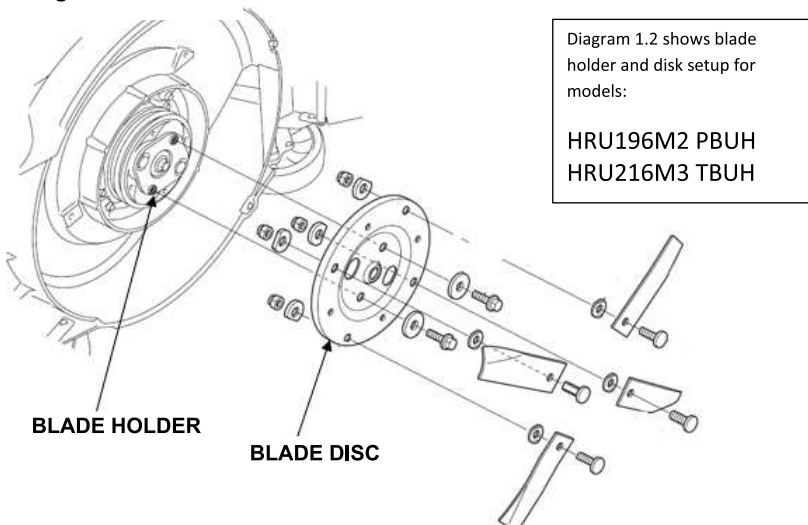
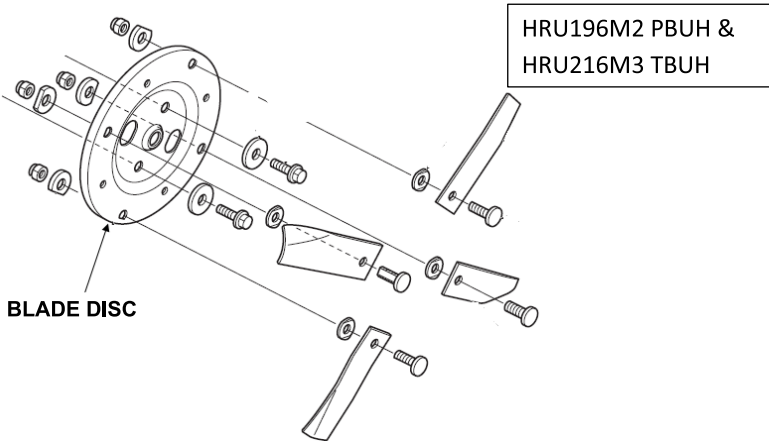
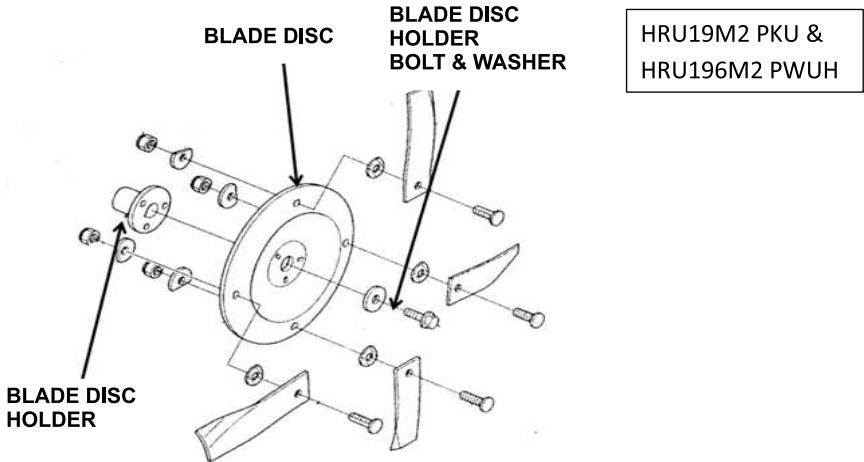

Diagram 1.2



8. MAINTENANCE

2. Remove the blade setting bolts, blades, spring washers, blade washers and self-lock nuts from the blade disc.



Installation:

1. Clean dirt and grass from the blades, blade disc and the inside on the cutter housing.
2. Install the blade, spring washers, blade washers and self-lock nuts to the blade disc using the new blade setting bolt set as described below.

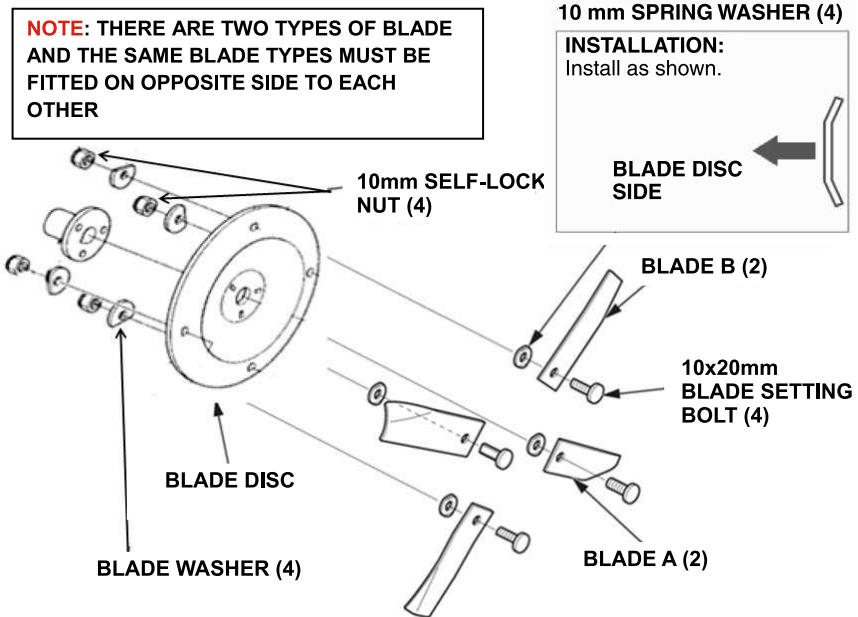

3. Tighten the self-lock nuts with a torque wrench. Prevent the blade disc from turning when tightening the self-lock nuts; tighten the self-lock nuts to the specified torque.

The blade setting bolts are specially designed for the mower. When you replace them, use only Honda genuine parts. Otherwise, the blade may detach from the mower and cause serious injury.

Self-lock nuts tightening torque:

34.3 ± 4.9 Nm (3.5 ± 0.5 kgf.m)

8. MAINTENANCE

4. Install the Thrust Washer, Woodruff Key, Blade Disc Holder, Blade/Blade Disc, Washers and Blade Disc Holder Bolt.

Diagram 1.1

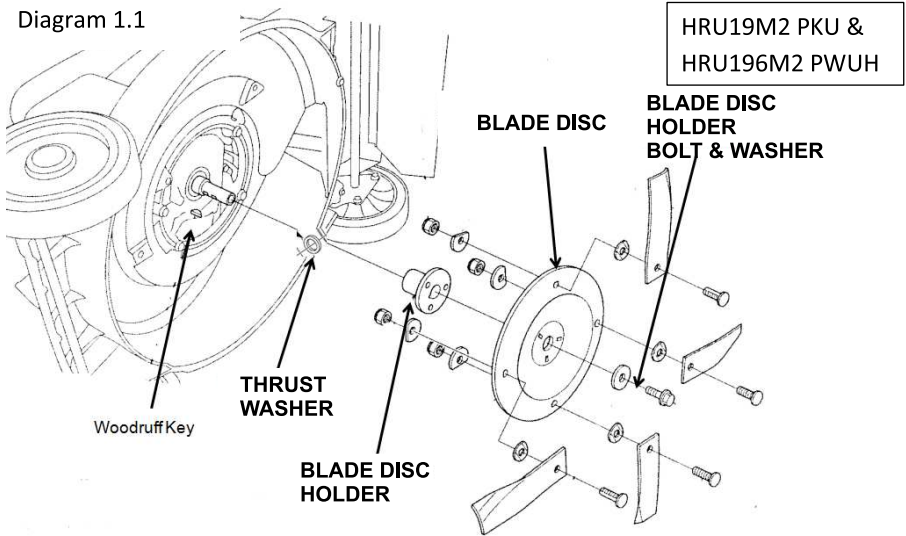

5. Hold the blade disc firmly and install the blade disc holder bolt. Ensure the disc is correctly seated before tightening.

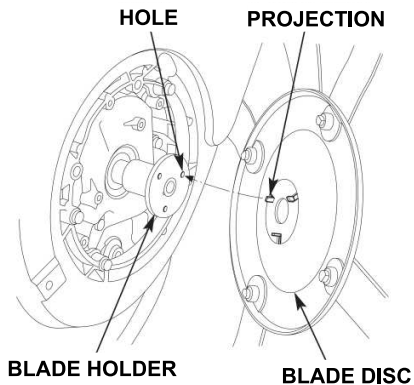

Tighten the blade disc holder with a torque wrench. Hold the blade disc firmly by inserting a suitable screwdriver through the blade disc to prevent it from turning when tightening the blade disc holder bolt.

Blade disc holder bolt tightening torque:

HRU19M2 PKU –Qty 1: 3/8 – 24 UNF (P/n90101-VB4-880)

39.2~49Nm (4.5±0.5 kgf.m)

HRU196M2 PWUH Qty 1:M10x1.25 (P/n90003-MN4-000)

49.1~ 58.9 Nm (5.5±0.5 kgf.m)

HRU196M2 PBUH & HRU216M3 TBUH – Qty 2: M10X1.25

(Part Number - 90105-VA3-000)

49.1~ 58.9 Nm (5.5±0.5 kgf.m)

6. After installing the blade/blade disc, check that it does not interfere with the housing. If the blades contact the housing, consult an authorised Honda servicing dealer.

 **WARNING**

A bent blade can be the cause of serious personal injury or accident.

If you do not have a torque wrench, have an authorised Honda servicing dealer tighten the blade setting bolts and the blade disc holder bolt before you use the mower. If the blade setting bolts and the blade disc holder bolt are over tightened, they could break. If the blade setting bolts and the blade disc holder bolt are not tightened enough, they could loosen or come out. In either case, it would be possible for the blade to fly off while you are operating the mower.

8. MAINTENANCE

GRASS CATCHER CLEANING AND REPLACEMENT

Grass Catcher Cleaning

Wash the Catcher with a garden hose and wipe / allow it to dry completely before storing the mower.

Grass Catcher Replacement

Replace a worn or damaged Catcher with a Honda genuine Catcher

All 19" Models

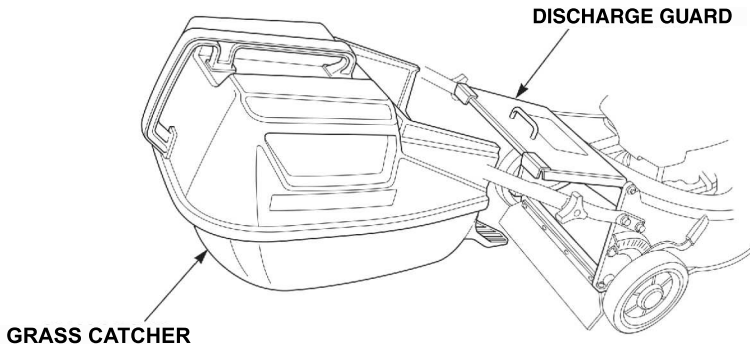

HRU216M3 TBUH

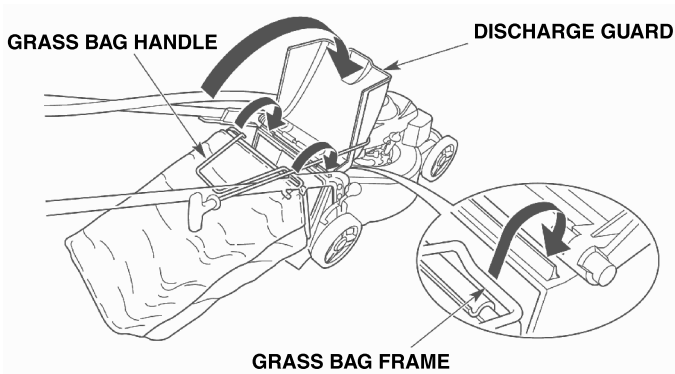

ENGINE PROBLEMS

Engine Will Not Start	Possible Cause	Correction
1. Check control positions, and ensure you are holding the Flywheel Brake Lever against the Handlebar.	Fuel valve OFF.	Turn fuel valve ON (page 8)
	Throttle lever in wrong position.	If applicable, move throttle lever to CHOKE position, unless the engine is warm (page 9).
2. Check fuel.	Out of fuel.	Refuel (page 18).
	Bad fuel; mower stored without treating or draining petrol or refuelled with bad petrol.	Drain fuel tank and carburettor (page 38). Refuel with fresh petrol (page 18).
3. Remove and inspect spark plug.	Spark plug faulty fouled or improperly gapped. Spark plug wet with fuel (flooded engine).	Clean, adjust or replace spark plug (page 47). Dry and reinstall spark plug. Start engine with throttle lever in HIGH position.
4. Take mower to an authorised Honda servicing dealer or refer to shop manual.	Fuel filter clogged, carburettor malfunction, ignition malfunction, valves stuck etc.	Replace or repair faulty components as necessary.

ENGINE PROBLEMS

Loss of Power	Possible Cause	Correction
1. Check throttle position.	Throttle not set to HIGH.	Move throttle to HIGH (page 9).
2. Check grass height.	Grass too tall to cut.	Raise cutting height (page 11), cut narrower swath (page 31) or cut more frequently.
3. Check under cutter housing.	Cutter housing clogged.	Clean out cutter housing (page 36).
4. Check air filter.	Air filter clogged.	Clean or replace air filter (page 46).
5. Check fuel.	Bad fuel; mower stored without treating or draining petrol or refuelled with bad petrol	Drain fuel tank and carburettor (page 38). Refuel with fresh petrol (page 18).
6. Take mower to an authorised Honda servicing dealer or refer to shop manual	Fuel filter clogged, carburettor malfunction, ignition malfunction, valves stuck etc.	Replace or repair faulty components as necessary.

9. TROUBLESHOOTING

VIBRATION PROBLEMS

Excessive Vibration	Possible Cause	Correction
1. Check cutter housing and blades.	Grass and debris lodged under cutter housing	Clean out cutter housing (page 36).
	Blade loose, damaged or unbalanced by improper sharpening.	Tighten loose blade bolts. Replace damaged blade (page 53).
2. Take mower to an authorised Honda servicing dealer to repair.	Mechanical damage, such as a bent crankshaft.	Replace or repair faulty components as necessary.

MOWING AND BAGGING PROBLEMS

Poor Cut Quality or Poor Mowing/Catching Performance	Possible Cause	Correction
1. Check that the throttle lever is in the HIGH position.	Engine speed is too slow to cut well.	Move throttle lever to the HIGH position (page 9)
2. Reduce Mowing speed.	You are pushing the Mower too fast for the lawn conditions.	Reduce your walking speed to a slower pace.
3. Check cutting height adjustment levers.	Adjustment lever is set at incorrect position.	Set lever at the correct height position (pages 11 and 22).
4. Check grass Catcher	Grass Catcher overfilled or clogged.	Empty the grass Catcher. Wash the Catcher if vent clogged with dirt (page 57).
5. Check the cutter housing and blades.	Cutter housing clogged.	Clean out the cutter housing (page 36).
	Blade dull, worn or damaged.	Sharpen or replace blade if necessary (page 50~55).
	Wrong blade installed.	Install correct blade (page 50~55).

10. SPECIFICATIONS

DIMENSIONS, WEIGHTS & CAPACITIES

NOTE: Overall heights and wheelbases are measured with cutting height set at 28mm [third position from the bottom].

ENGINE DESIGN AND PERFORMANCE

Model	HRU196M2PWUH	HRU196M2PBUH	HRU19M2PKU	HRU216M3TBUH
Overall Length	1395mm	1470mm	1415mm	1695mm
Overall Width	525mm	525mm	525mm	570mm
Overall Height	1000mm	1060mm	990mm	1050mm
Dry Weight	39.0kg	43.0kg	33.0kg	53kg
Wheel Base	520mm	520mm	520mm	625mm
Tread Fr	441mm	441mm	441mm	470mm
Rr	468mm	468mm	468mm	500mm
Cutting Width	470mm	470mm	470mm	530mm
Grass Catcher Capacity	54ℓ	54ℓ	54ℓ	70ℓ
Cutting Height	16 – 80mm (11 stages)	16 – 80mm (11 stages)	16 – 80mm (11 stages)	16 – 76mm (11 stages)
Fuel Tank Cap.	1.5ℓ	1.5ℓ	0.9ℓ	1.5ℓ

OPERATOR SAFETY FEATURES

Model	HRU19M2PKU	HRU196M2PWUH	HRU196M2PBUH	HRU216M3TBUH
FLYWHEEL BRAKE (FWB)	Y	Y	N	N
BLADE CONTROL (BBC)	N	N	Y	Y
AUTO CHOKE	Y	N	N	N
AUTO STOP	Y	Y	N	N

10. SPECIFICATIONS

ENGINE DESIGN AND PERFORMANCE

Model	HRU196M2PWUH
Engine Model	GXV160H2 MX3
Engine Type	4-stroke, overhead valve, single cylinder
Displacement	163cm ²
Bore and Stroke	68 x 45mm
Compression Ratio	8.0 ± 0.2
Ignition System	Transistor type magneto ignition
Fuel	Unleaded petrol with a pump octane rating of 91 or higher
Engine Oil	SAE 10W-30, API SG or higher
Engine Oil Capacity	0.65 ℓ
Spark Plug Type	BPR5ES (NGK), W16EPR-U (DENSO)
Spark Plug Gap	0.7 – 0.8mm
Maximum Engine Speed	3,200 + 0 rpm - 150 rpm
Idle Speed	1,700 ± 150 rpm
Valve Clearance (cold)	Intake: 0.15 ± 0.02mm Exhaust: 0.20 ± 0.02mm

ENGINE DESIGN AND PERFORMANCE

Model	HRU196M2PBUH
Engine Model	GXV160H2 MX4
Engine Type	4-stroke, overhead valve, single cylinder
Displacement	163cm ²
Bore and Stroke	68 x 45mm
Compression Ratio	8.0 ± 0.2
Ignition System	Transistor type magneto ignition
Fuel	Unleaded petrol with a pump octane rating of 91 or higher
Engine Oil	SAE 10W-30, API SG or higher
Engine Oil Capacity	0.65 ℓ
Spark Plug Type	BPR5ES (NGK), W16EPR-U (DENSO)
Spark Plug Gap	0.7 – 0.8mm
Maximum Engine Speed	3,200 + 0 rpm - 150 rpm
Idle Speed	1,700 ± 150 rpm
Valve Clearance (cold)	Intake: 0.15 ± 0.02mm Exhaust: 0.20 ± 0.02mm

10. SPECIFICATIONS

ENGINE DESIGN AND PERFORMANCE

Model	HRU19M2PKU
Engine Model	GCV170 MY06
Engine Type	4-stroke, overhead Valve, single cylinder
Displacement	166cm ³
Bore and Stroke	60 x 59mm
Compression Ratio	8.0 ± 0.2
Ignition System	Transistor type magneto ignition
Fuel	Unleaded petrol with a pump octane rating of 91 or higher
Engine Oil	SAE 10W-30, API SG or higher
Engine Oil Capacity	0.4 ℓ
Spark Plug Type	BPR5ES (NGK), W16EPR-U (DENSO)
Spark Plug Gap	0.7 – 0.8mm
Maximum Engine Speed	3,200 + 0 rpm - 150 rpm
Idle Speed	1,700 ± 150 rpm
Valve Clearance (cold)	Intake: 0.1 ± 0.02mm Exhaust: 0.1 ± 0.02mm

ENGINE DESIGN AND PERFORMANCE

Model	HRU216M3TBUH
Engine Model	GXV160H2 MX5
Engine Type	4-stroke, overhead Valve, single cylinder
Displacement	163cm ³
Bore and Stroke	68 x 45mm
Compression Ratio	8.0 ± 0.2
Ignition System	Transistor type magneto ignition
Fuel	Unleaded petrol with a pump octane rating of 91 or higher
Engine Oil	SAE 10W-30, API SG or higher
Engine Oil Capacity	0.65 ℓ
Spark Plug Type	BPR5ES (NGK), W16EPR-U (DENSO)
Spark Plug Gap	0.7 – 0.8mm
Maximum Engine Speed	3,000 + 0 rpm - 150 rpm
Idle Speed	1,700 ± 150 rpm
Valve Clearance (cold)	Intake: 0.15 ± 0.02mm Exhaust: 0.20 ± 0.02mm

11. SET-UP INSTRUCTIONS

UNPACKING

Remove upper and lower catcher from the box as well the catcher handle and owner's manual. Discard any protective cardboard from the mower, including the piece around the handlebar.

Handlebar Setup

1. Loosen the Handle Joint Grips from the handlebar to the lower handle stays enough so you can raise the handlebar into the normal position. (Don't fully remove the grip handle joint or you may lose the washer)
2. Tighten the Handle Joint Grip to secure the handle in the correct operating position.
3. Remove the temporary wire band from lever on upper handle.
4. Fill Engine with appropriate Engine Oil (Page 45)
5. Fill Fuel tank with fresh Unleaded Petrol (Page 18)
6. Start and Run Engine.

12. SERVICE SCHEDULE SHEET

Service Record First Year

1ST MONTH OR 20 HOUR SERVICE

Hours Use (Tanks x Hrs/Tank)	Date	Notes

Servicing Dealer Stamp	Date: _____
------------------------	-------------

EVERY 6 MONTH OR 100 HOUR SERVICE

Hours Use (Tanks x Hrs/Tank)	Date	Notes

Servicing Dealer Stamp	Date: _____
------------------------	-------------

Record further services here: Service Record

NEXT SERVICE

Hours Use (Tanks x Hrs/Tank)	Date	Notes

Servicing Dealer Stamp	Date: _____
------------------------	-------------

NEXT SERVICE

Hours Use (Tanks x Hrs/Tank)	Date	Notes

Servicing Dealer Stamp	Date: _____
------------------------	-------------

TIP: An easy way to keep track of the hours your Honda lawnmower has done is to record how many hours you get from a tank of fuel, then simply record the number of tanks used. **TANKS X HOURS per TANK = TOTAL HOURS USE.**

NOTES

HONDA



Part Number: C90900

Printed by Kenmark Press July 2018
20,000 Print Run