

ZT 34" [AGU915344]

TABLE OF CONTENTS

AGU915344 Unit	3
AGU915344 Belt Guard & Baffle - 34"	5
AGU915344 Continuity Diagram	7
AGU915344 Control Panel	9
AGU915344 Decals - Safety	11
AGU915344 Decals - Style 34"	13
AGU915344 Deck Lift - 34" (1)	15
AGU915344 Deck Lift - 34" (2)	17
AGU915344 Deck, Belt, Blades & Spindles - 34"	19
AGU915344 Discharge Chute - 34"	21
AGU915344 Electrical	23
AGU915344 Engine - Ariens 635cc	26
AGU915344 Fenders	28
AGU915344 Frame	30
AGU915344 Front & Rear Wheels - 34"	32
AGU915344 Fuel System	34
AGU915344 Idlers & Sheaves - 34"	36
AGU915344 Muffler Guarding	38
AGU915344 Parking Brake	40
AGU915344 Rear Wrap & Engine Guards	43
AGU915344 Seat & Seat Support	45
AGU915344 Steering Controls	47
AGU915344 Transaxles & Idler Pulley - 34"	50
AGU915344 Wiring Diagram	53

AGU915344 Unit



Rendered by LeadVenture, Inc.

AGU915344 Unit

Ref Number	Part Number	Part Description	Context Notes	Quantity
1	AGU915344	ZT 34 - ARIENS POWERED 635CC TWIN, 34" STAMPED STEEL DECK		1

AGU915344 Belt Guard & Baffle - 34"

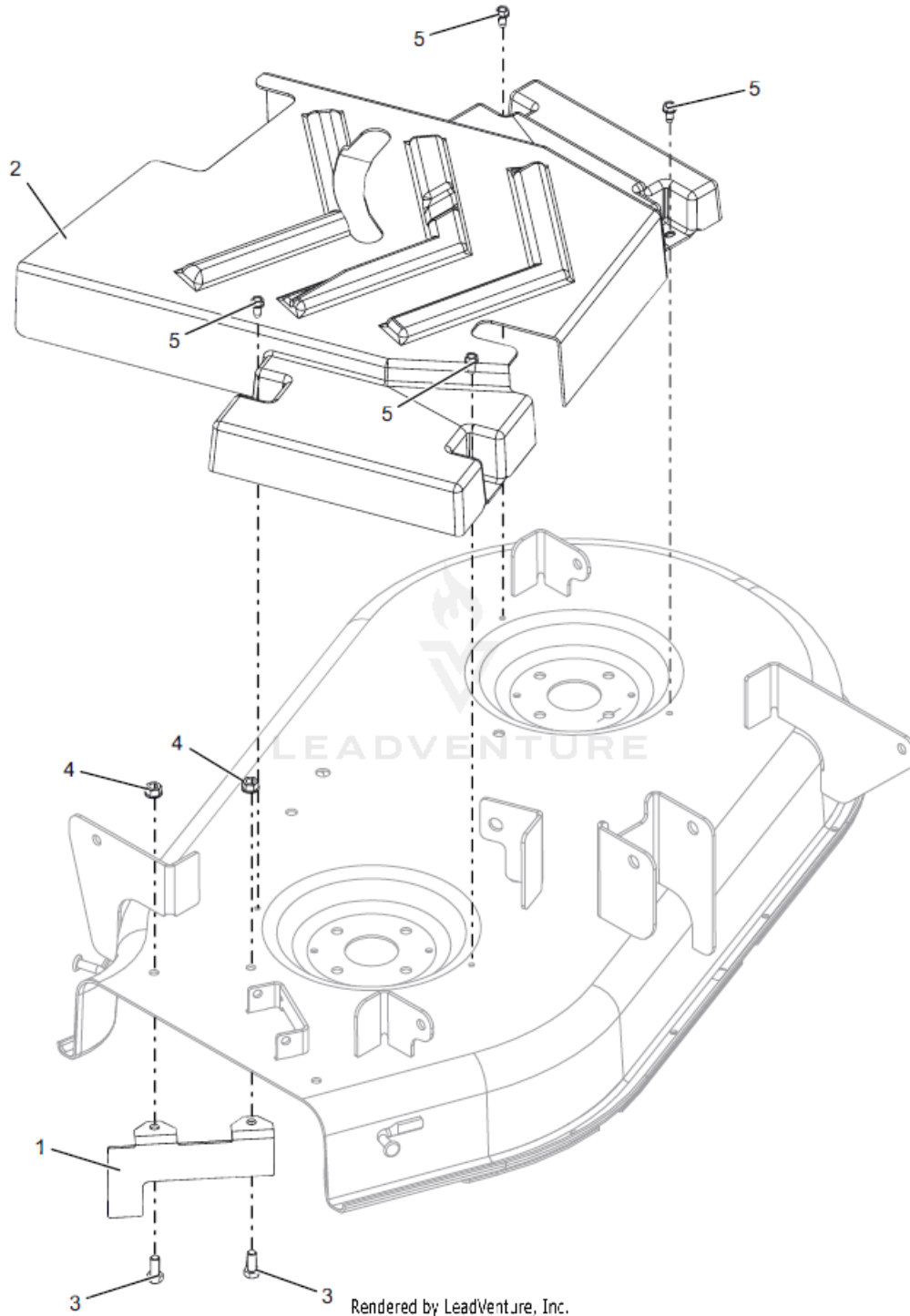

Rendered by LeadVent.ure, Inc.

AGU915344 Belt Guard & Baffle - 34"

Ref Number	Part Number	Part Description	Context Notes	Quantity
1	AGP03779253	BRKT-BAFFLE, DISCHARGE 34"		1
2	AGP14810300	GUARD, CENTER EDGE 34 DECK		1
3	AGP05901704	BLT,HEX .31-18X.75 G5 ZCC		2
4	AGP06500840	NUT,LK-CTR-FLG .31-18 GF ZCC		2
5	AGP07400122	SCR-TAP .25-20X.50 HWH ZCC		4

AGU915344 Continuity Diagram

The diagrams below show the various states of connection for electrical components.
 The solid lines on switches show continuity.
 NOTE: All switches are viewed from the rear.

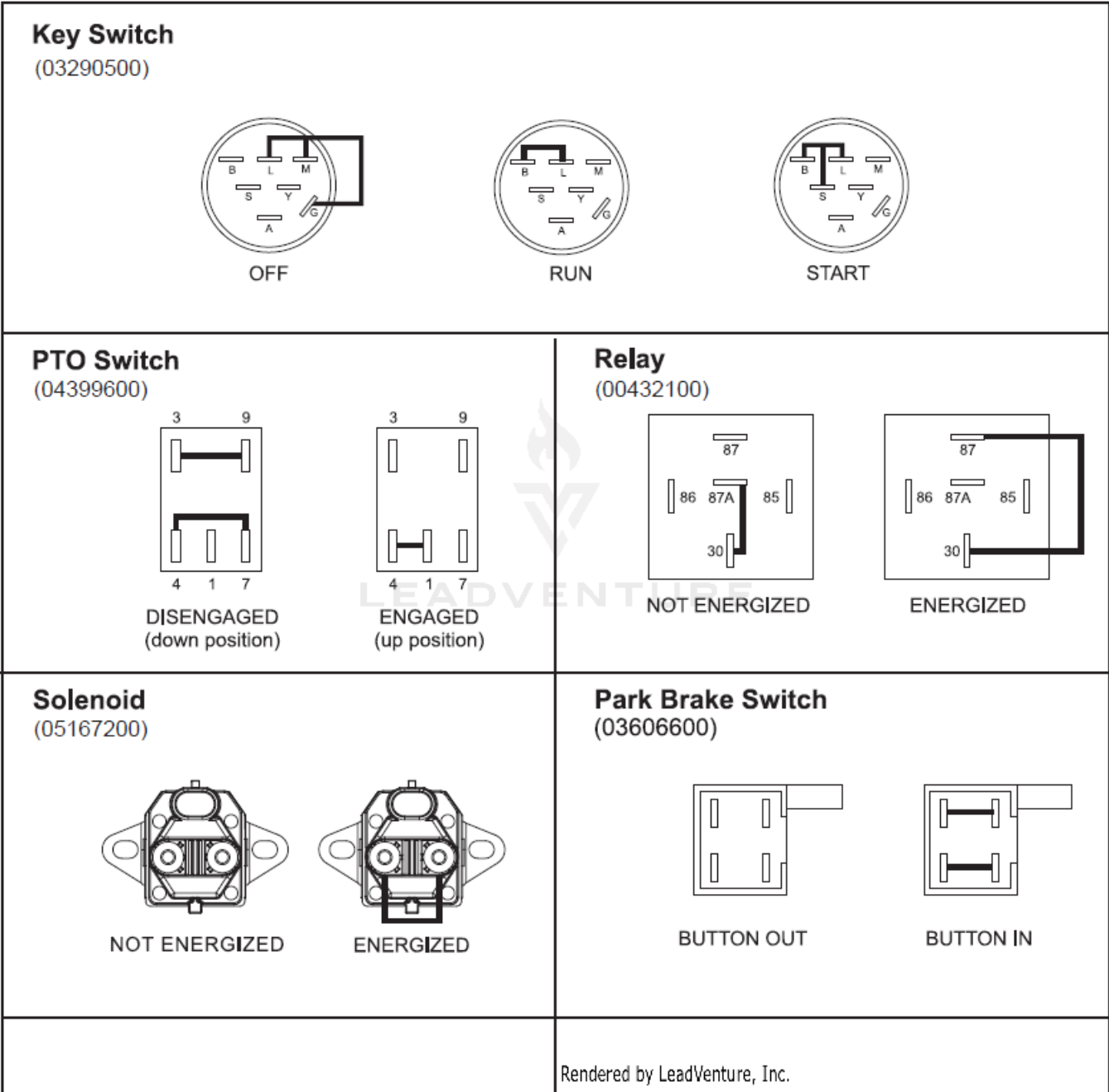

AGU915344 Continuity Diagram

Ref Number	Part Number	Part Description	Context Notes	Quantity
-------------------	--------------------	-------------------------	----------------------	-----------------

AGU915344 Control Panel

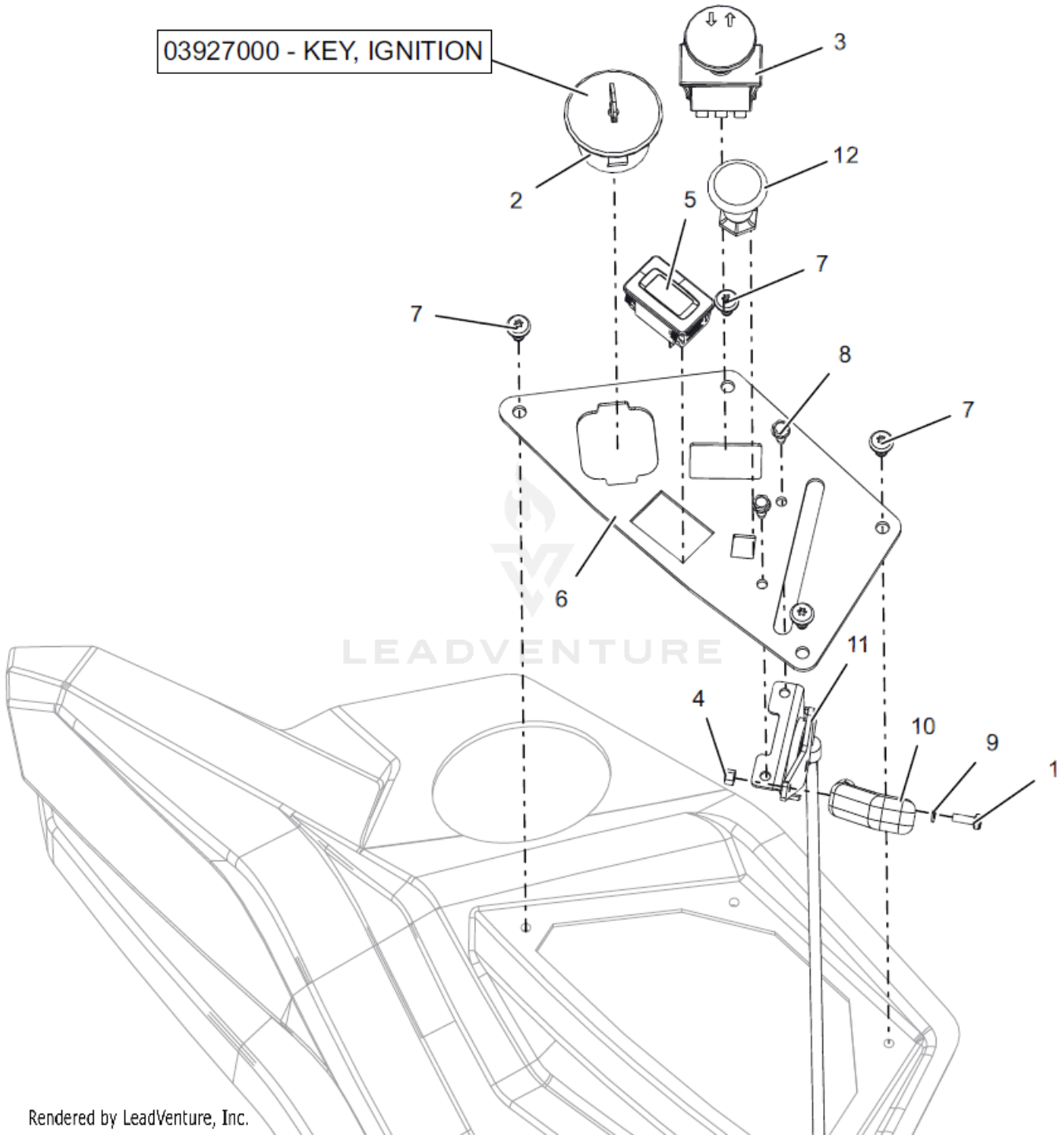

Rendered by LeadVenture, Inc.

AGU915344 Control Panel

Ref Number	Part Number	Part Description	Context Notes	Quantity
1	AGP02826300	M4 X 12 POZI PAN MACHINE SCREW		1
2	AGP03290500	KEYSWITCH-IGNITION 3 POS		1
3	AGP04399600	SWITCH, CLUTCH (YELLOW)		1
4	AGP04826400	NUT, NYLOC M4		1
5	AGP05254800	HOUR METER		1
6	AGP05288053	PANEL, CONTROL (RED)		1
7	AGP07400123	SCR-PAN .25-15X.50 6L H/LZB500		4
8	AGP07400130	SCR,TAP #10-24X.50 HWH TR ZCC		2
9	AGP08826200	CAP,TANK		1
10	AGP14810400	KNOB, CONTROL		1
11	AGP52804000	THROTTLE, LONCIN LC2P76F 635CC		1
12	AGP529469800	CABLE, CHOKE		1
13	AGP03927000	KEY, 03290500 KEYSWITCH	SERVICE PART	1

AGU915344 Decals - Safety

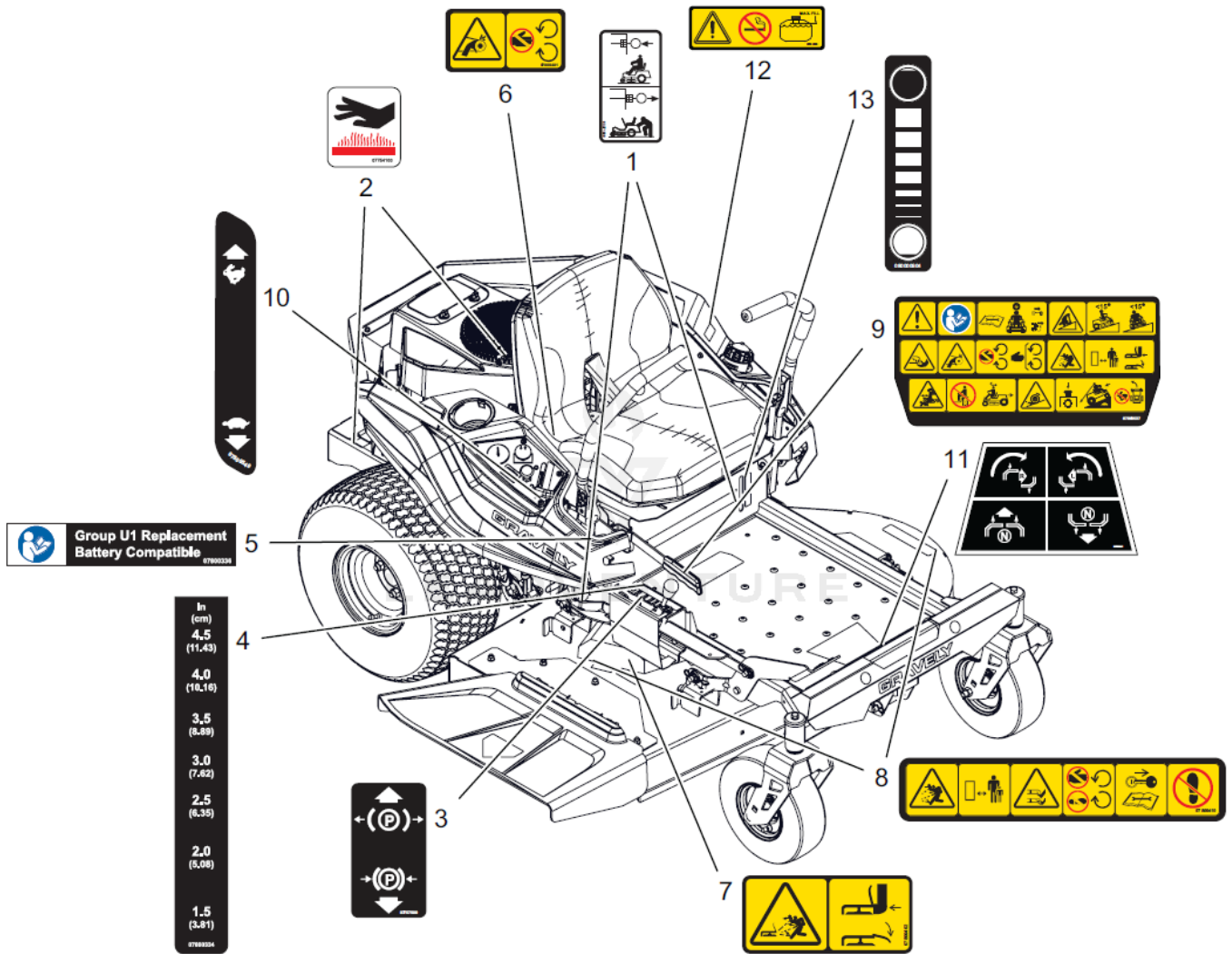

Rendered by LeadVenture, Inc.

AGU915344 Decals - Safety

Ref Number	Part Number	Part Description	Context Notes	Quantity
1	AGP03271900	DECAL, TRANSMISSION DISCONNECT		2
2	AGP07754100	DECAL, HOT SURFACE		2
3	AGP07757500	DECAL, PARKING BRAKE LEVER		1
4	AGP07800334	AGPDECAL, HEIGHT OF CUT		1
5	AGP07800336	DECAL, U1 BATTERY REPLACEMENT		1
6	AGP07800401	DECAL, SAFETY - GUARDING		1
7	AGP07800402	DECAL, SAFETY - DECK GUARDING		1
8	AGP07800410	DECAL, DECK SAFETY		2
9	AGP07800537	DECAL, MAIN SAFETY		1
10	AGP07800540	DECAL, DASH DECAL		1
11	AGP07800541	DECAL, STEERING		1
12	AGP07800820	DECAL, FUEL WARNING		1
13	AGP08000604	DECAL, FUEL LEVEL		1

AGU915344 Decals - Style 34"

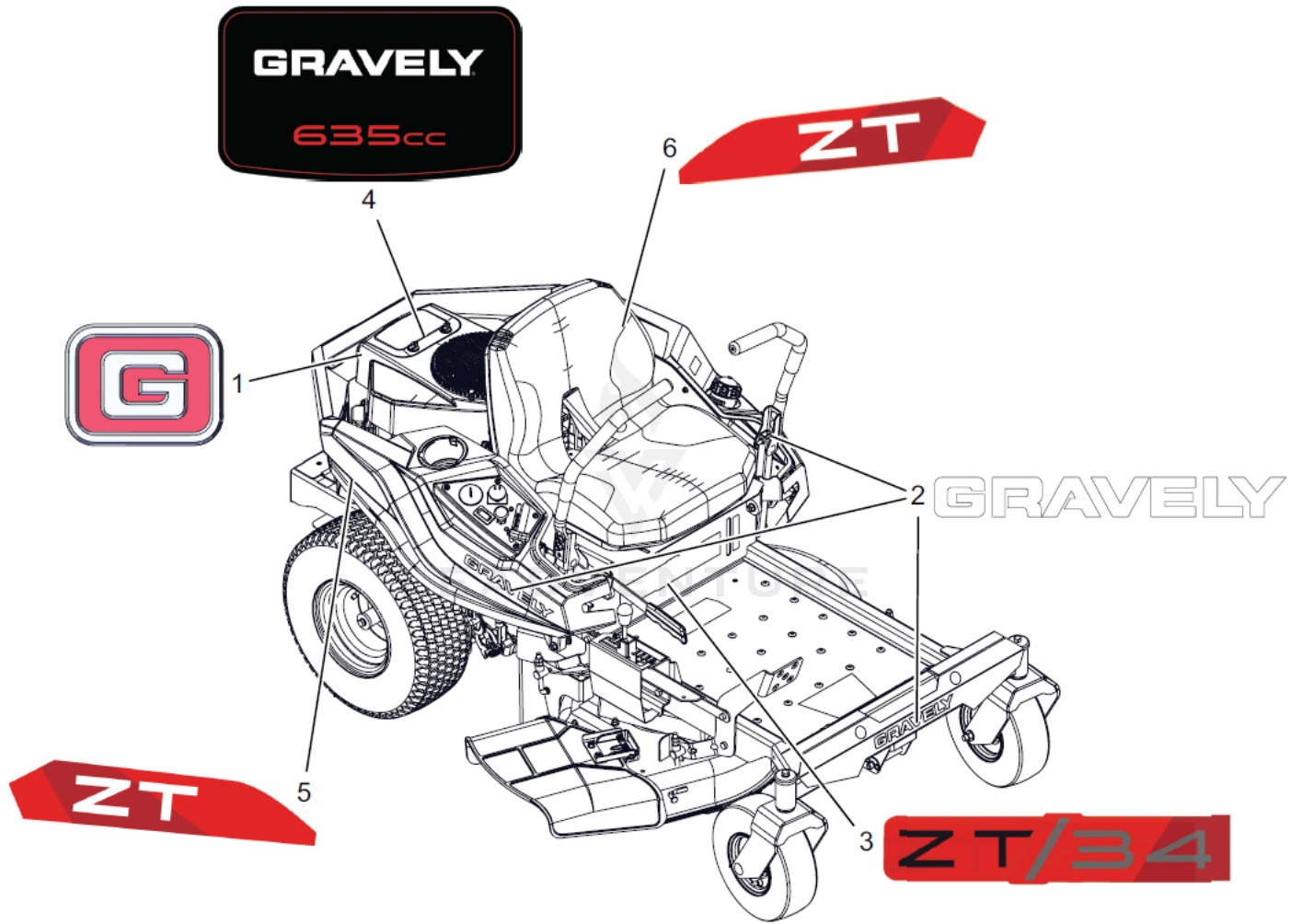

Rendered by LeadVenture, Inc.

AGU915344 Decals - Style 34"

Ref Number	Part Number	Part Description	Context Notes	Quantity
1	AGP07800534	DECAL, GRAVELY BRAND		1
2	AGP07800618	DECAL, 9.5" GRAVELY LOGO		3
3	AGP359554600	DECAL, GRAVELY ZT / 34		1
4	AGP35902400	DECAL, ENGINE 635CC		1
5	AGP359554800	DECAL, ZT RH FENDER		1
6	AGP359554900	DECAL, ZT LH FENDER		1

AGU915344 Deck Lift - 34" (1)

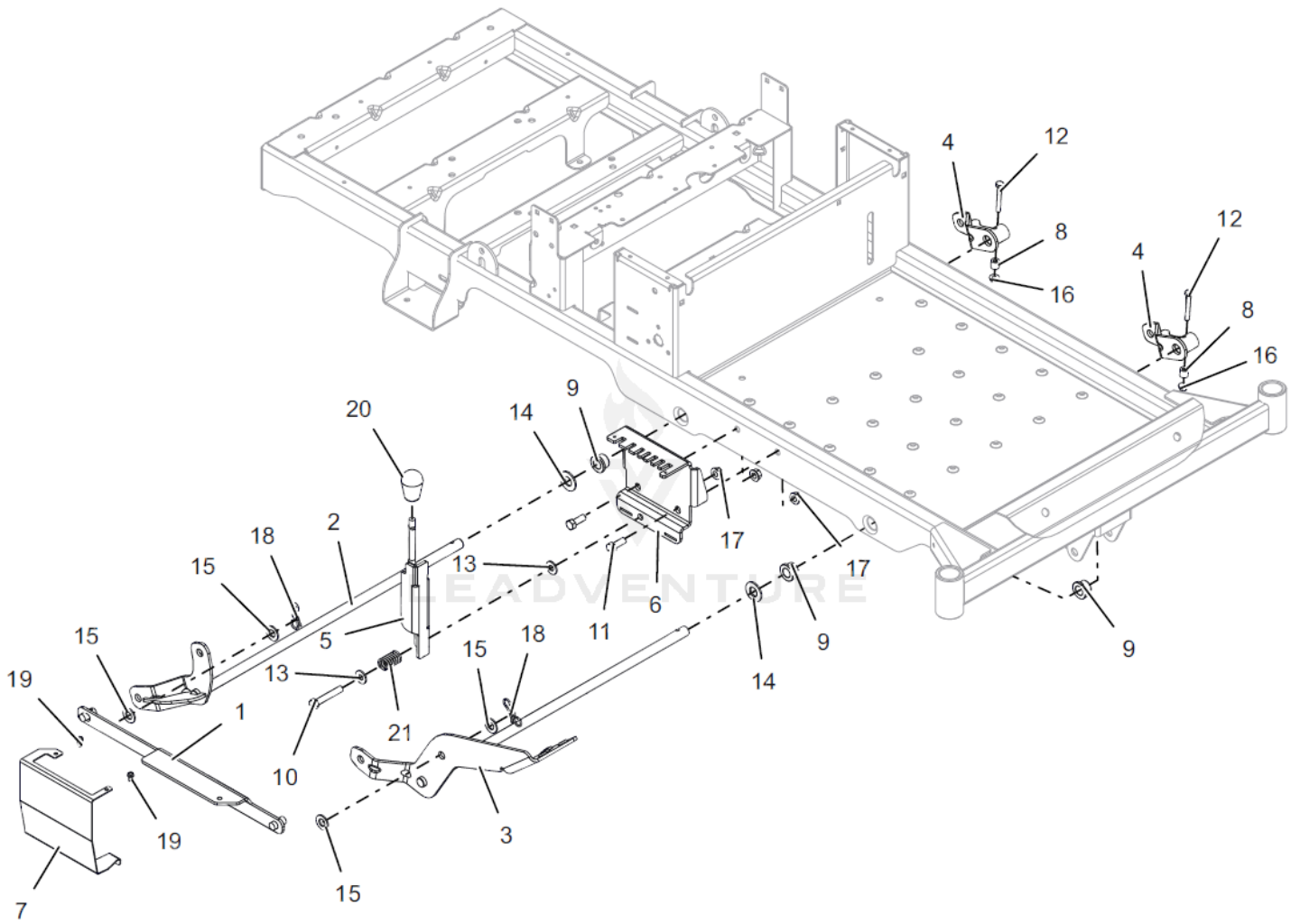

Rendered by LeadVenture, Inc.

AGU915344 Deck Lift - 34" (1)

Ref Number	Part Number	Part Description	Context Notes	Quantity
1	AGP04377300	WLDMT, LIFT / HOC LINK (RED)		1
2	AGP04434453	WLDMT, REAR DECK LIFT (RED)		1
3	AGP04434553	WLDMT, FOOTPEDAL (RED)		1
4	AGP04434653	WLDMT, DECK LIFT ARM (RED)		2
5	AGP09178953	WLDMT, HEIGHT OF CUT (RED)		1
6	AGP04377953	PLATE, HEIGH ADJUSTMENT (RED)		1
7	AGP04723753	GUARD, DECK HOC (RED)		1
8	AGP05501112	BSHG-SLV .265X.500X.500		2
9	AGP05519100	BSHG-FLG .629X.879X.469X1.250		4
10	AGP05901640	BLT,HEX .38-16X2.25 G5 ZCC		1
11	AGP05901711	BLT,HEX .375-16X1 GR5 ZC120		2
12	AGP05901740	BLT, HEX .25-20X2.00 G5 ZCC		2
13	AGP06401023	WSHR,FLT .375X.875X.083 ZCC		2
14	AGP06401118	WSHR, FLT .656X1.313X.095 ZCC		2
15	AGP06443300	WSHR-FL-NYL .518X1.000X.080		4
16	AGP06500821	NUT-LK-CTR-FLG .25-20 ZC120		2
17	AGP06500901	NUT-LK-CTR-FLG .375-16 GF ZCC		3
18	AGP06700220	PIN, BOWTIE .091X1.875 ZCC		2
19	AGP07400130	SCR,TAP #10-24X.50 HWH TR ZCC		2
20	AGP07500224	KNOB,SOFT TEARDROP,PUSH-ON BLK		1
21	AGP08300631	SPRG, COMPRESSION		1

AGU915344 Deck Lift - 34" (2)

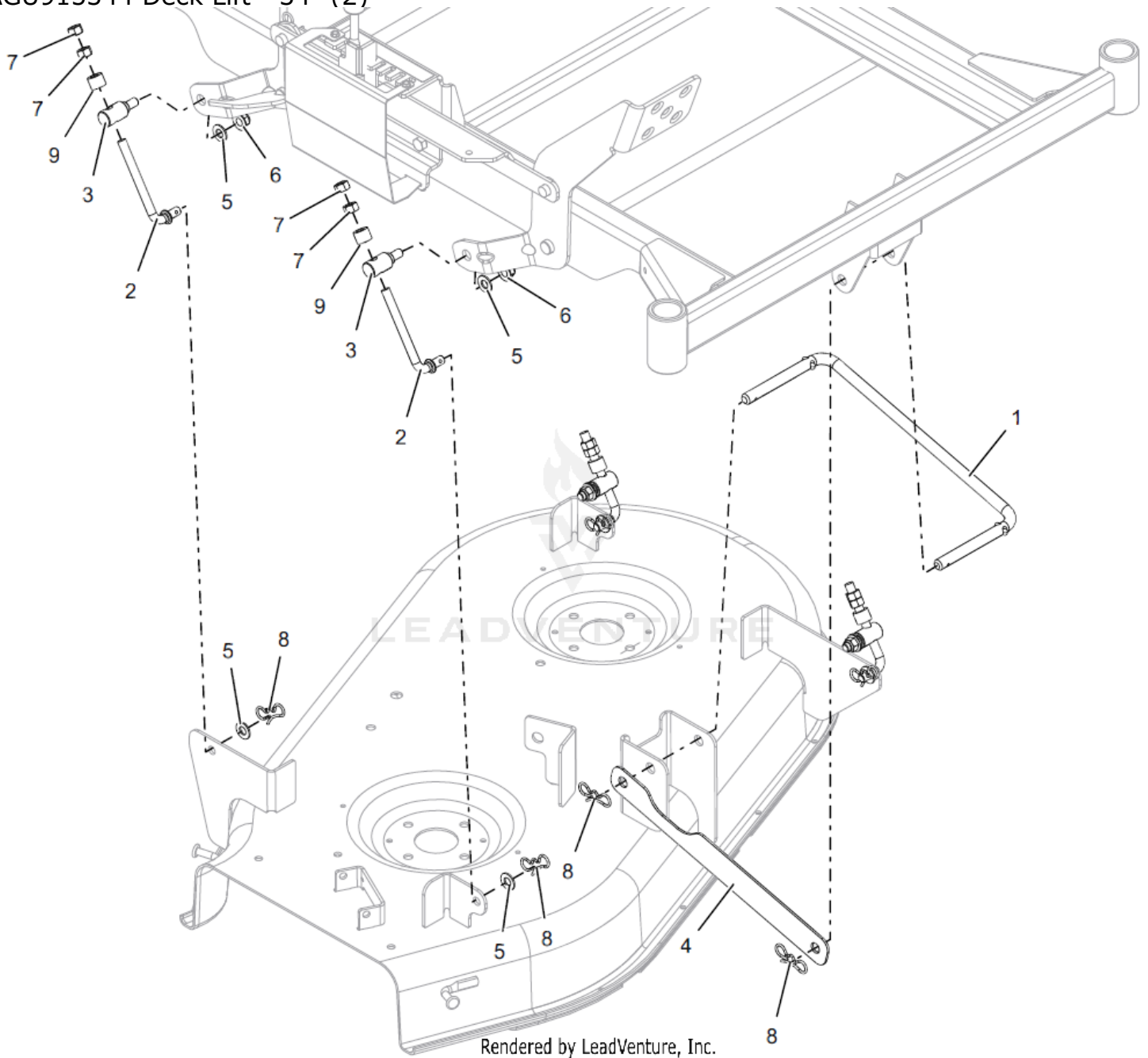

Rendered by LeadVenture, Inc.

AGU915344 Deck Lift - 34" (2)

Ref Number	Part Number	Part Description	Context Notes	Quantity
1	AGP04377600	WIREFORM, DRAG LINK		1
2	AGP04377700	WIREFORM, DECK ADJUSTMENT		4
3	AGP04377800	TRUNNION, DECK ADJUSTER		4
4	AGP04424900	STRAP, DRAG LINK		1
5	AGP06401013	WSHR,FLT .406X.812X.065 ZCC		8
6	AGP06500726	NUT,NYL-FLG .38-16 GF ZCC		4
7	AGP06500917	NUT-STD .375-16 G2 ZCC		8
8	AGP06700220	PIN, BOWTIE .091X1.875 ZCC		6
9	AGP08553700	BSHG-SLV .391X.688X.52 PM		4

AGU915344 Deck, Belt, Blades & Spindles - 34"

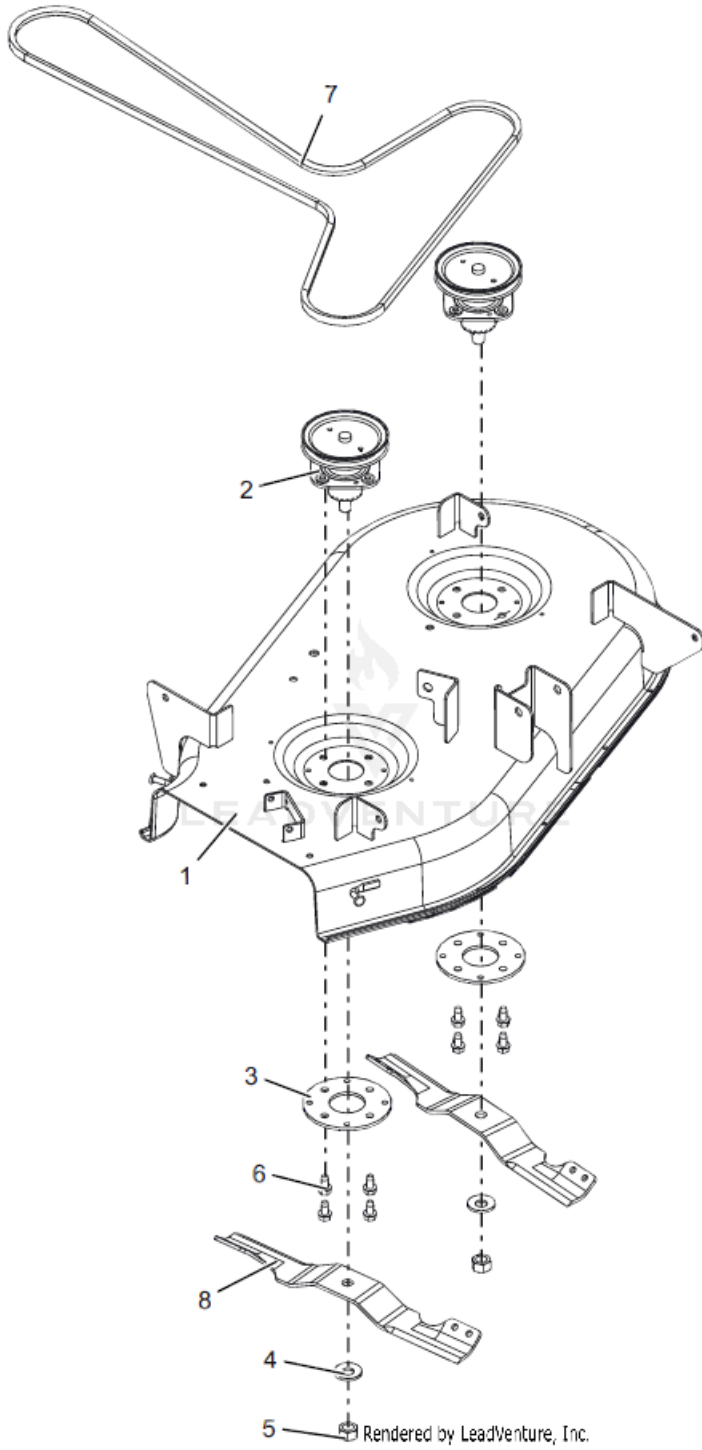

AGU915344 Deck, Belt, Blades & Spindles - 34"

Ref Number	Part Number	Part Description	Context Notes	Quantity
1	AGP04379953	WLDMT, DECK 34" ZOOM/ZT		1
2	AGP51519500	KIT, DECK SPINDLE ASM (34/50)		2
3	AGP03839053	PLATE-REINF, SPINDLE		2
4	AGP06445700	WSHR-BLVL .669X1.535X.138		2
5	AGP06500920	NUT-STD .625-18 ZCC		2
6	AGP07400129	SCR,TAP .375-16X.75 HWH TR ZCC		8
7	AGP07200116	V-BELT, HA-WRAPPED		1
8	AGP03971900	BLADE, MOWER 17.35		2

AGU915344 Discharge Chute - 34"

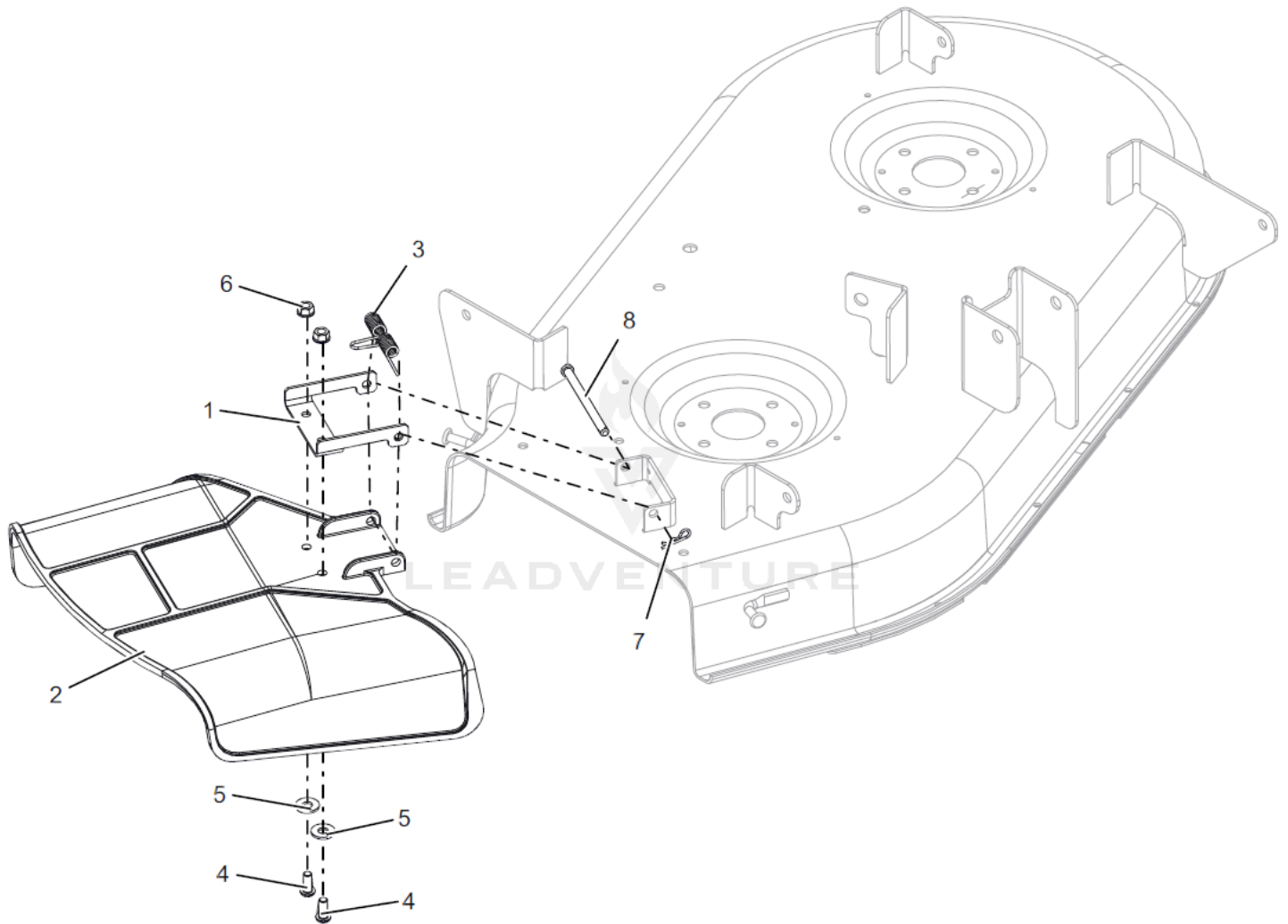

Rendered by LeadVenture, Inc.

AGU915344 Discharge Chute - 34"

Ref Number	Part Number	Part Description	Context Notes	Quantity
1	AGP549311153	CHUTE, REINFORCEMENT (RED)		1
2	AGP03994300	CHUTE, SIDE DISCHARGE		1
3	AGP01258100	SPRING, TORSION		1
4	AGP05920900	SCR-SKH .31-18X.75 BTNHD YWZC		2
5	AGP06401023	WSHR,FLT .375X.875X.083 ZCC		2
6	AGP06500840	NUT,LK-CTR-FLG .31-18 GF ZCC		2
7	AGP06700222	PIN, HAIR #213 .08X1.19 ZCC		1
8	AGP06800002	PIN, 5/16 X 3.88"		1

AGU915344 Electrical

Service Numbers:
(1) 00432100 - Relay
(1) 00524600 - Fuse -30A
(2) 09293500-Diode Connector Shell

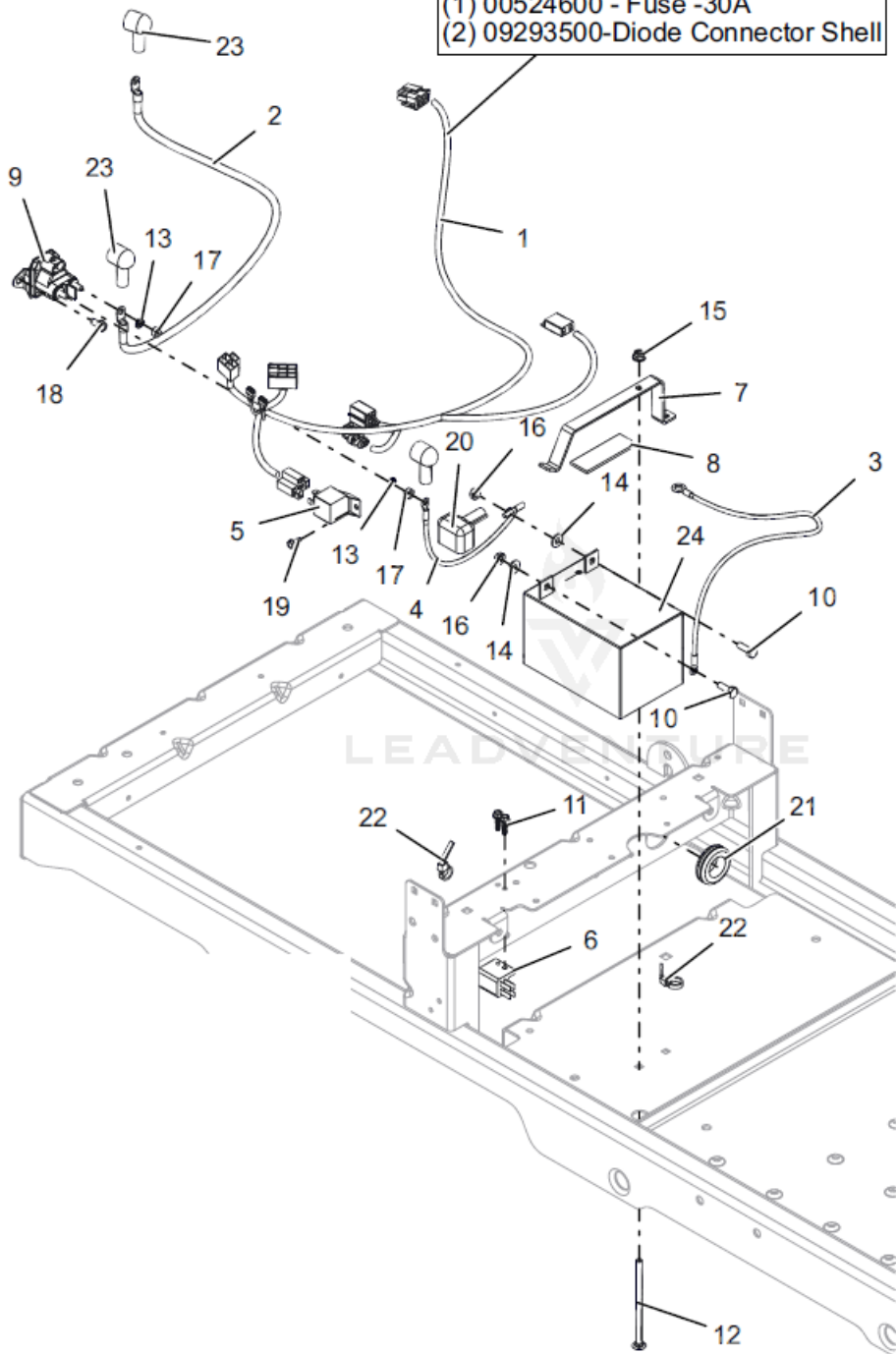

Rendered by LeadVenture, Inc.

AGU915344 Electrical

Ref Number	Part Number	Part Description	Context Notes	Quantity
1	AGP05296700	HARNESS, ZOOM / ZT WIRE		1
2	AGP04783400	CABLE, POS W/(2)1/4 RING 21.5LG		1
3	AGP04249900	CABLE, NEGATIVE 26" 6 GA.		1
4	AGP04787400	CABLE, POS W/2 1/4 RING 15.0 LG		1
5	AGP00432100	RELAY, SEALED W/DIODE		1
6	AGP03606600	SWITCH- DOUBLE POLE N.O./N.O.		1
7	AGP04385351	HOLDDOWN, BATTERY, U1&190CCA		1
8	AGP04850000	PAD, RBR 1.0"X3.0" W/ADHESIVE		1
9	AGP05167200	SOLENOID, STARTER (SEALED)		1
10	AGP05901716	BLT, HEX .25-20X.75 G5 ZCC		2
11	AGP06100232	SCR, PLASTITE-HWH 0.2 X 0.75 ZC120		2
12	AGP06200308	BLT, RHSN .25-20X4.50 G5 ZCC		1
13	AGP06300118	WSHR, LK- EXT.262X.502X.026 ZCC		2
14	AGP06401001	WSHR, FLT .281X.625X.065 ZCC		2
15	AGP06500813	NUT, NYL-FLG .25-20 GF ZCC		1
16	AGP06500921	NUT-KEPS .250-20 ZCC		2
17	AGP06500925	NUT-STD M6-1.0 ZCC		2
18	AGP07400122	SCR-TAP .25-20X.50 HWH ZCC		1
19	AGP07415800	@SCR-TAP 10-24X.50 HWH TR YWZC		1
20	AGP07505700	INSULATOR		1
21	AGP07506500	GROMMET 1.0ID X 1.38 OD		1

Ref Number	Part Number	Part Description	Context Notes	Quantity
22	AGP07517300	CABLE TIE LG 5-1/2		2
23	AGP07533200	BOOT, EYELET TERMINAL		3
24	AGP458141900	YUASA 895UR1 BATTERY		1
25	AGP00432100	RELAY,SEALED W/DIODE	SERVICE PART	1
26	AGP00524600	FUSE, 30 AMP.	SERVICE PART	1
27	AGP09293500	DIODE, CONNECTOR SHELL	SERVICE PART	2

AGU915344 Engine - Ariens 635cc

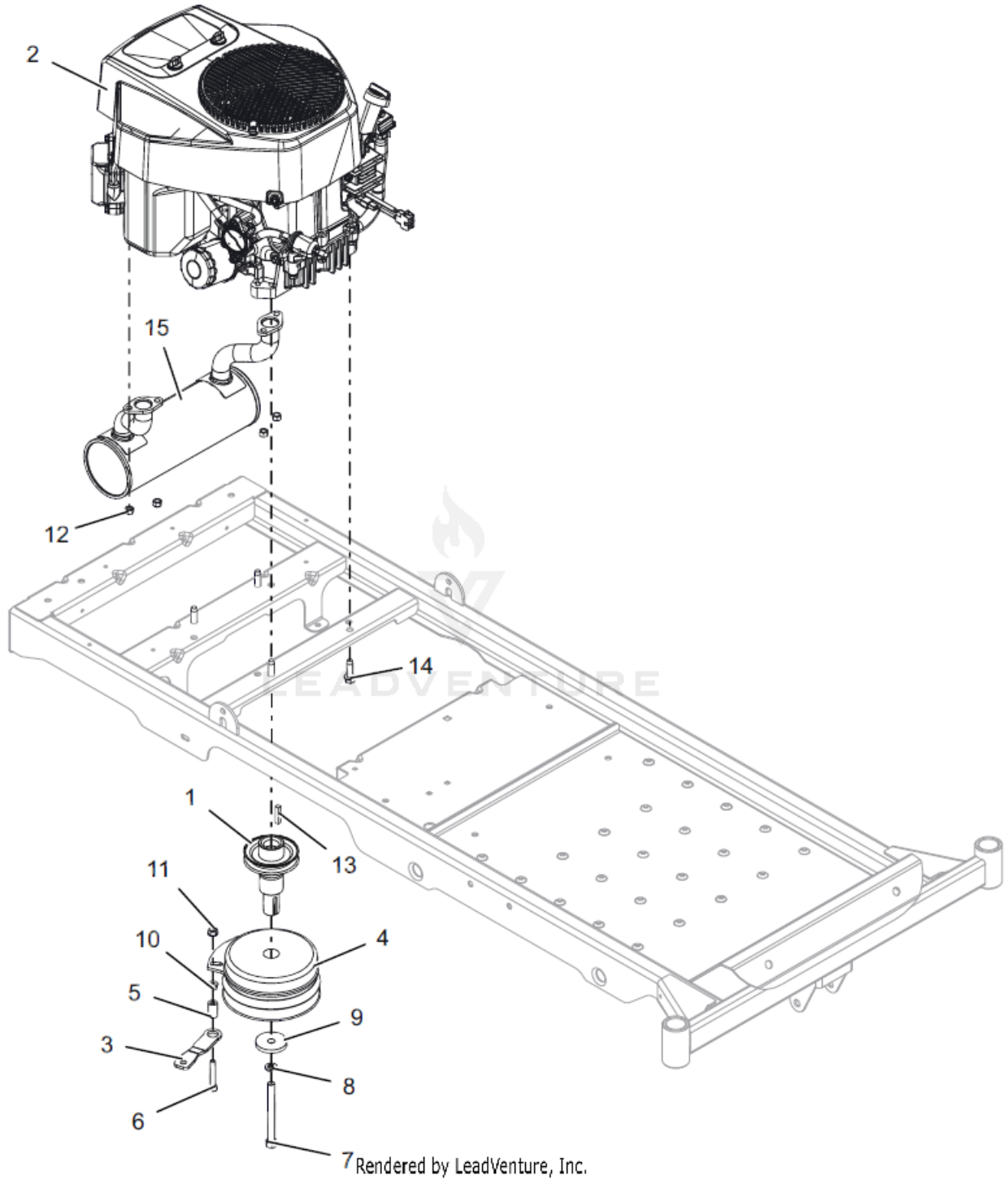

7 Rendered by LeadVenture, Inc.

AGU915344 Engine - Ariens 635cc

Ref Number	Part Number	Part Description	Context Notes	Quantity
1	AGP07350500	WLDMT- CRANKSHAFT EXT.- BRIGGS		1
2	AGP159340600	ENGINE, ARIENS 635CC		1
3	AGP03956700	BRKT, CLUTCH		1
4	AGP03972700	CLUTCH, 105 FT*LB MONO POLE		1
5	AGP03980200	SPACER, RUBBER 5/16 IDX1.0 LG		1
6	AGP05901805	BLT, HEX .31-18X2.00 G5 ZCC		1
7	AGP05901820	BLT, HEX .44-20X4.50 G8 ZCC NT		1
8	AGP06300121	WSHR, LK-REG .438X.109 ZCC		1
9	AGP06401111	WSHR, FLT .469X2.00X.250 ZCC		1
10	AGP06500815	NUT,SPNLK-FLG .31-18 G5 ZCC		1
11	AGP06500840	NUT,LK-CTR-FLG .31-18 GF ZCC		1
12	AGP06500919	NUT-LK-TOP-FLG M8 ZCC		4
13	AGP06603400	KEY-SQ .25 X 1.25 X .25 SAE		1
14	AGP07400128	SCR,TAP .375-16X1.25HWH TR ZCC		4
15	AGP32112900	WLDMT, LONCIN MUFFLER 635CC		1

AGU915344 Fenders

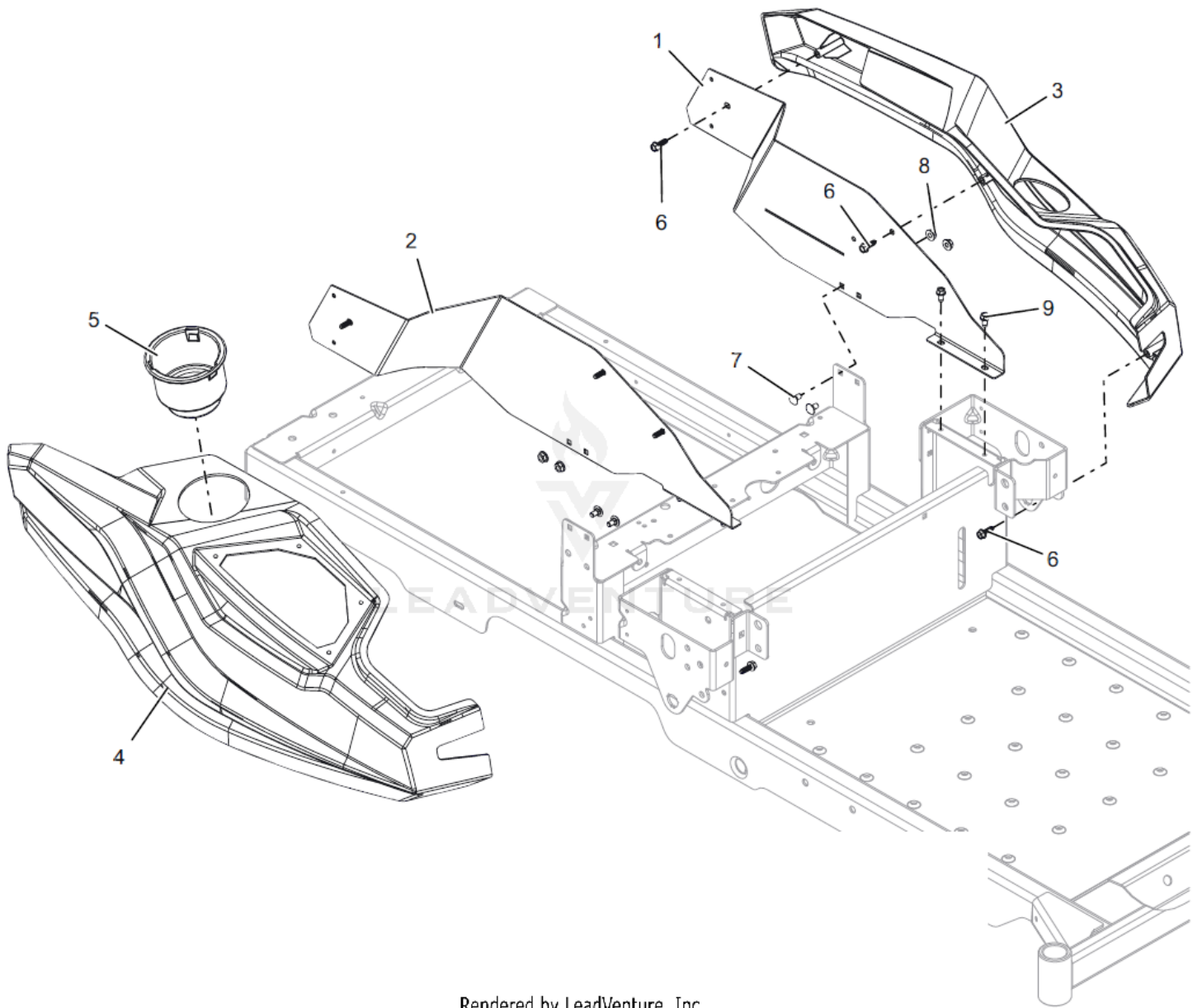

Rendered by LeadVenture, Inc.

AGU915344 Fenders

Ref Number	Part Number	Part Description	Context Notes	Quantity
1	AGP05287653	BRKT, FENDER MOUNTING LH (RED)		1
2	AGP05287753	BRKT, FENDER MOUNTING RH (RED)		1
3	AGP51535600	KIT-FENDER WITH DECAL		1
4	AGP05289100	FENDER, RH - ZOOM		1
5	AGP04192700	CUPHOLDER, SNAP-IN 3.75OD		1
6	AGP06100231	SCR, PLASTITE-HWH 0.25 X 0.75 ZC120		7
7	AGP06200306	BLT, RHSN .25-20X.500 G5 ZCC		4
8	AGP06500821	NUT-LK-CTR-FLG .25-20 ZC120		4
9	AGP07400122	SCR-TAP .25-20X.50 HWH ZCC		4

AGU915344 Frame

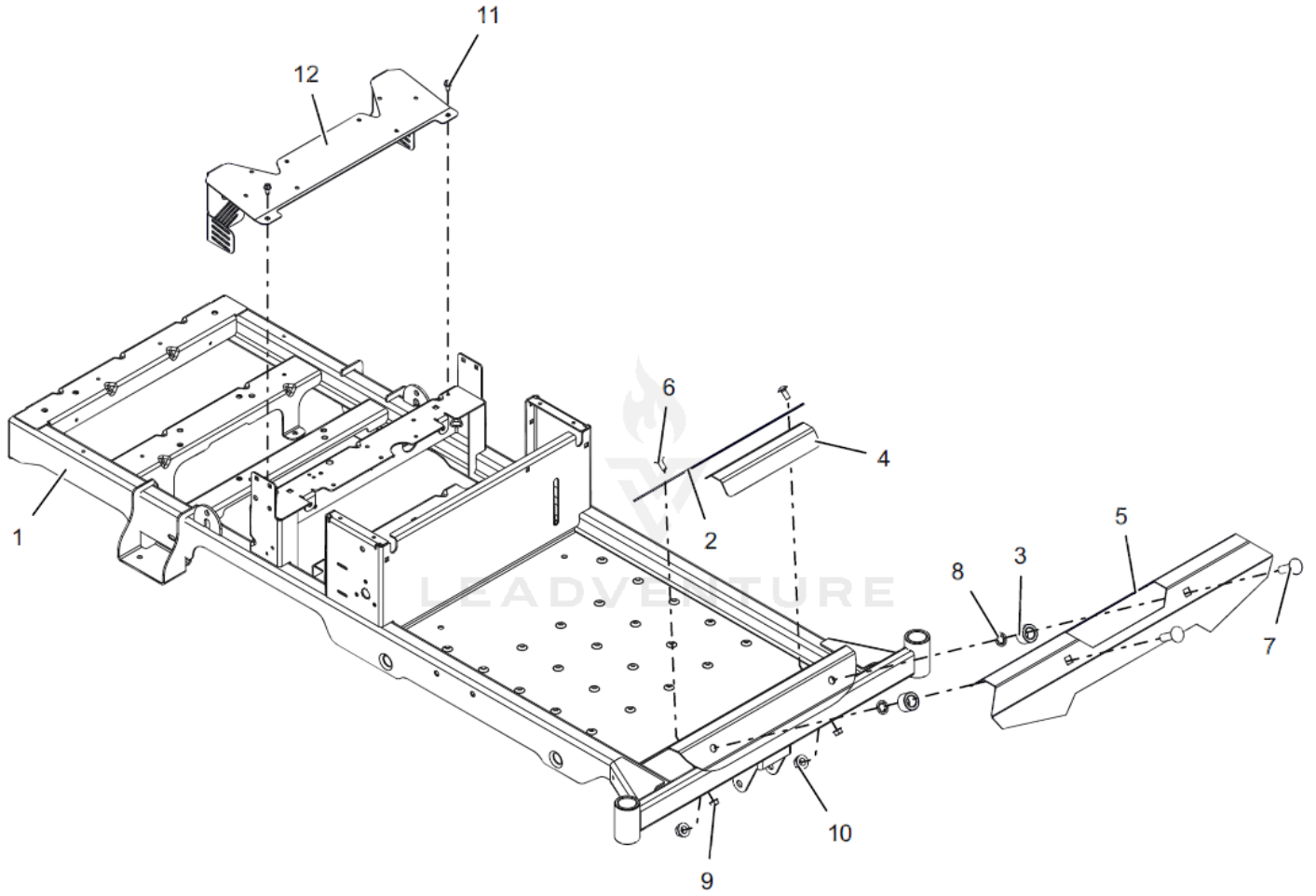

Rendered by LeadVenture, Inc.

AGU915344 Frame

Ref Number	Part Number	Part Description	Context Notes	Quantity
1	AGP05288953	WLDMT, FRAME-EDGE (RED)		1
2	AGP03833800	GRIP, ADHESIVE (1" X 16" BLK)		1
3	AGP04192901	TUBE, UPPER CONTROL PIVOT		2
4	AGP05109100	GRIP, STEP		1
5	AGP05291200	FOOTREST, RED		1
6	AGP06200309	BLT, RHSSN.31-18X.750 G5 ZCC		2
7	AGP06200330	BLT,RHSN .50-13X1.75 G5 ZCC		2
8	AGP06500705	NUT-PUSH, .50		2
9	AGP06500840	NUT,LK-CTR-FLG .31-18 GF ZCC		2
10	AGP06500902	NUT-LK-CTR-FLG .500-13 GG ZCC		2
11	AGP07400122	SCR-TAP .25-20X.50 HWH ZCC		2
12	AGP303012451	PLATE, FAN GUARD CE (BLACK)		1

AGU915344 Front & Rear Wheels - 34"

SERVICE PARTS:
07100716 - TIRE, 18X6.50-8

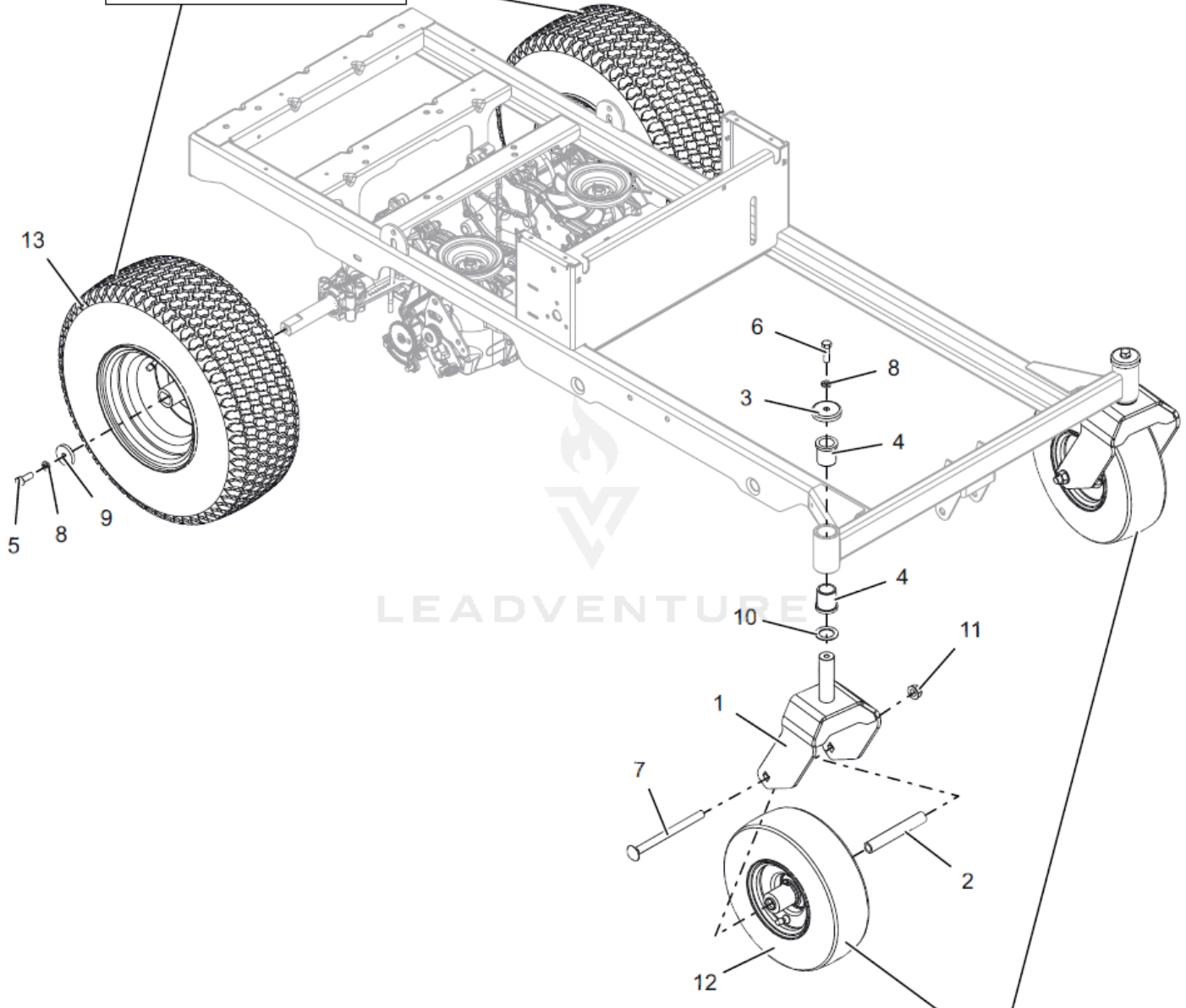

(2) 05400726 - BRG, .75 ID X 1.375 OD
(1) 07101235 - TIRE, 11 X 4-5 TURF TREAD

Rendered by LeadVenture, Inc.

AGU915344 Front & Rear Wheels - 34"

Ref Number	Part Number	Part Description	Context Notes	Quantity
1	AGP05266153	WLDMT, CASTER FORK-X		2
2	AGP00278500	SPACER, ROLLED WHEEL		2
3	AGP05290100	SHIELD, AXLE BEARING		2
4	AGP05500934	BSHG-FLG 1.00X1.25X1.50X1.50		4
5	AGP05901721	BLT, HEX .38-16X1.00 G8ZCCEP30		2
6	AGP05901724	BLT, HEX .38-16X1.25 G5 ZCC		2
7	AGP06200319	BLT, RHSN .50-13X6.50 G5 ZCC		2
8	AGP06300116	WSHR,LK-REG .375X.094 ZCC		4
9	AGP06401110	WSHR, FLT .406X1.50X.245 ZCC		2
10	AGP06416600	WSHR-HRD-THRS 1.007X1.542X.062		2
11	AGP06500902	NUT-LK-CTR-FLG .500-13 GG ZCC		2
12	AGP07101127	ASM, WHL/TIRE 11X4.00-5		2
13	AGP07101129	ASM, WHL/TIRE 18X6.50-8 DHUB		2
14	AGP07100716	TYRE, 18X6.5-8	SERVICE PART	1
15	AGP05434900	BRG-BALL .752X1.380X.500	SERVICE PART	2
16	AGP07101235	TIRE, 11X4-5 TURF TREAD	SERVICE PART	1

AGU915344 Fuel System

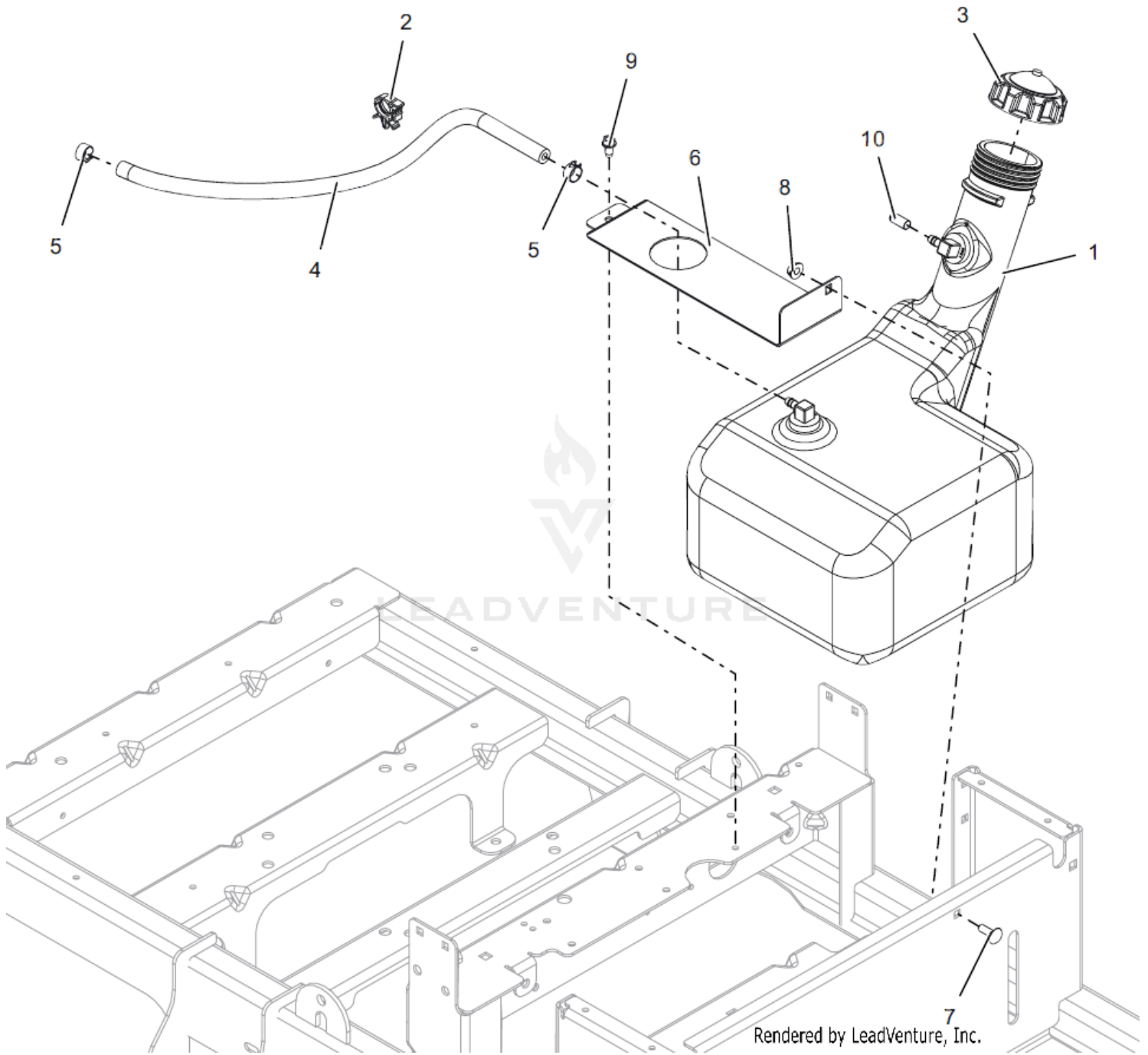

AGU915344 Fuel System

Ref Number	Part Number	Part Description	Context Notes	Quantity
1	AGP05244700	ASM, FUEL TANK-ZOOM		1
2	AGP00390100	WIRE CLIP		1
3	AGP01538400	FUEL CAP		1
4	AGP03278100	1 INCH OF HOSE, .25 LOW-PERM BULK GAS		1
5	AGP03278800	CLAMP, FUEL LINE		2
6	AGP03771451	BRKT, TANK STRAP		1
7	AGP06200307	BLT, RHSN .25-20X.750 G5 ZCC		1
8	AGP06500821	NUT-LK-CTR-FLG .25-20 ZC120		1
9	AGP07400122	SCR-TAP .25-20X.50 HWH ZCC		1
10	AGP143800100	VINYL CAP, 7.5X19MM BLACK		1

AGU915344 Idlers & Sheaves - 34"

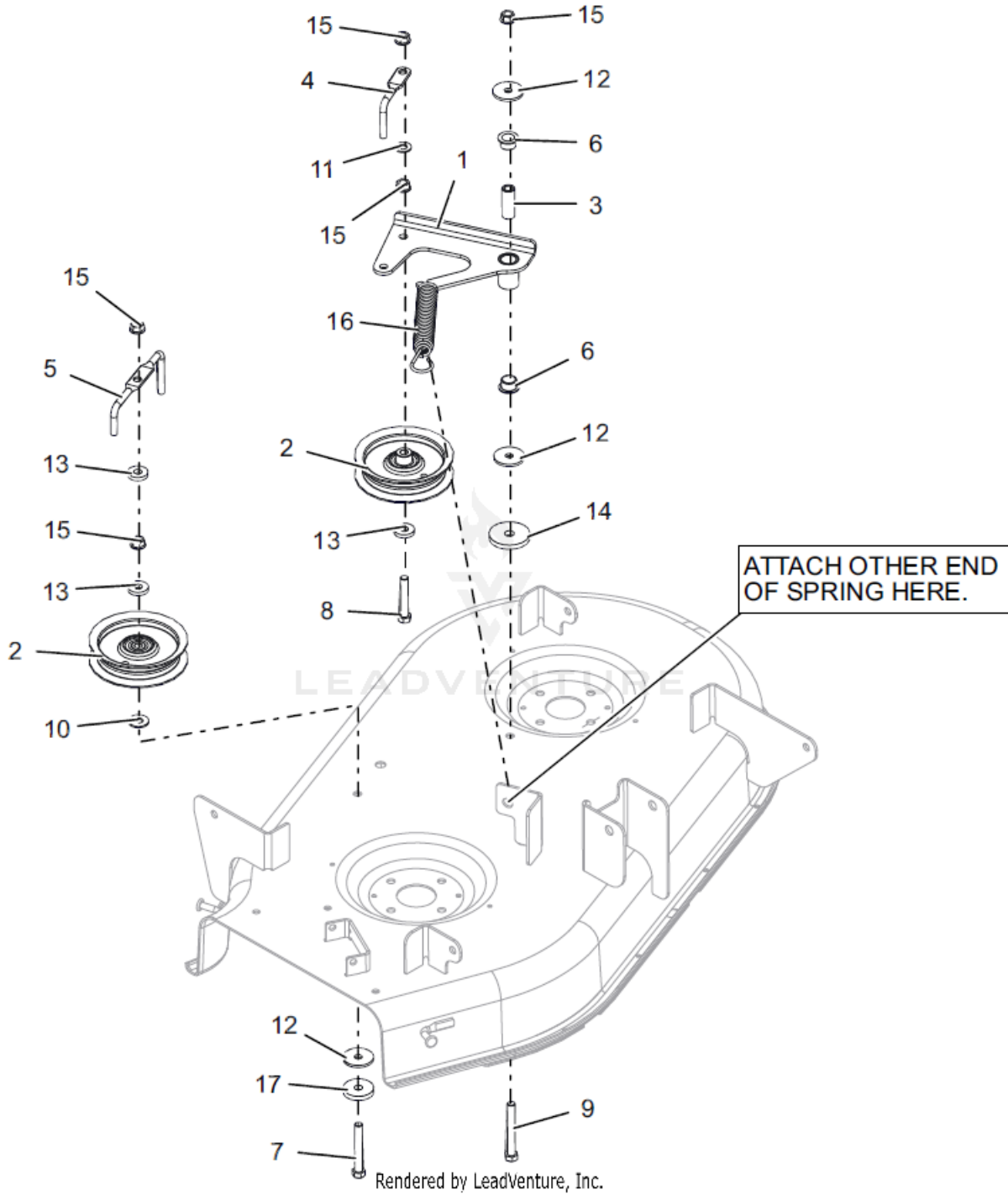

AGU915344 Idlers & Sheaves - 34"

Ref Number	Part Number	Part Description	Context Notes	Quantity
1	AGP04430853	WLDMT, IDLER ARM (RED)		1
2	AGP07350100	IDLER, FLAT - 4.06" X .75"		2
3	AGP03763400	SPACER, .375IDX.625ODX1.66 PM		1
4	AGP03828800	WIREFORM-BELT FINGER		1
5	AGP03974100	BELT FINGER		1
6	AGP05500907	BSHG-FLG, .625X.750X.500X1.00		2
7	AGP05901611	BLT, HEX .38-16X2.75 G5 ZCC		1
8	AGP05901640	BLT,HEX .38-16X2.25 G5 ZCC		1
9	AGP05901814	BLT, HEX .38-16X3.00 G5 ZCC		1
10	AGP06401008	WSHR,FLT .438X1.00X.083 ZCC		1
11	AGP06401013	WSHR,FLT .406X.812X.065 ZCC		1
12	AGP06401106	WSHR, FLT .380X1.50X.125 ZCC		3
13	AGP06401108	WSHR, FLT .406X1.00X.188 ZCC		3
14	AGP06401111	WSHR, FLT .469X2.00X.250 ZCC		1
15	AGP06500901	NUT-LK-CTR-FLG .375-16 GF ZCC		5
16	AGP08320300	SG-TENS .135X.98X6.0 WLD 62		1
17	AGP06401110	WSHR, FLT .406X1.50X.245 ZCC		1

AGU915344 Muffler Guarding

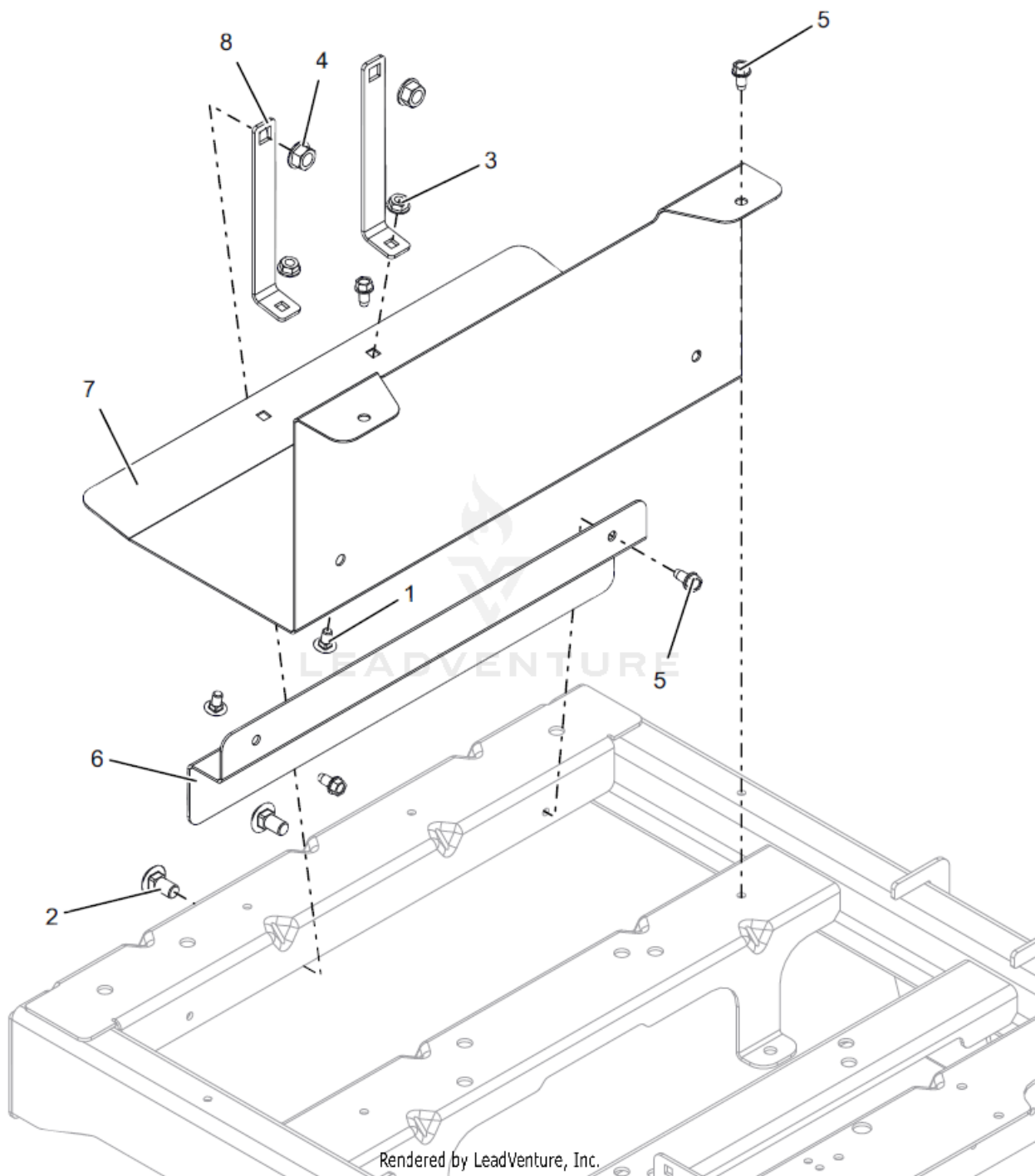

AGU915344 Muffler Guarding

Ref Number	Part Number	Part Description	Context Notes	Quantity
1	AGP06200306	BLT, RHSN .25-20X.500 G5 ZCC		2
2	AGP06200312	BLT, RHSN .38-16X.750 G5 ZCC		2
3	AGP06500821	NUT-LK-CTR-FLG .25-20 ZC120		2
4	AGP06500901	NUT-LK-CTR-FLG .375-16 GF ZCC		2
5	AGP07400122	SCR-TAP .25-20X.50 HWH ZCC		4
6	AGP303012651	GUARD, EXHAUST EDGE CE (BLACK)		1
7	AGP303012751	SHIELD, MUFFLER ZT EDGE CE (BLACK)		1
8	AGP303012851	STRAP, MUFFLER EDGE CE		2

AGU915344 Parking Brake

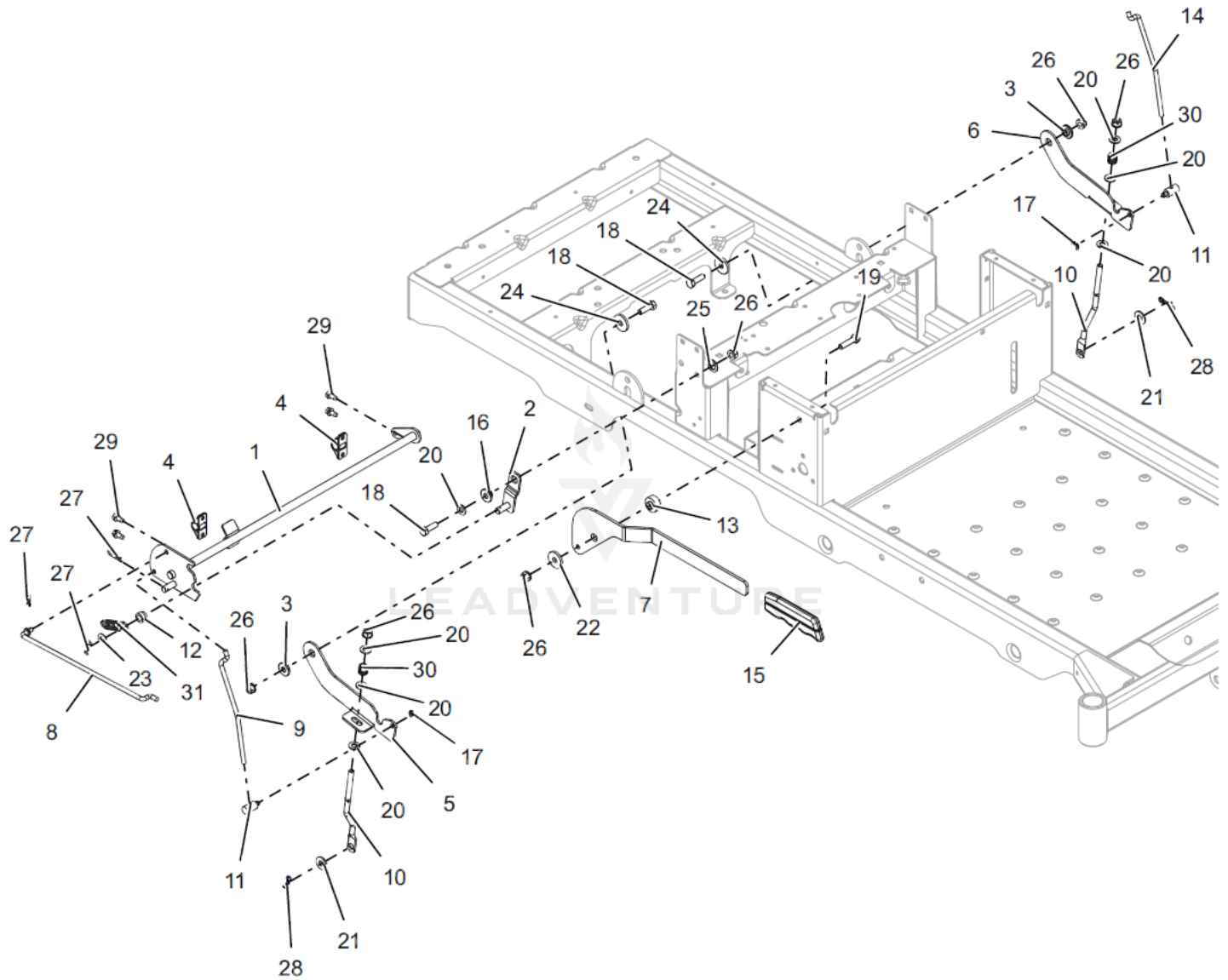

Rendered by LeadVenture, Inc.

AGU915344 Parking Brake

Ref Number	Part Number	Part Description	Context Notes	Quantity
1	AGP03761100	WELDMENT, BRAKE SHAFT		1
2	AGP03759200	WELDMENT,DETENT ARM		1
3	AGP01305900	BSHG, FLG .325X.499X.26X.88		2
4	AGP03757501	BUSHING-.50 CLAMP BLOCK MOLDED		2
5	AGP03758900	LATCH,RH NETURAL		1
6	AGP03759000	LATCH,LH NETURAL		1
7	AGP03759151	HANDLE, PARKING BRAKE		1
8	AGP03759400	LINK, BRAKE HANDLE		1
9	AGP03759500	LINK, NEUTRAL RH		1
10	AGP03759600	LINK, BRAKE COG		2
11	AGP03764800	TRUNION, 1/4-20		2
12	AGP03764900	ROLLER		1
13	AGP03769400	SPCR,BRAKE .32X.49X.192X1.00		1
14	AGP03823300	LINK, NEUTRAL LH		1
15	AGP05097200	GRIP, PARKING		1
16	AGP05514800	BSHG-FLG .32X.500X.344X.880		1
17	AGP05700125	RG-RTNG-EXT .250X.025		2
18	AGP05901701	BLT,HEX .31-18X1.00 G5 ZCC		3
19	AGP05901803	BLT, HEX .31-18X1.25 G5 ZCC		1
20	AGP06401017	WSHR,FLT .344X.688X.065 ZCC		7
21	AGP06401023	WSHR,FLT .375X.875X.083 ZCC		2
22	AGP06401104	WSHR, FLT .340X1.125X.135 ZCC		1
23	AGP06401107	WSHR, FLT .385X.745X.030 ZCC		1
24	AGP06401104	WSHR, FLT .340X1.125X.135 ZCC		2
25	AGP06401114	WSHR, FLT .520X.827X.062 ZCC		1
26	AGP06500840	NUT,LK-CTR-FLG .31-18 GF ZCC		6
27	AGP06700222	PIN, HAIR #213 .08X1.19 ZCC		3
28	AGP06700229	PIN, BOWTIE #72 ZCC		2

Ref Number	Part Number	Part Description	Context Notes	Quantity
29	AGP07400122	SCR-TAP .25-20X.50 HWH ZCC		4
30	AGP08300028	SPRING, COMPRESSION		2
31	AGP08326700	SG-TENS .072X.565X1.87		1

AGU915344 Rear Wrap & Engine Guards

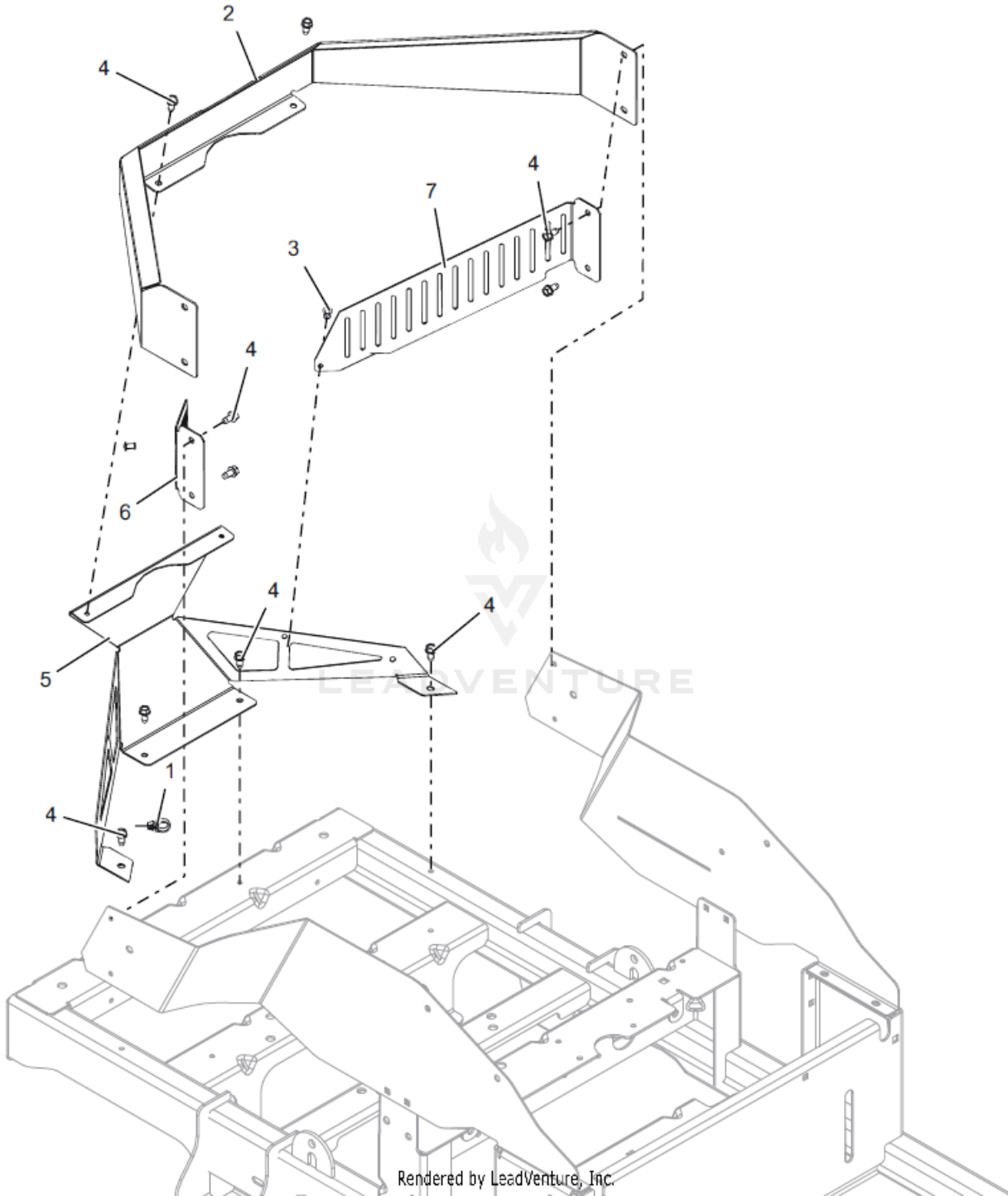

Rendered by LeadVenture, Inc.

AGU915344 Rear Wrap & Engine Guards

Ref Number	Part Number	Part Description	Context Notes	Quantity
1	AGP00367900	ROUTING CLIP (1/2" ID)		1
2	AGP05287800	WRAP, REAR - TOP		1
3	AGP06815700	RVT .187X.575 DOME AL BLACK		2
4	AGP07400122	SCR-TAP .25-20X.50 HWH ZCC		10
5	AGP303012551	WRAP, REAR EDGE CE (BLACK)		1
6	AGP303012951	SHIELD, LH ENGINE GUARD EDGE CE (BLACK)		1
7	AGP303013151	SHIELD, RH ENGINE GUARD EDGE CE (BLACK)		1

AGU915344 Seat & Seat Support

SERVICE PARTS:
71508400 - KIT, ARM REST W/HARDWARE
02754100 - SWITCH, SEAT
21572700 - KIT, ARM REST LH ASSY
21572800 - KIT, ARM REST RH ASSY
21568600 - POLY PAD

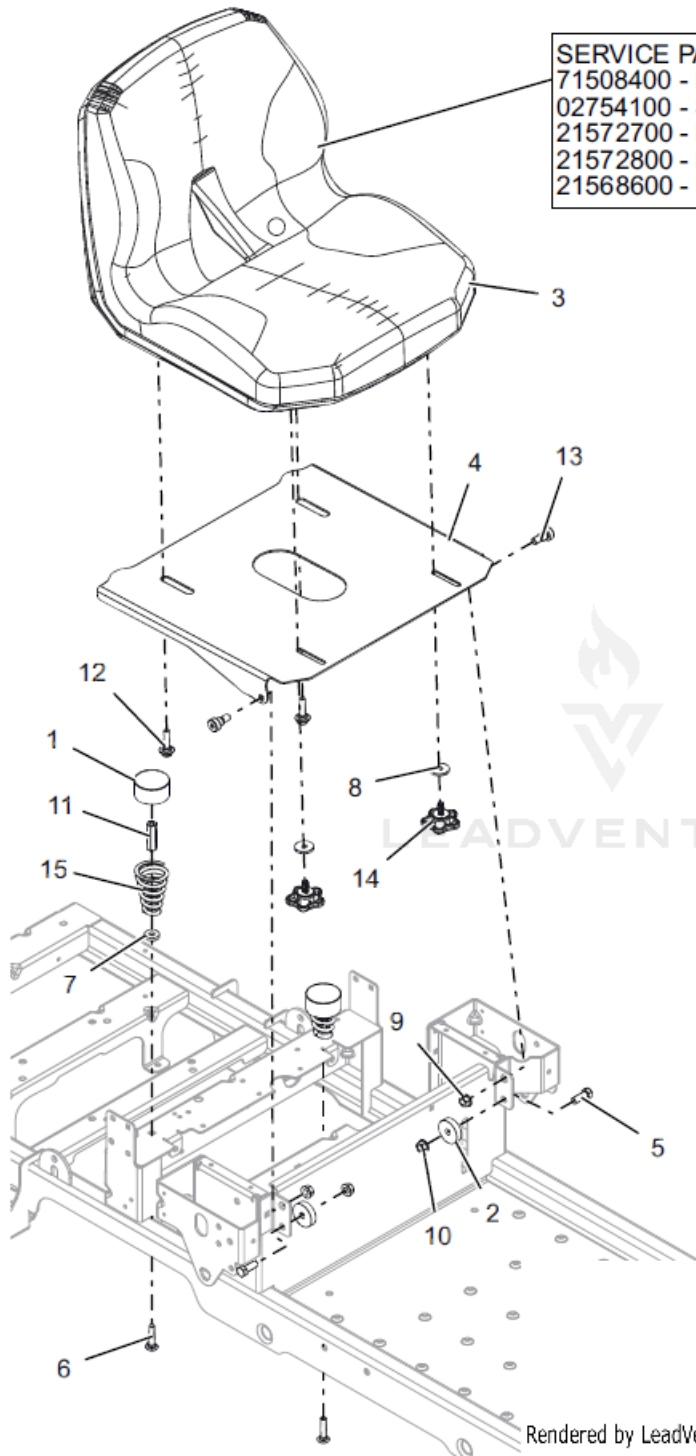

Rendered by LeadVen:ure, Inc.

AGU915344 Seat & Seat Support

Ref Number	Part Number	Part Description	Context Notes	Quantity
1	AGP00337700	HUB CAP		2
2	AGP01594000	SPACER, .39 X 1.50 X .380		2
3	AGP05286100	SEAT, EDGE 2020		1
4	AGP05289253	PLATE, SEAT (RED)		1
5	AGP05901711	BLT,HEX .375-16X1 GR5 ZC120		2
6	AGP06200233	BLT,RHSN .31-18X1.50 G5 ZCC		2
7	AGP06401103	WSHR, FLT .328X.870X.179 ZCC		2
8	AGP06401104	WSHR, FLT .340X1.125X.135 ZCC		2
9	AGP06500822	NUT-LK-TOP-FLG .38-16 ZC120		2
10	AGP06500901	NUT-LK-CTR-FLG .375-16 GF ZCC		2
11	AGP06500927	NUT, COUPLING .31-18X1.75 ZCC		2
12	AGP07001929	BLT, SHLDR .31-18 X .175		2
13	AGP07056500	BLT-SHLDR .38-16X.38 SKH		2
14	AGP07500226	KNOB, WING STUDDER		2
15	AGP08300021	SPRING, SEAT		2
16	AGP71508400	KIT, ARM REST W/ HARDWARE	SERVICE PART	1
17	AGP02754100	SWITCH- SNAP MTG N.O.	SERVICE PART	1
18	AGP21572700	KIT, ARM REST LH ASSY - PADDED	SERVICE PART	1
19	AGP21572800	KIT, ARM REST RH ASSY - PADDED	SERVICE PART	1
20	AGP21568600	POLY PAD	SERVICE PART	1

AGU915344 Steering Controls

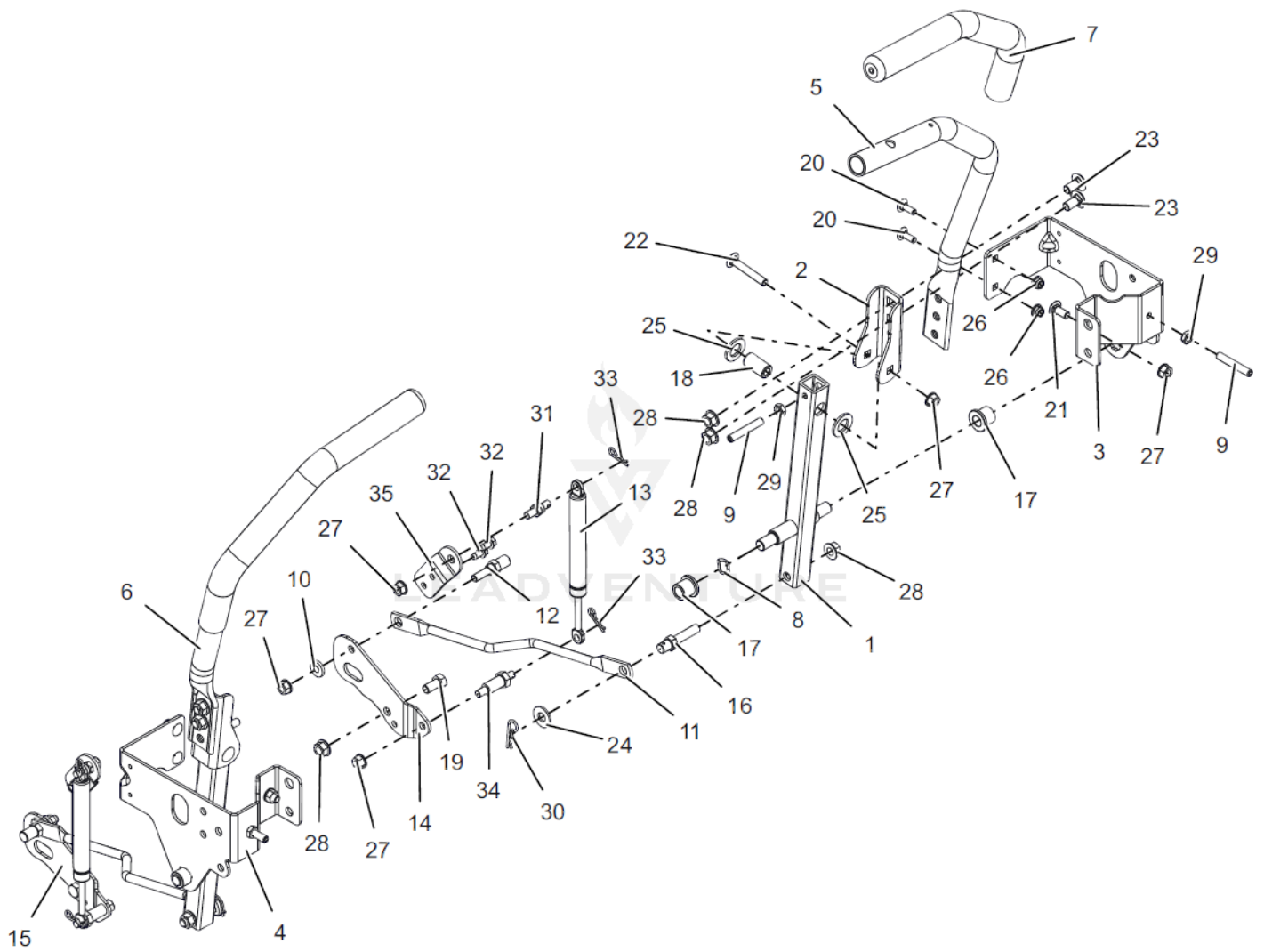

Rendered by LeadVenture, Inc.

AGU915344 Steering Controls

Ref Number	Part Number	Part Description	Context Notes	Quantity
1	AGP05286851	WLDMT, LOWER CONTROL ARM (BLACK)		2
2	AGP05281951	ARM, CONTROL-UPPER (BLACK)		2
3	AGP05288151	BRKT, SPEED ADJ/SEAT PIVOT-LH (BLACK)		1
4	AGP05288251	BRKT, SPEED ADJ/SEAT PIVOT-RH (BLACK)		1
5	AGP09161651	WLDMT, CONTROL HANDLE -LH (BLACK)		1
6	AGP09161751	WLDMT, CONTROL HANDLE - RH (BLACK)		1
7	AGP04257400	GRIP, HANDLEBAR 15" FOAM		2
8	AGP00325400	WAVE WASHER .531X.781X.125FH		2
9	AGP06100301	SCR-SET, .312-18X2.000 SS		4
10	AGP04147200	BSHG-FLG .316X.430X.225X.750		2
11	AGP05282400	LINKAGE, STEERING		2
12	AGP05282500	STUD, STEERING LINK-REAR		2
13	AGP05160400	DAMPER, STRAIGHT MOUNT		2
14	AGP03759351	PLATE, DAMPER RH		1
15	AGP03766000	PLATE, DAMPER		1
16	AGP05288400	STUD, STEERING LINK -FRONT		2
17	AGP05501001	BHSG-FLG .500X.750X.750X.125		4
18	AGP05501411	BSHG, -SLV .342 X .627 X 1.171		2
19	AGP05901702	BLT,HEX .38-16X.75 G5 ZCC		2
20	AGP06200307	BLT, RHSN .25-20X.750 G5 ZCC		4
21	AGP06200309	BLT, RHSSN.31-18X.750 G5 ZCC		2
22	AGP06200431	BLT, RHSSN .31-18X2.00 G5 ZCC		2
23	AGP06200432	BTL,RHSSN .375-16 X 0.75 G5 FPB		4
24	AGP06401008	WSHR,FLT .438X1.00X.083 ZCC		2
25	AGP06401130	WSHR, FRICTION		4
26	AGP06500813	NUT,NYL-FLG .25-20 GF ZCC		4

Ref Number	Part Number	Part Description	Context Notes	Quantity
27	AGP06500840	NUT,LK-CTR-FLG .31-18 GF ZCC		10
28	AGP06500901	NUT-LK-CTR-FLG .375-16 GF ZCC		8
29	AGP06500909	NUT-JAM .312-18 G2 ZCC		4
30	AGP06700219	PIN, HAIR .09 X 1.50 ZCC		2
31	AGP05171400	COUPLER, DAMPER MOUNT		2
32	AGP07400122	SCR-TAP .25-20X.50 HWH ZCC		4
33	AGP06700222	PIN, HAIR #213 .08X1.19 ZCC		4
34	AGP09157100	COUPLER, DAMPER MOUNT (LOWER)		2
35	AGP09155951	PLATE, DAMPER TOP MOUNTING (BLACK)		2

AGU915344 Transaxles & Idler Pulley - 34"

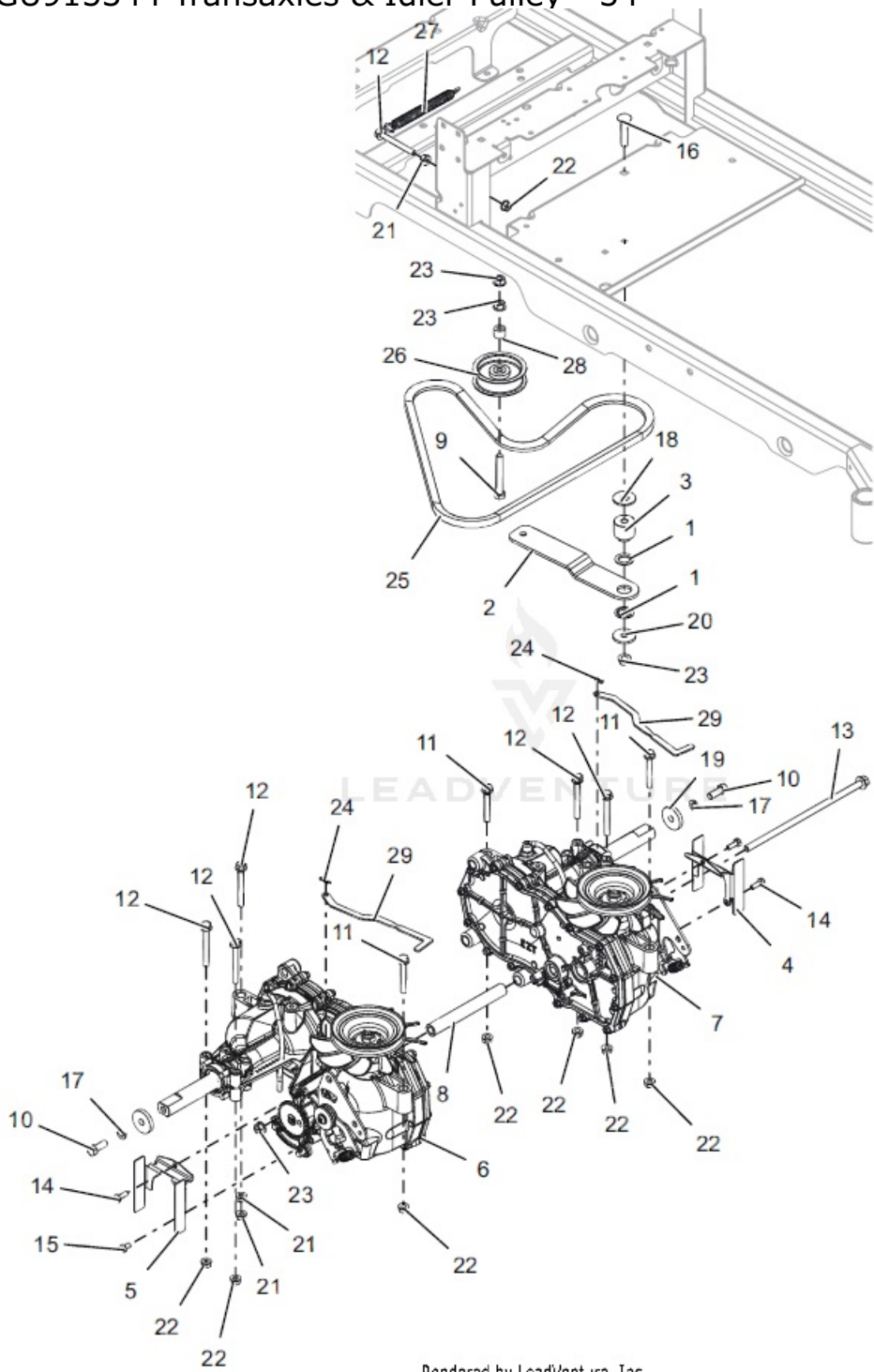

Rendered by LeadVenture, Inc.

AGU915344 Transaxles & Idler Pulley - 34"

Ref Number	Part Number	Part Description	Context Notes	Quantity
1	AGP03960700	BUSHING, IDLER ARM		2
2	AGP03961000	IDLER ARM, GROUND DRIVE		1
3	AGP03961100	SPACER, GROUND DRIVE IDLER		1
4	AGP05091251	GUARD, PARKING BRAKE RH (BLACK)		1
5	AGP05092551	GUARD, PARKING BRAKE LH (BLACK)		1
6	AGP05172700	TRANSAXLE EZT D-SHFT SHORT		1
7	AGP05172800	TRANSAXLE EZT D-SHFT SHORT		1
8	AGP05281800	SPCR, TRANSAXLE .438 ID X .750 OD X 8.18		1
9	AGP05901611	BLT, HEX .38-16X2.75 G5 ZCC		1
10	AGP05901721	BLT, HEX .38-16X1.00 G8ZCCEP30		2
11	AGP05901910	BLT,HEX-FLG .31-18X2.25 G5 ZCC		3
12	AGP05901911	BLT,HEX-FLG .31-18X2.75 G5 ZCC		6
13	AGP05902032	BLT, HEX-FLG 0.375-16X9.75 GR5 ZC120		1
14	AGP05946800	@BLT-HEX .25-20X.75 GR5 YWZC		3
15	AGP05947900	BOLT, HEX 0.25-20X0.5 GR5		1
16	AGP06200323	BLT,RHSSN.375-16X2.00 G5 ZCC		1
17	AGP06300116	WSHR,LK-REG .375X.094 ZCC		2
18	AGP06401012	WSHR,FLT .563X1.375X.109 ZCC		1
19	AGP06401110	WSHR, FLT .406X1.50X.245 ZCC		2
20	AGP06401121	WSHR,FLT .406X1.375X.135 ZCC		1

Ref Number	Part Number	Part Description	Context Notes	Quantity
21	AGP06500815	NUT,SPNLK-FLG .31-18 G5 ZCC		3
22	AGP06500840	NUT,LK-CTR-FLG .31-18 GF ZCC		8
23	AGP06500901	NUT-LK-CTR-FLG .375-16 GF ZCC		4
24	AGP06700221	PIN-HAIR INT .06X.18X.77		2
25	AGP07200010	V-BELT, HA-RAW EDGE		1
26	AGP07300221	PULLEY, ENGINE CLUTCH 03608		1
27	AGP08300512	SPRING, EXTENSION		1
28	AGP08553700	BSHG-SLV .391X.688X.52 PM		1
29	AGP09160551	BRKT, VALVE DUMP (BLACK)		2

AGU915344 Wiring Diagram

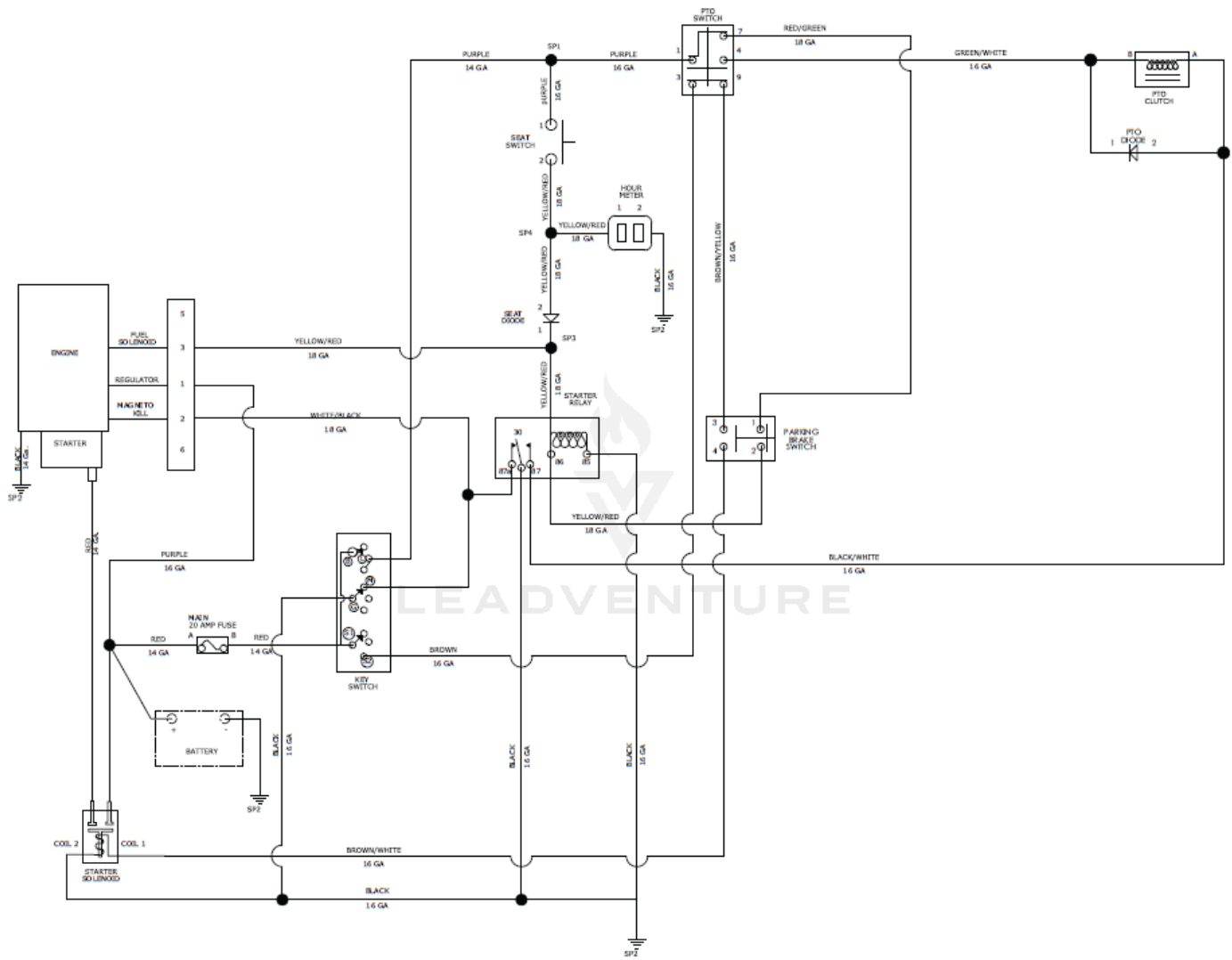

Rendered by LeadVenture, Inc.

AGU915344 Wiring Diagram

Ref Number	Part Number	Part Description	Context Notes	Quantity
-------------------	--------------------	-------------------------	----------------------	-----------------