

ZT HD 48 [AGU991269]

TABLE OF CONTENTS

AGU991269 Unit	3
AGU991269 Anti-Scalp Wheels - 44" & 48"	5
AGU991269 Belt Covers - 48"	7
AGU991269 Clutch	9
AGU991269 Control Panel	11
AGU991269 Controls	13
AGU991269 Decals - Safety	16
AGU991269 Decals - Style 48"	18
AGU991269 Deck Lift - LH	20
AGU991269 Deck Lift - RH	22
AGU991269 Deck, Belts, Blades & Spindles - 48"	25
AGU991269 Discharge Chute - 44" & 48"	27
AGU991269 Electrical	29
AGU991269 Engine - Kawasaki FR691V	32
AGU991269 Engine Guard & Fenders	34
AGU991269 Frame - 44", 48" & 52"	37
AGU991269 Front Caster Wheels	39
AGU991269 Fuel System	41
AGU991269 Heat Shield	43
AGU991269 Idlers & Sheaves - 44" & 48"	45
AGU991269 Parking Brake	48
AGU991269 Rear Tyres & Transaxles - 48"	51
AGU991269 Seat	53
AGU991269 Transaxle Drive	56
AGU991269 Wiring Diagram	58



Rendered by LeadVenture, Inc.

AGU991269 Unit

Ref Number	Part Number	Part Description	Context Notes	Quantity
1	AGU991269	ZT HD 48 - 23HP KAWASAKI FR691V		1

AGU991269 Anti-Scalp Wheels - 44" & 48"

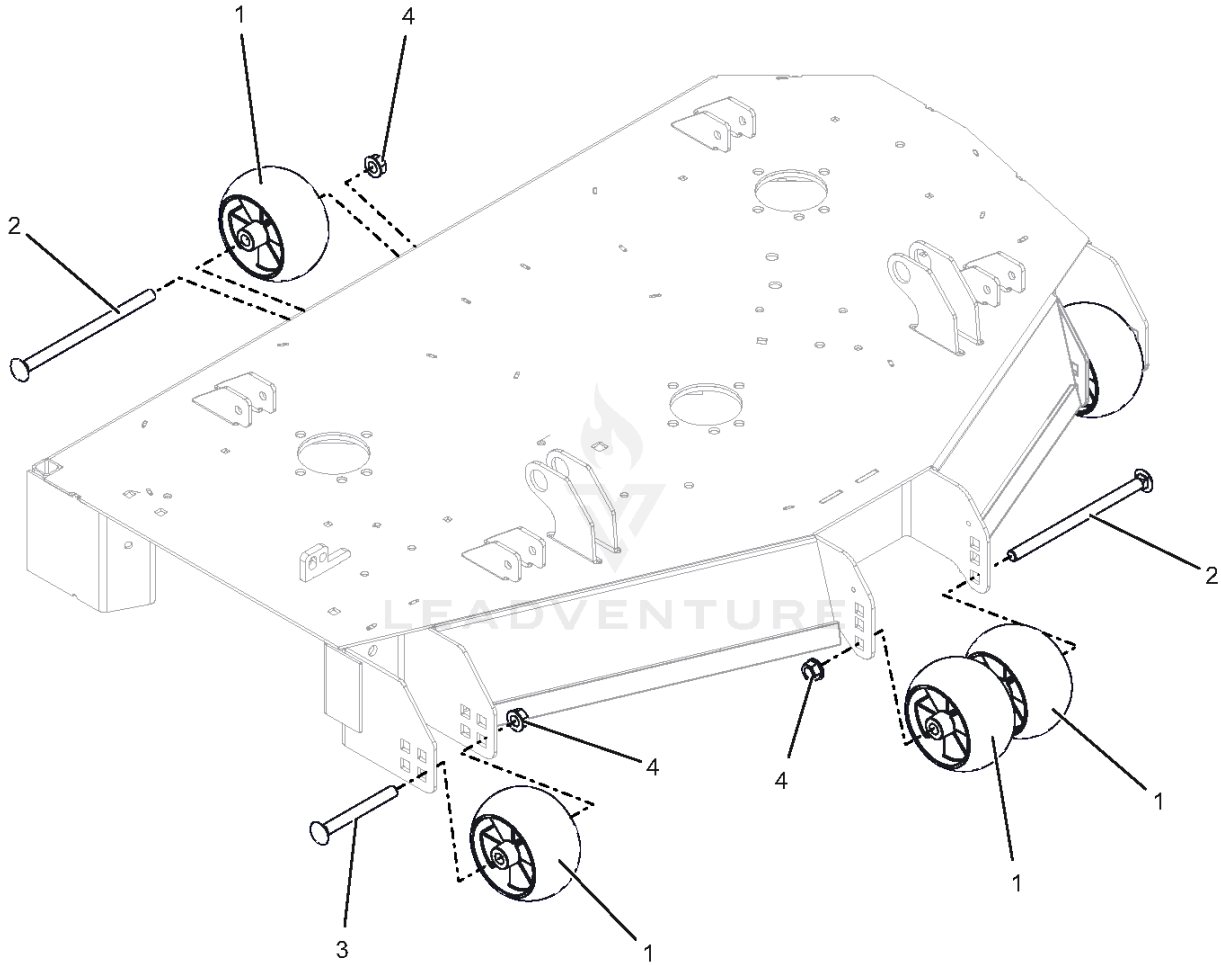

Rendered by LeadVenture, Inc.

AGU991269 Anti-Scalp Wheels - 44" & 48"

Ref Number	Part Number	Part Description	Context Notes	Quantity
1	AGP05268800	WHEEL, ANTI SCALP - 5X3 CTR W/RIBS		5
2	AGP06200506	BLT,RHSN .50-13X8.00 G5 ZCC NS		2
4	AGP06500902	NUT-LK-CTR-FLG .500-13 GG ZCC		4

AGU991269 Belt Covers - 48"

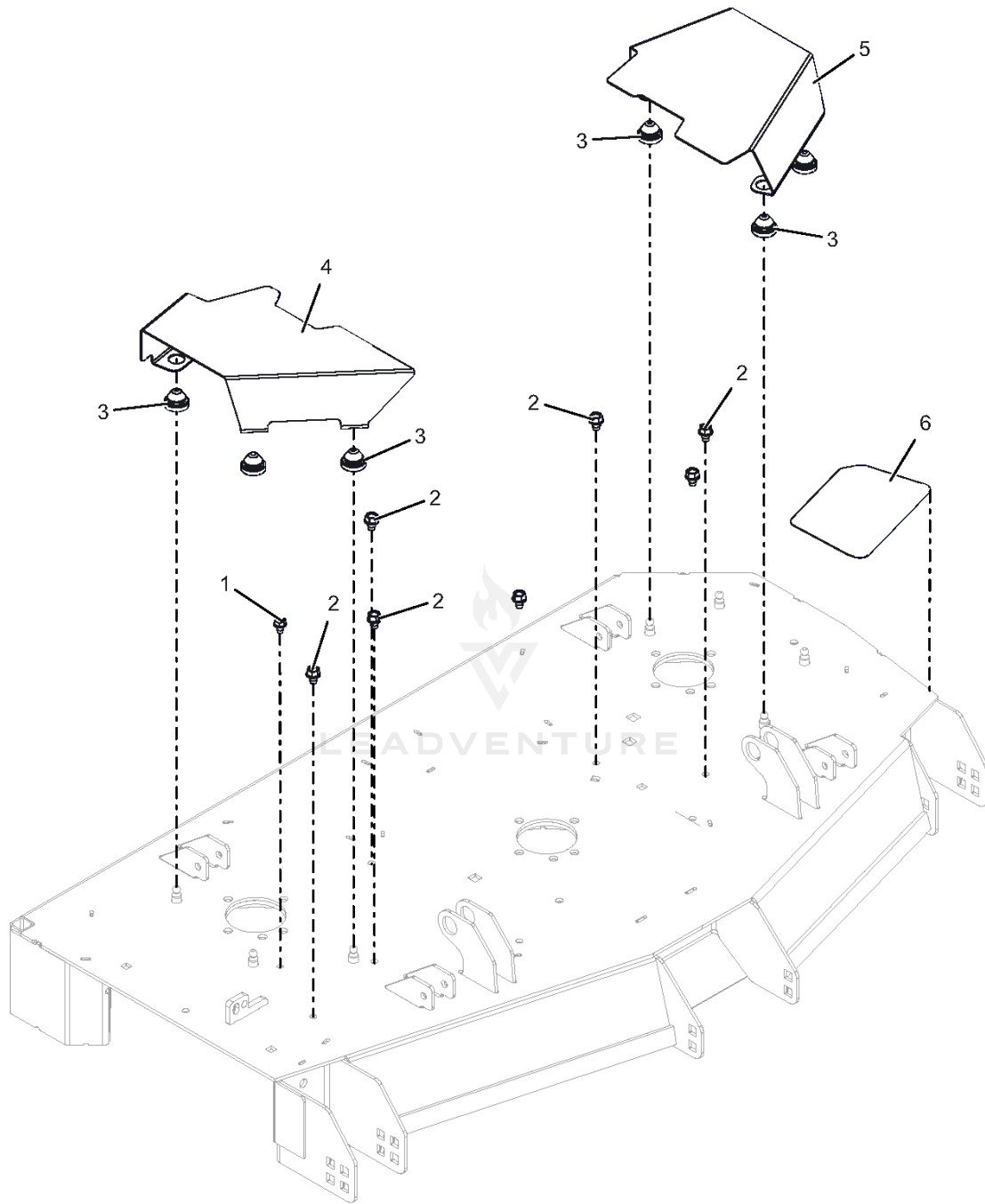

Rendered by LeadVenture, Inc.

AGU991269 Belt Covers - 48"

Ref Number	Part Number	Part Description	Context Notes	Quantity
1	AGP07400124	SCR,TAP .312-18X.50 HWH TR ZCC		1
2	AGP07400126	SCR,TAP .375-16X.50 HWH TR ZCC		7
3	AGP07500429	COUPLING, RUBBER PUSH- IN		7
4	AGP09458653	COVER- BELT 48" RIGHT		0
5	AGP09458753	COVER- BELT 48" LEFT		0
6	AGP09461300	GRIP, STEP ANTI SKID HD XF3		0

AGU991269 Clutch

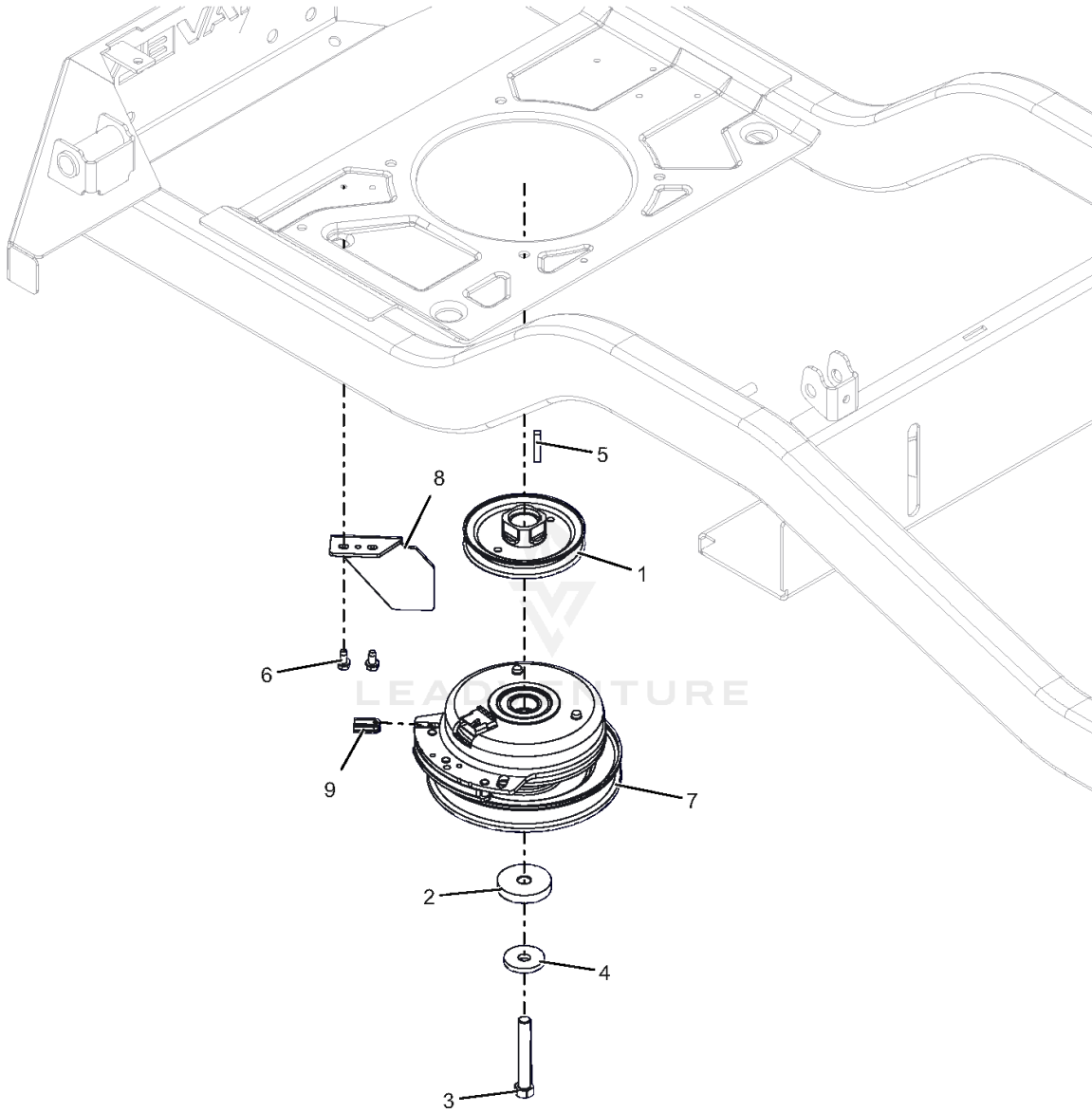

Rendered by LeadVenture, Inc.

AGU991269 Clutch

Ref Number	Part Number	Part Description	Context Notes	Quantity
1	AGP07346400	PULLEY, 4.50 OD X 1.003 ENGINE		1
2	AGP05501240	SPACER, .474/.459X2.00X.350		1
3	AGP05901819	BLT, HEX 0.4375-20X3 G8 ZCC NT		1
4	AGP06400936	WASHER, 7/16" SPRING DISK		1
5	AGP06603400	KEY-SQ .25 X 1.25 X .25 SAE		1
6	AGP07400122	SCR-TAP .25-20X.50 HWH ZCC		2
7	AGP09444200	CLUTCH, WARNER 1.00 HD, PTZ		1
8	AGP09449951	BRKT, CLUTCH		1
9	AGP30145600	BSHG, CLUTCH		1

AGU991269 Control Panel

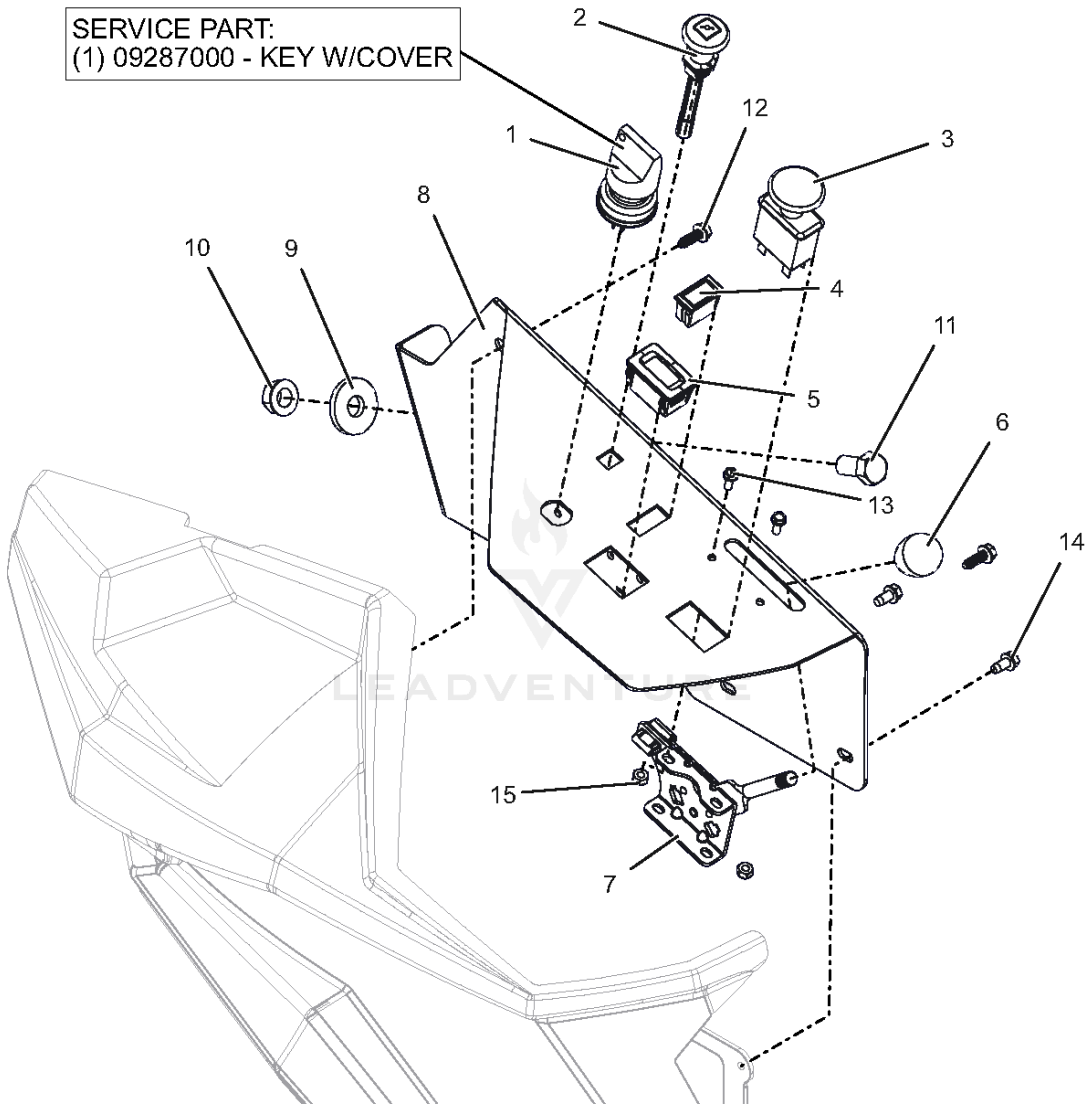

Rendered by LeadVenture, Inc.

AGU991269 Control Panel

Ref Number	Part Number	Part Description	Context Notes	Quantity
1	AGP04331600	SWITCH, IGNITION		1
2	AGP06900621	CABLE - CHOKE, SNAP-IN		1
3	AGP01545600	SWITCH, CLUTCH		1
4	AGP09003300	SWITCH,BLANK		1
5	AGP05254800	HOUR METER		1
6	AGP07500132	KNOB-CONTROL-BLACK .38-16X.50		1
7	AGP06900619	CABLE, PRO THROTTLE CONTROL		1
8	AGP09189053	PANEL, HD CONTROL (RED)		1
9	AGP06401225	WASHER- FLT .562X1.50X.187 ZCC		1
10	AGP06500907	NUT-LK-TOP-FLG .500-13 GF ZCC		1
11	AGP05901715	BLT, HEX .50-13X1.00 G5 ZCC		1
12	AGP06100231	SCR, PLASTITE-HWH 0.25 X 0.75 ZC120		2
13	AGP05901825	BLT, HWH #10-24X.50 ZCC		2
14	AGP07400122	SCR-TAP .25-20X.50 HWH ZCC		2
15	AGP06500915	NUT-LK-NYL #10-24 G2 ZCC		2
16	AGP09287000	KEY, W/ SHIELD	SERVICE PART	1

AGU991269 Controls

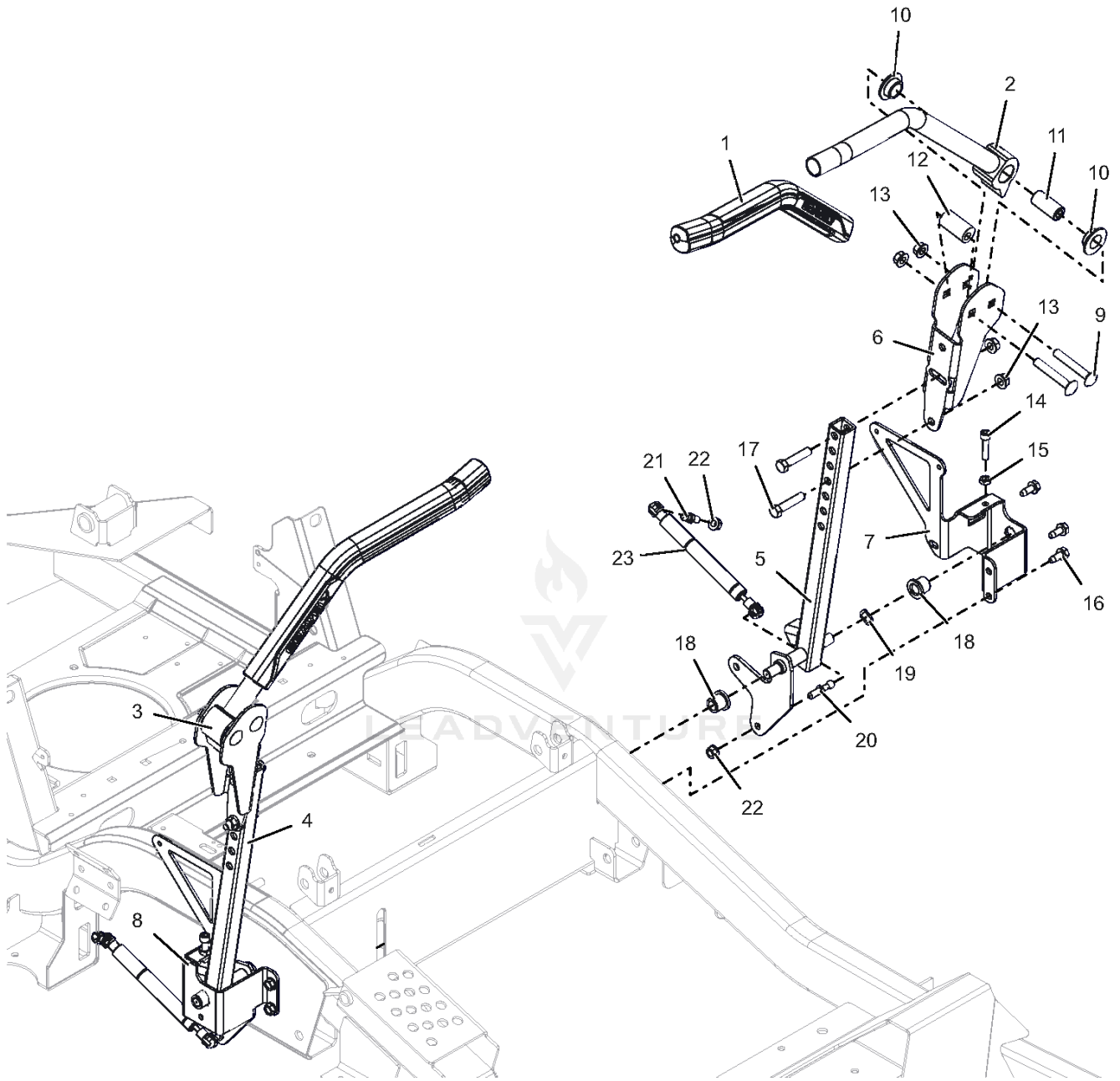

Rendered by LeadVenture, Inc.

AGU991269 Controls

Ref Number	Part Number	Part Description	Context Notes	Quantity
1	AGP05368700	GRIP, HANDLEBAR GRAVELY		2
2	AGP05261853	WLDMT, CONTROL HANDLE (RED)		1
3	AGP05262153	WLDMT, CONTROL HANDLE (RED)		1
4	AGP05243953	WLDMT, STEERING RH (RED)		1
5	AGP05244053	WLDMT, STEERING -LH (RED)		1
6	AGP05068753	BRKT, ADJ UPPER CONTROL ARM (RED)		2
7	AGP09189953	BRKT, STEERING ARM MOUNTING -LH (RED)		1
8	AGP09190053	BRKT, STEERING ARM MOUNTING- RH (RED)		1
9	AGP06200315	BLT, RHSSN.38-16X2.50 G5 ZCC		4
10	AGP05501517	BSHG, FLANGED .762 X 1.48 X .44 IGLIDER		4
11	AGP04413600	SPACER, STEERING ARM		2
12	AGP05501223	BSHG, ECCENTRIC.406X.875X1.625		2
13	AGP06500822	NUT-LK-TOP-FLG .38-16 ZC120		8
14	AGP05901826	SCR, SKH .312-18X1.25 GR8 ZC120		2
15	AGP06500909	NUT-JAM .312-18 G2 ZCC		2
16	AGP07400127	SCR,TAP .312-18X.75 HWH TR ZCC		6
17	AGP05901809	BLT, HEX .38-16X1.75 G5 ZCC		4
18	AGP05501001	BHSG-FLG .500X.750X.750X.125		4
19	AGP00325400	WAVE WASHER .531X.781X.125FH		2
20	AGP04097100	STUD-BALL-THREADED		2
21	AGP03652200	STUD- BALL		2

Ref Number	Part Number	Part Description	Context Notes	Quantity
22	AGP06500840	NUT,LK-CTR-FLG .31-18 GF ZCC		4
23	AGP09689700	DAMPER		2

AGU991269 Decals - Safety

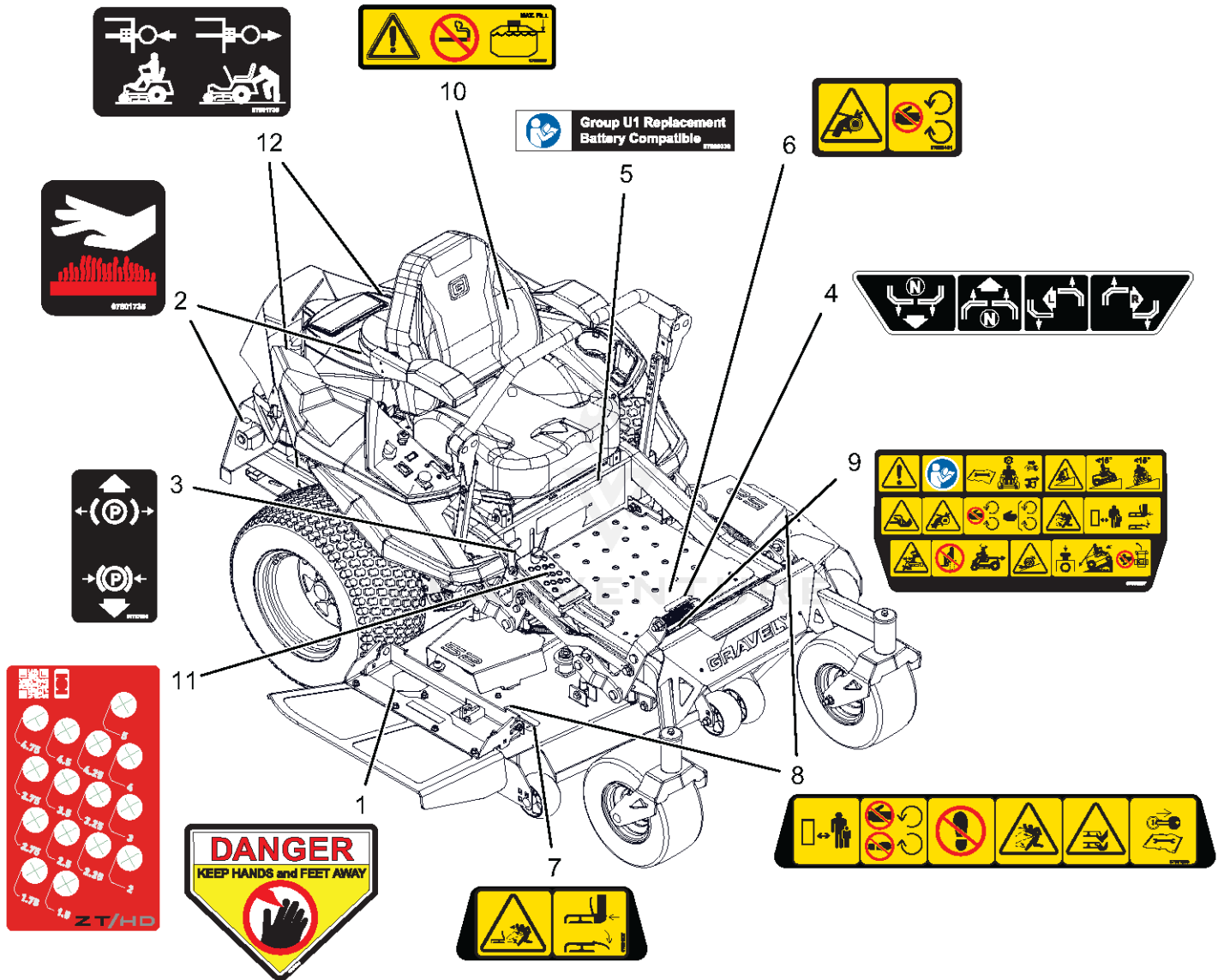

Rendered by LeadVenture, Inc.

AGU991269 Decals - Safety

Ref Number	Part Number	Part Description	Context Notes	Quantity
1	AGP02988100	DECAL, DANGER		1
2	AGP07801735	DECAL, SAFETY HOT SURFACE		2
3	AGP07757500	DECAL, PARKING BRAKE LEVER		1
4	AGP07801724	DECAL- INSTRUCTIONAL- STEERING		1
5	AGP07800336	DECAL, U1 BATTERY REPLACEMENT		1
6	AGP07800401	DECAL, SAFETY - GUARDING		1
7	AGP07801837	DECAL, SAFETY - DECK GUARDING		1
8	AGP07801836	DECAL, SAFETY - MOWER DECK		2
9	AGP07800537	DECAL, MAIN SAFETY		1
10	AGP07800820	DECAL, FUEL WARNING		1
11	AGP07801926	DECAL, ZT HD HOC		1
12	AGP07801736	DECAL, TRANSAXLE DISCONNECT		2

AGU991269 Decals - Style 48"

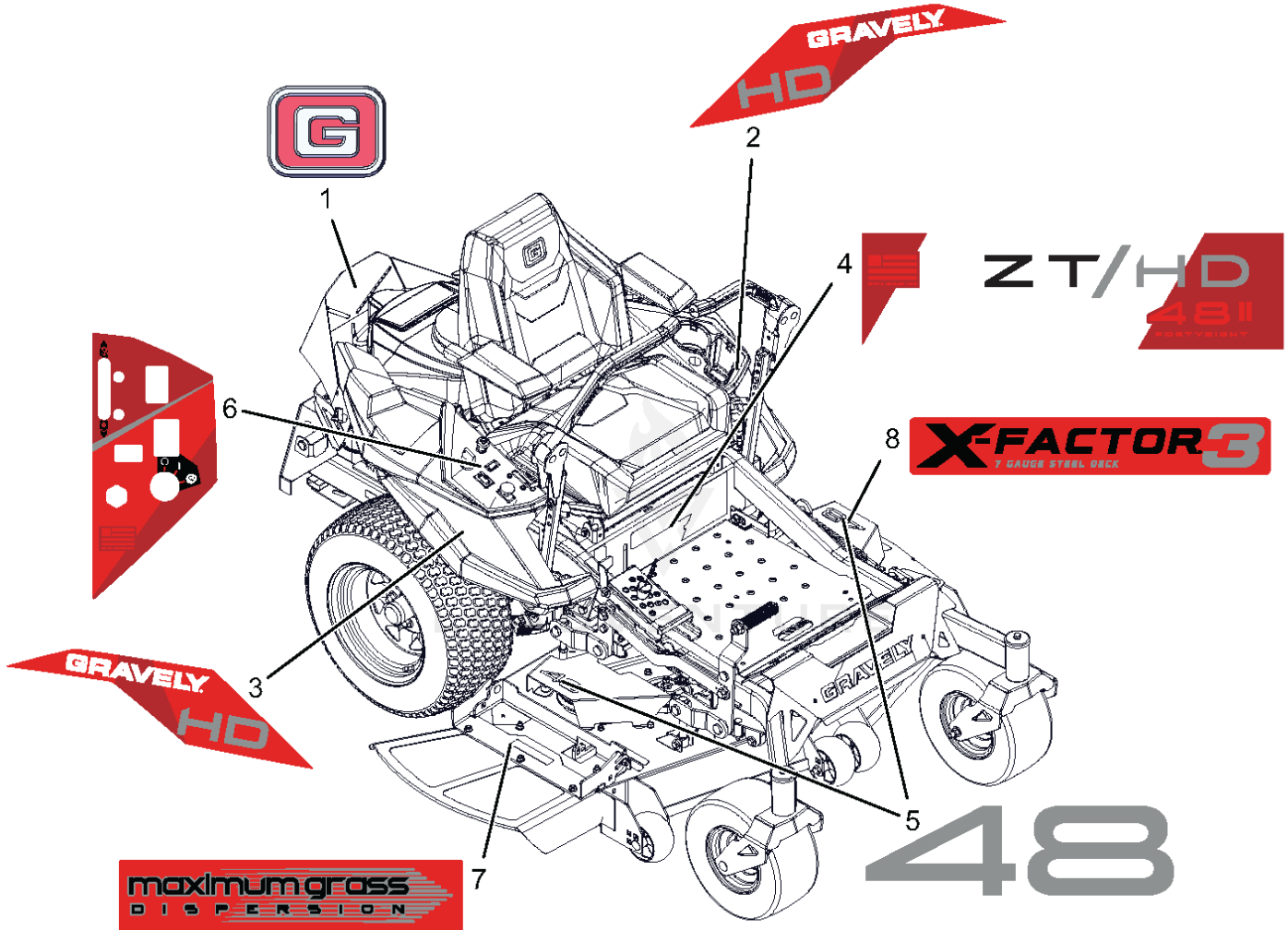

Rendered by LeadVenture, Inc.

AGU991269 Decals - Style 48"

Ref Number	Part Number	Part Description	Context Notes	Quantity
1	AGP07800534	DECAL, GRAVELY BRAND		1
2	AGP07801109	DECAL, FENDER LH - HD		1
3	AGP07801110	DECAL, FENDER RH - HD		1
4	AGP07801119	DECAL, ZT/HD - 48		1
5	AGP07801123	DECAL, DECK - 48		2
6	AGP07801126	DECAL, CONTROL PANEL		1
7	AGP07801229	DECAL, DECK - MAX GRASS		1
8	AGP07801232	DECAL, DECK - X-FACTOR 3		1

AGU991269 Deck Lift - LH

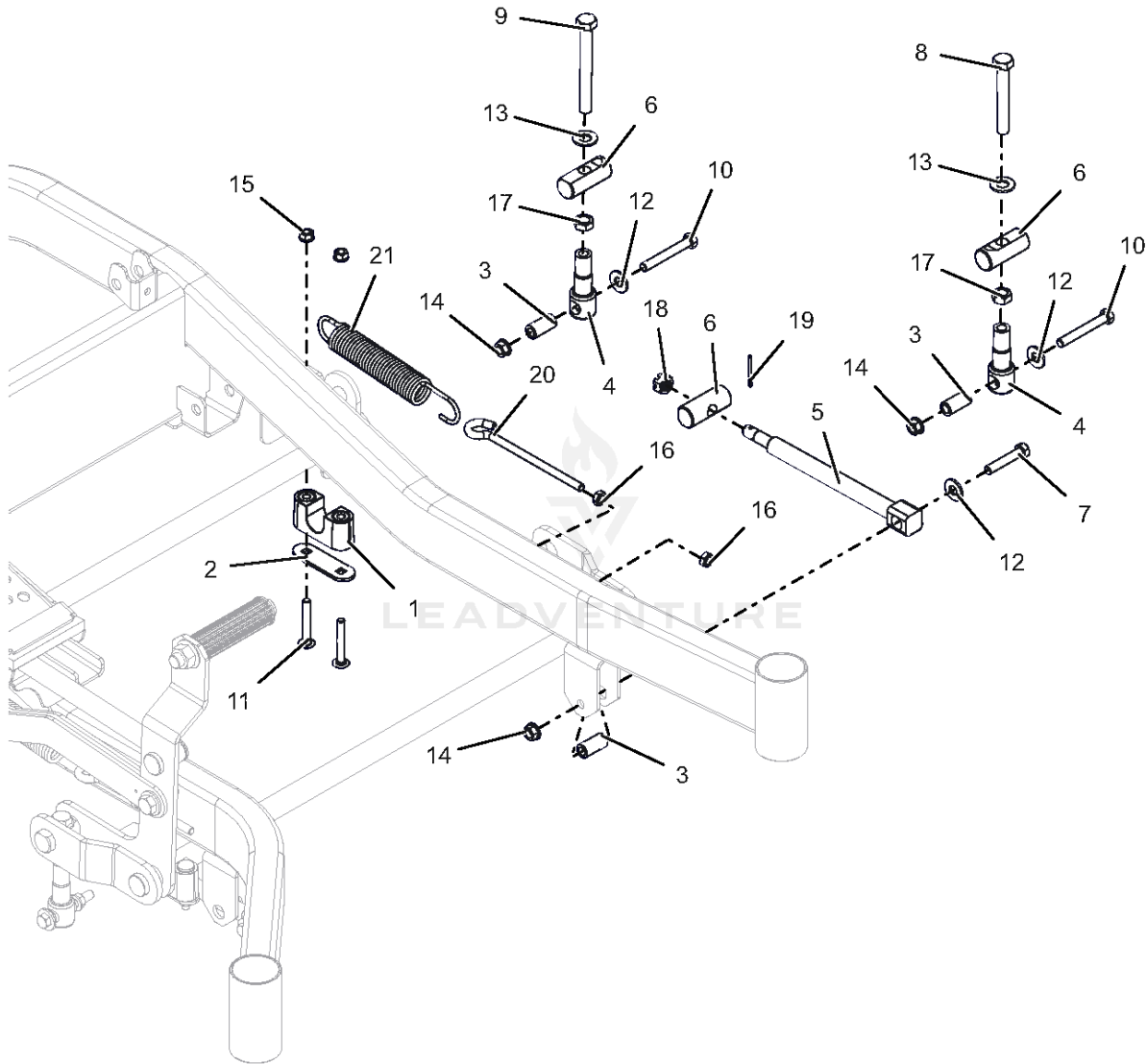

Rendered by LeadVenture, Inc.

AGU991269 Deck Lift - LH

Ref Number	Part Number	Part Description	Context Notes	Quantity
1	AGP07500414	ASM-BUSHING, DECK LIFT		2
2	AGP04766551	PLATE, BEARING SUPPORT		2
3	AGP04895200	SPACER, DECK LEVELING		3
4	AGP05081400	LINK, DECK LIFT FORMED		2
5	AGP05126700	DRAG, LINK-HD		1
6	AGP05149500	PIN, DECK LIFT		3
7	AGP05901718	BLT, HEX .38-16X2.00 G5 ZCC		1
8	AGP05901735	BLT, HEX 0.5-13X3.5F GR5 ZCC		1
9	AGP05901736	BLT, HEX .50-13X4.50F G8 ZCC		1
10	AGP05901813	BLT, HEX .38-16X2.75 G8 ZCC		2
11	AGP06200311	BLT, RHSSN.31-18X2.25 G5 ZCC		4
12	AGP06401008	WSHR, FLT .438X1.00X.083 ZCC		3
13	AGP06401116	WSHR, FLT .557X1.040X.102 ZCC		2
14	AGP06500822	NUT-LK-TOP-FLG .38-16 ZC120		3
15	AGP06500840	NUT, LK-CTR-FLG .31-18 GF ZCC		4
16	AGP06500910	NUT-JAM .375-16 G2 ZCC		2
17	AGP06500911	NUT-JAM .500-13 G2 ZCC		2
18	AGP06505000	NUT-SL .50-13		1
19	AGP06700212	PIN, CTR.12X1.25EXTPRSQCT ZC120		1
20	AGP07001814	BOLT, .38-16 X 5.25-.62 DIA EYE		1
21	AGP08319000	SG-TENS .162X1.25X8.25 WLD 25		1

AGU991269 Deck Lift - RH

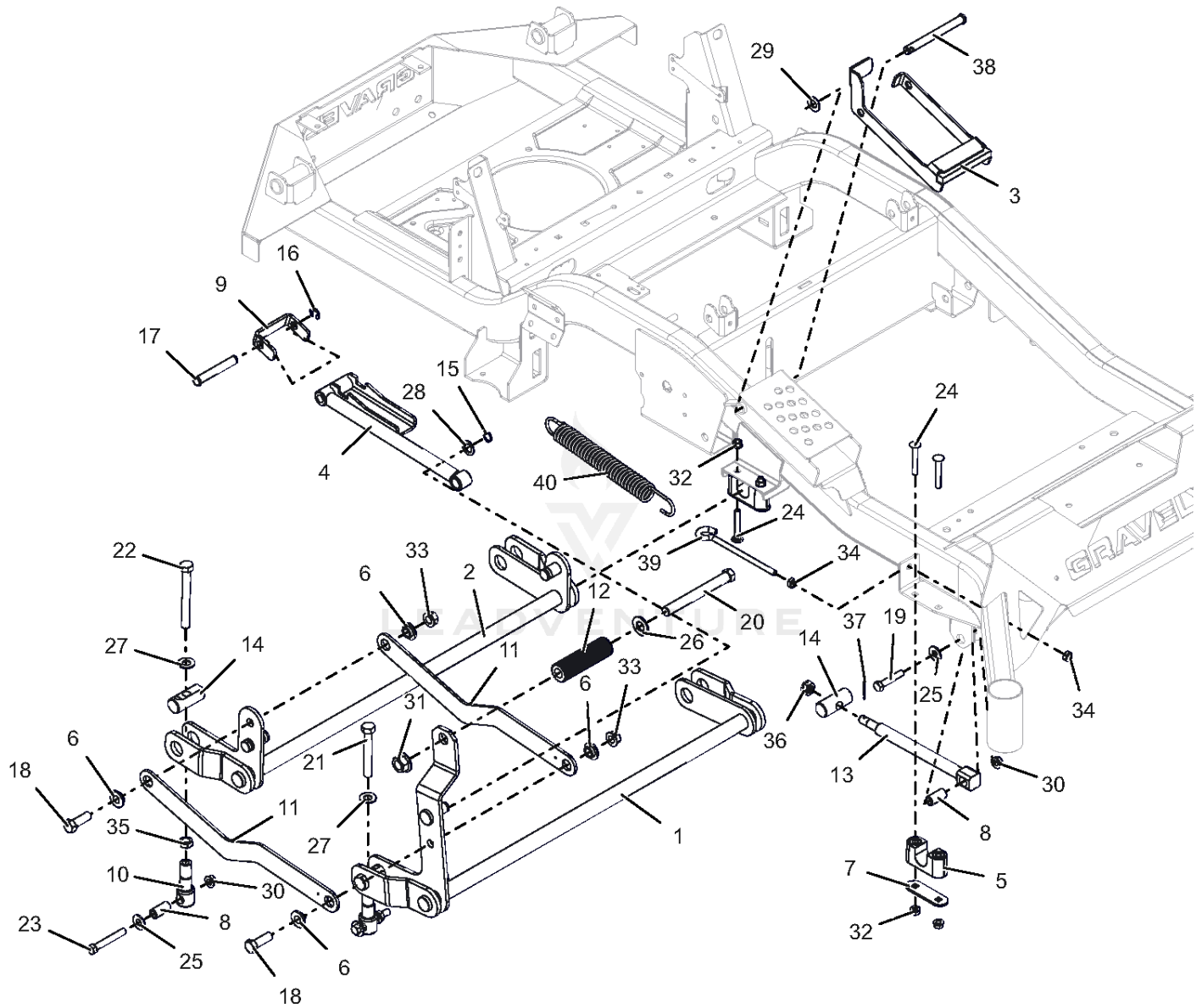

Rendered by LeadVenture, Inc.

AGU991269 Deck Lift - RH

Ref Number	Part Number	Part Description	Context Notes	Quantity
1	AGP05019651	WLDMT, FRONT DECK LIFT PIVOT		1
2	AGP05019751	WLDMT, REAR DECK LIFT PIVOT		1
3	AGP05025251	WLDMT, HOC TRANSFER LOCK (BLACK)		1
4	AGP05186351	WLDMT, HOC LIFT ARM (BLACK)		1
5	AGP07500414	ASM-BUSHING, DECK LIFT		2
6	AGP03989100	BSHG-FLG .515X.750X.310X1.120		4
7	AGP04766551	PLATE, BEARING SUPPORT		2
8	AGP04895200	SPACER, DECK LEVELING		3
9	AGP05077551	BRKT, HOC LINE		1
10	AGP05081400	LINK, DECK LIFT FORMED		2
11	AGP05083951	LINK, DECK		2
12	AGP05120951	ROD, FOOT PEDAL (BLACK)		1
13	AGP05126700	DRAG, LINK-HD		1
14	AGP05149500	PIN, DECK LIFT		3
15	AGP05709200	RG-RTNG-EXT .625X.050		1
16	AGP05710200	RG-RTNG-EXT .500X.042 (E)		1
17	AGP05800210	PIN, .499/.494 x 3.385 CLEVIS		1
18	AGP05901631	BLT, HEX .50-13X1.50 G5 ZCC		2
19	AGP05901718	BLT, HEX .38-16X2.00 G5 ZCC		1
20	AGP05901730	BLT, HEX .62-11X5.50 G5 FBP		1
21	AGP05901735	BLT, HEX 0.5-13X3.5F GR5 ZCC		1
22	AGP05901736	BLT, HEX .50-13X4.50F G8 ZCC		1
23	AGP05901813	BLT, HEX .38-16X2.75 G8 ZCC		2

Ref Number	Part Number	Part Description	Context Notes	Quantity
24	AGP06200311	BLT, RHSSN.31-18X2.25 G5 ZCC		4
25	AGP06401008	WSHR,FLT .438X1.00X.083 ZCC		3
26	AGP06401039	WSHRFLT 5/8SAE CARBHARD FBP		1
27	AGP06401116	WSHR, FLT .557X1.040X.102 ZCC		2
28	AGP06401117	WSHR, FLT .630X1.005X.062 ZCC		1
29	AGP06443300	WSHR-FL-NYL .518X1.000X.080		1
30	AGP06500822	NUT-LK-TOP-FLG .38-16 ZC120		3
31	AGP06500835	NUT,FLG-TOP LK .625-11 FBP		1
32	AGP06500840	NUT,LK-CTR-FLG .31-18 GF ZCC		4
33	AGP06500907	NUT-LK-TOP-FLG .500-13 GF ZCC		2
34	AGP06500910	NUT-JAM .375-16 G2 ZCC		2
35	AGP06500911	NUT-JAM .500-13 G2 ZCC		2
36	AGP06505000	NUT-SL .50-13		1
37	AGP06700212	PIN,CTR.12X1.25EXTPRSQCT ZC120		1
38	AGP06800201	PIN, SLIC-.500X4.97X4.55 -ZC		1
39	AGP07001814	BOLT,.38-16 X 5.25-.62 DIA EYE		1
40	AGP08319000	SG-TENS .162X1.25X8.25 WLD 25		1

AGU991269 Deck, Belts, Blades & Spindles - 48"

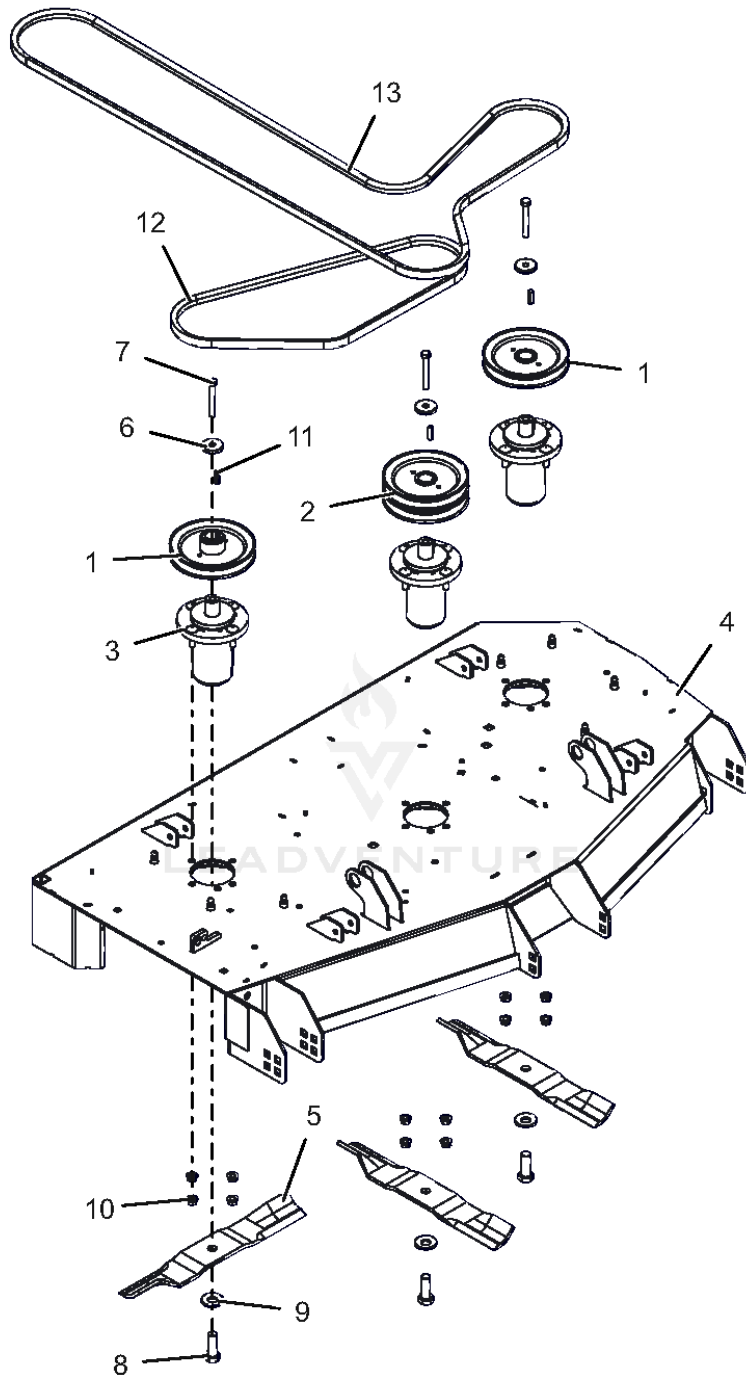

Rendered by LeadVenture, Inc.

AGU991269 Deck, Belts, Blades & Spindles - 48"

Ref Number	Part Number	Part Description	Context Notes	Quantity
1	AGP07332167	PULLEY, SINGLE-1"ID X 6" OD		2
2	AGP07332300	PULLEY, DOUBLE 1.000 ID X 6.000 OD		1
3	AGP58810800	ASM, MAINT FREE ALUM SPINDLE		3
4	AGP59121500	KIT, DECK-48 W/DECALS 7GA XF3 RED		1
5	AGP00450200	BLADE, 16.19" MOWER (HI-LIFT)		3
6	AGP04530500	RETAINER, SHEAVE		3
7	AGP05901813	BLT, HEX .38-16X2.75 G8 ZCC		3
8	AGP05901822	BLT, HEX .62-18X1.75 G8 ZCC		3
9	AGP06445700	WSHR-BLVL .669X1.535X.138		3
10	AGP06500901	NUT-LK-CTR-FLG .375-16 GF ZCC		1
11	AGP06611200	KEY, SQ .25X.25X1.00 RC 40-50		3
12	AGP07200805	V-BELT, B-COGGED		1
13	AGP07200815	V-BELT, HB SECTION		1

AGU991269 Discharge Chute - 44" & 48"

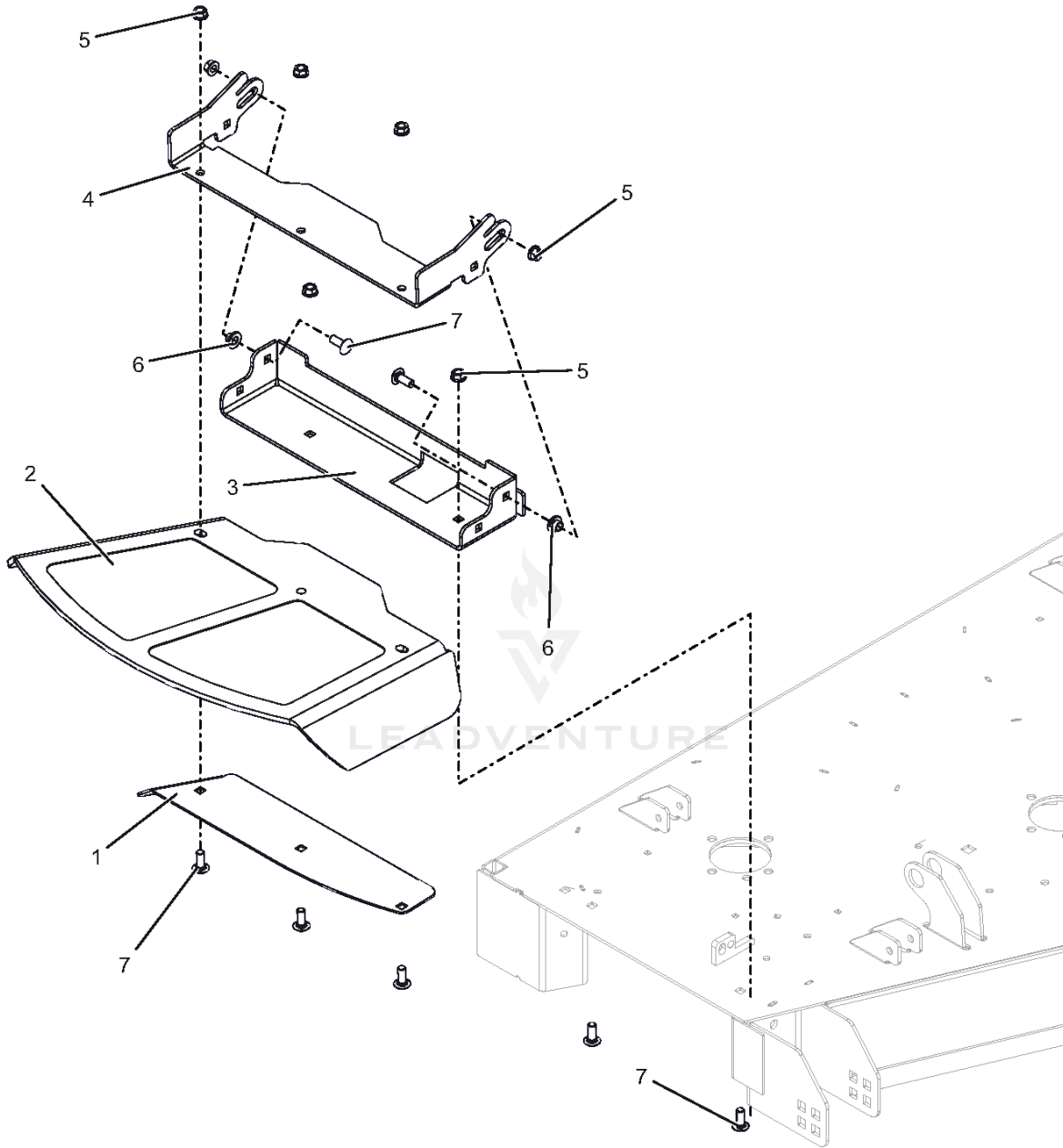

Rendered by LeadVenture, Inc.

AGU991269 Discharge Chute - 44" & 48"

Ref Number	Part Number	Part Description	Context Notes	Quantity
1	AGP04873753	48-60 DISCH CHUTE CLMP PLT-RED		1
2	AGP05269900	CHUTE, FORMED RUBBER DISCHARGE		1
3	AGP59230600	BASE, DISCH CHUTE MTG W/SAFETY		1
4	AGP09458553	BRKT- CHUTE MTG		1
5	AGP06500901	NUT-LK-CTR-FLG .375-16 GF ZCC		7
6	AGP05500435	BSHG-FLG .385X.500X.875X.406		2
7	AGP06200235	BLT,RHSSN .38-16X1.00 G5 ZCC		7

AGU991269 Electrical

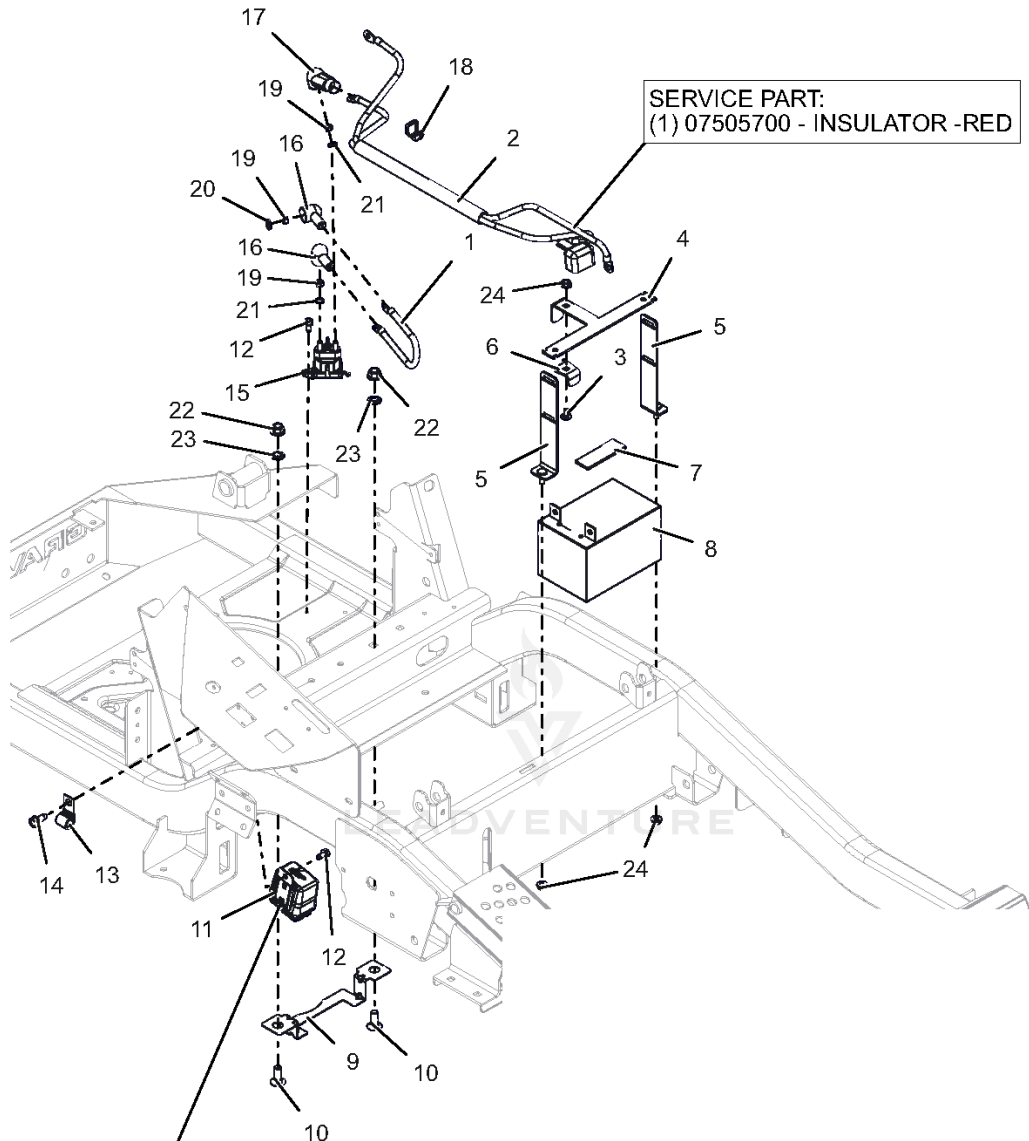

SERVICE PART:
(1) 07505700 - INSULATOR -RED

SERVICE PARTS:
(2) 09293501 DIODE
(2) 05076400 - FUSE - 5A MINI
(1) 04438100 - FUSE - 10A MINI
(1) 04438200 - FUSE - 15A MINI
(1) 04438300 - FUSE - 20A MINI
(1) 04438400 - RELAY
(1) 00191262 - FUSE - 20A ATC

Rendered by LeadVenture, Inc.

AGU991269 Electrical

Ref Number	Part Number	Part Description	Context Notes	Quantity
1	AGP04783300	CABLE, POS W/(2)1/4 RING 9.0LG		1
2	AGP05074100	HARNESS, BATTERY HD		1
3	AGP06200306	BLT, RHSN .25-20X.500 G5 ZCC		1
4	AGP05031551	BRKT, BATTERY TIE DOWN		1
5	AGP05107451	WMT,BATTERY MOUNT HOLD DOWN		2
6	AGP09425700	BRKT, BATTERY HOLD		1
7	AGP04850000	PAD,RBR 1.0"X3.0" W/ADHESIVE		1
8	AGP09425500	BATTERY, 12V 12A -190CCA		1
9	AGP05111451	GUARD, ELECTRICAL HARNESS		1
10	AGP06200313	BLT, RHSN .38-16X1.00 G5 ZCC		2
11	AGP05155300	HARNESS, WIRE		1
12	AGP07400122	SCR-TAP .25-20X.50 HWH ZCC		2
13	AGP06916000	J-CLAMP		1
14	AGP07400127	SCR,TAP .312-18X.75 HWH TR ZCC		1
15	AGP05167200	SOLENOID, STARTER (SEALED)		1
16	AGP07533200	BOOT, EYELET TERMINAL		2
17	AGP07500401	BOOT, .65ID POS		1
18	AGP07500040	CABLE TIE W/ TREE (.25 HOLE)		1
19	AGP06500925	NUT-STD M6-1.0 ZCC		3
20	AGP06300119	WSHR,LK-REG .312X.078 ZCC		1
21	AGP06300118	WSHR,LK- EXT.262X.502X.026 ZCC		2

Ref Number	Part Number	Part Description	Context Notes	Quantity
22	AGP06500726	NUT,NYL-FLG .38-16 GF ZCC		2
23	AGP07009900	NUT-PUSH .38 DIA. PAL ZINC		2
24	AGP06500903	NUT-LK-TOP-FLG .250-20 GF ZCC		3
25	AGP07505700	INSULATOR	SERVICE PART	1
26	AGP09293501	DIODE, CONNECTOR SHELL	SERVICE PART	2
27	AGP05076400	FUSE, 5 AMP MINI-ATC	SERVICE PART	2
28	AGP04438100	FUSE,10 AMP MINI-ATC	SERVICE PART	1
29	AGP04438200	FUSE,15 AMP MINI-ATC	SERVICE PART	1
30	AGP04438300	FUSE,20 AMP MINI ATC	SERVICE PART	1
31	AGP04438400	RELAY,MICRO5 TERML W/RESISTOR	SERVICE PART	1
32	AGP00191262	FUSE, 20 AMP BLADE S/O	SERVICE PART	1

AGU991269 Engine - Kawasaki FR691V

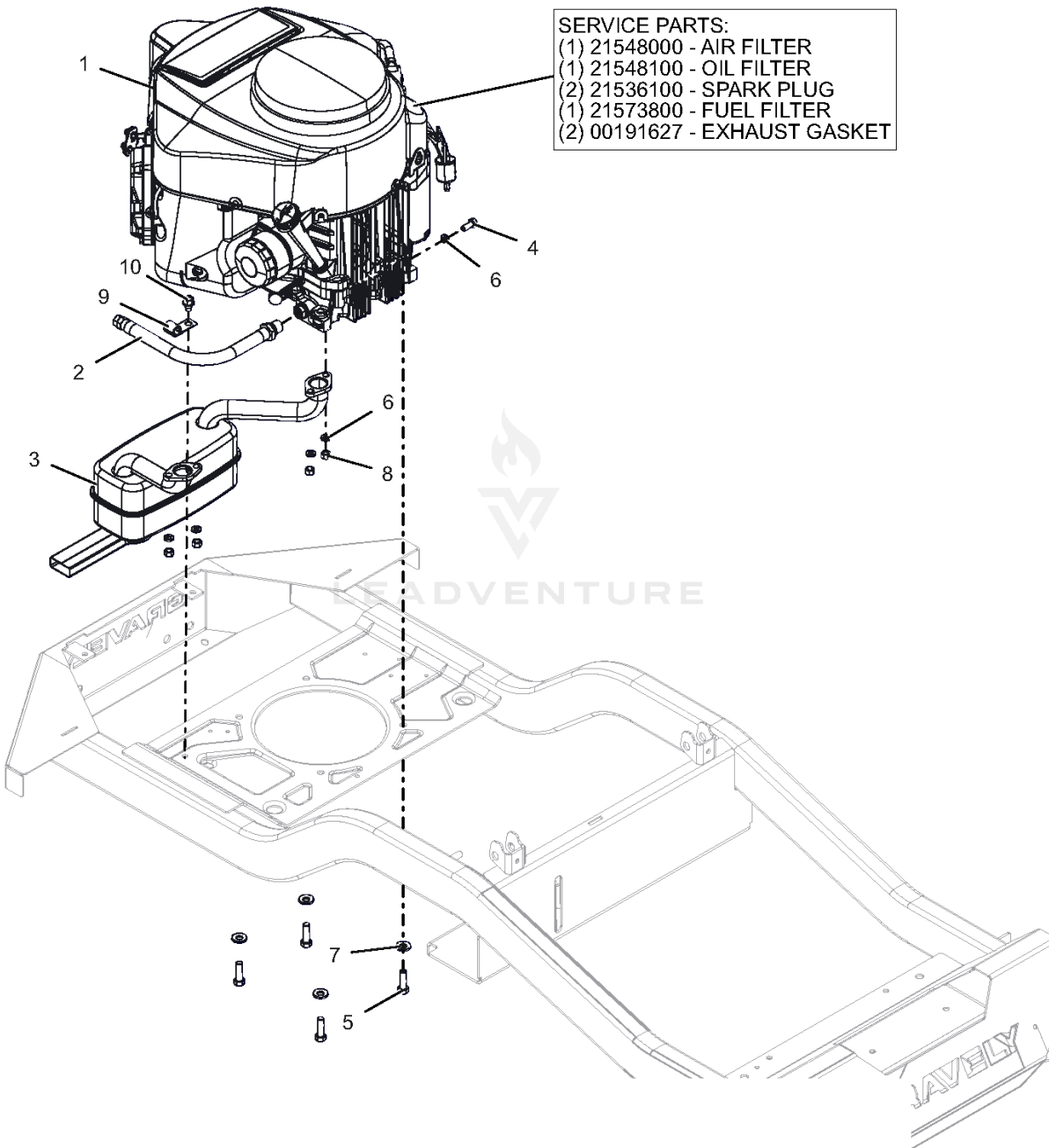

Rendered by LeadVenture, Inc.

AGU991269 Engine - Kawasaki FR691V

Ref Number	Part Number	Part Description	Context Notes	Quantity
1	AGP08200717	ENGINE, KAWASAKI FR691 23HP		1
2	AGP07001730	HOSE, OIL DRAIN		1
3	AGP04754300	MUFFLER, KAWASAKI		1
4	AGP05901628	BLT, HEX M8-1.25X20 G8.8 ZCC		1
5	AGP05901808	BLT, HEX .38-16X1.25 G5 ZCC NT		4
6	AGP06300119	WSHR,LK-REG .312X.078 ZCC		5
7	AGP06400927	WASHER, 3/8" SPRING DISC		4
8	AGP06500919	NUT-LK-TOP-FLG M8 ZCC		4
9	AGP06916000	J-CLAMP		1
10	AGP07400126	SCR,TAP .375-16X.50 HWH TR ZCC		1
11	AGP21548000	AIR FILTER, KAWASAKI FR	SERVICE PART	1
12	AGP21548100	OIL FILTER, KAWASAKI FR	SERVICE PART	1
13	AGP21536100	PLUG, SPARK	SERVICE PART	2
14	AGP21573800	FUEL FILTER	SERVICE PART	1
15	AGP00191627	GASKET, MUFFLER S/O	SERVICE PART	2

AGU991269 Engine Guard & Fenders

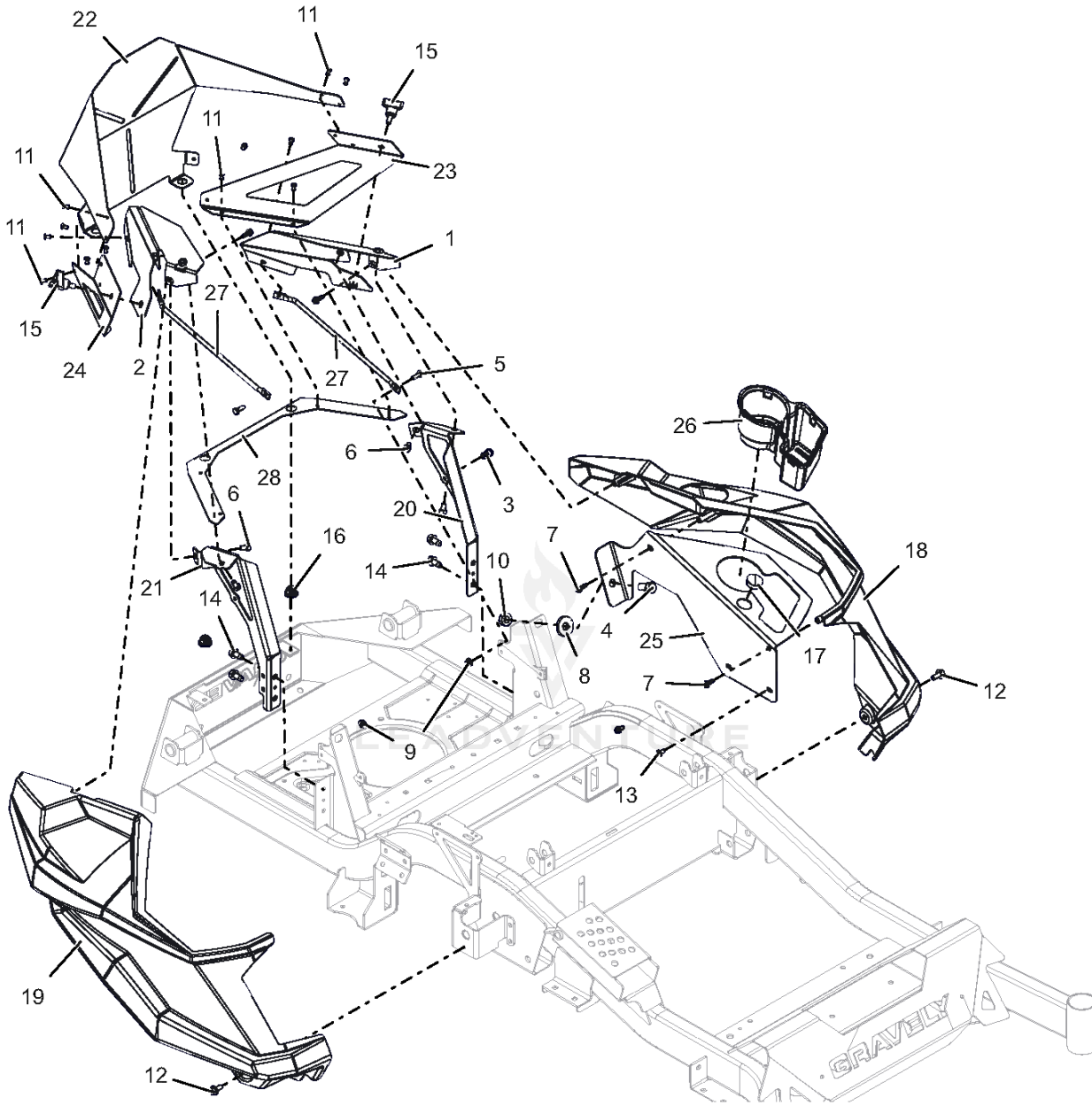

Rendered by LeadVenture, Inc.

AGU991269 Engine Guard & Fenders

Ref Number	Part Number	Part Description	Context Notes	Quantity
1	AGP09188853	PANEL, LH (RED)		1
2	AGP09188953	PANEL, RH (RED)		1
3	AGP04451600	CLIP, CABLE GUIDE		1
4	AGP05901715	BLT, HEX .50-13X1.00 G5 ZCC		1
5	AGP05901716	BLT, HEX .25-20X.75 G5 ZCC		2
6	AGP05901904	BLT, HEX .31-18X.50 GR5 ZCC		4
7	AGP06100231	SCR, PLASTITE-HWH 0.25 X 0.75 ZC120		4
8	AGP06401225	WASHER- FLT .562X1.50X.187 ZCC		1
9	AGP06500821	NUT-LK-CTR-FLG .25-20 ZC120		2
10	AGP06500907	NUT-LK-TOP-FLG .500-13 GF ZCC		1
11	AGP06800107	RIVET, #66 STEEL POP PD BLACK		12
12	AGP07001820	BLT, SERHFWH 0.312-18X0.75 GR5 ZCC		2
13	AGP07400122	SCR-TAP .25-20X.50 HWH ZCC		2
14	AGP07400129	SCR,TAP .375-16X.75 HWH TR ZCC		4
15	AGP07500008	KNOB,WING STUD 5/16-18 X .75		2
16	AGP07500407	GROMMET, 10MM BOLLHOFF		2
17	AGP07500602	PLUG, HOLE 1.125 DOMED		1
18	AGP09188100	FENDER, LH		1
19	AGP09188200	FENDER, RH		1
20	AGP09188353	BRKT, LH FENDER MTG (RED)		1
21	AGP09188453	BRKT, RH FENDER MTG (RED)		1
22	AGP09188551	WRAP, REAR (BLACK)		1

Ref Number	Part Number	Part Description	Context Notes	Quantity
23	AGP09188653	WRAP, REAR - LH (RED)		1
24	AGP09188753	WRAP, REAR - RH (RED)		1
25	AGP09189153	PANEL, HD CUPHOLDER (RED)		1
26	AGP09190800	HOLDER, CUP		1
27	AGP09362700	ROD, STIFFENER		2
28	AGP09363253	STIFFENER, BACK WRAP (RED)		1

AGU991269 Frame - 44", 48" & 52"

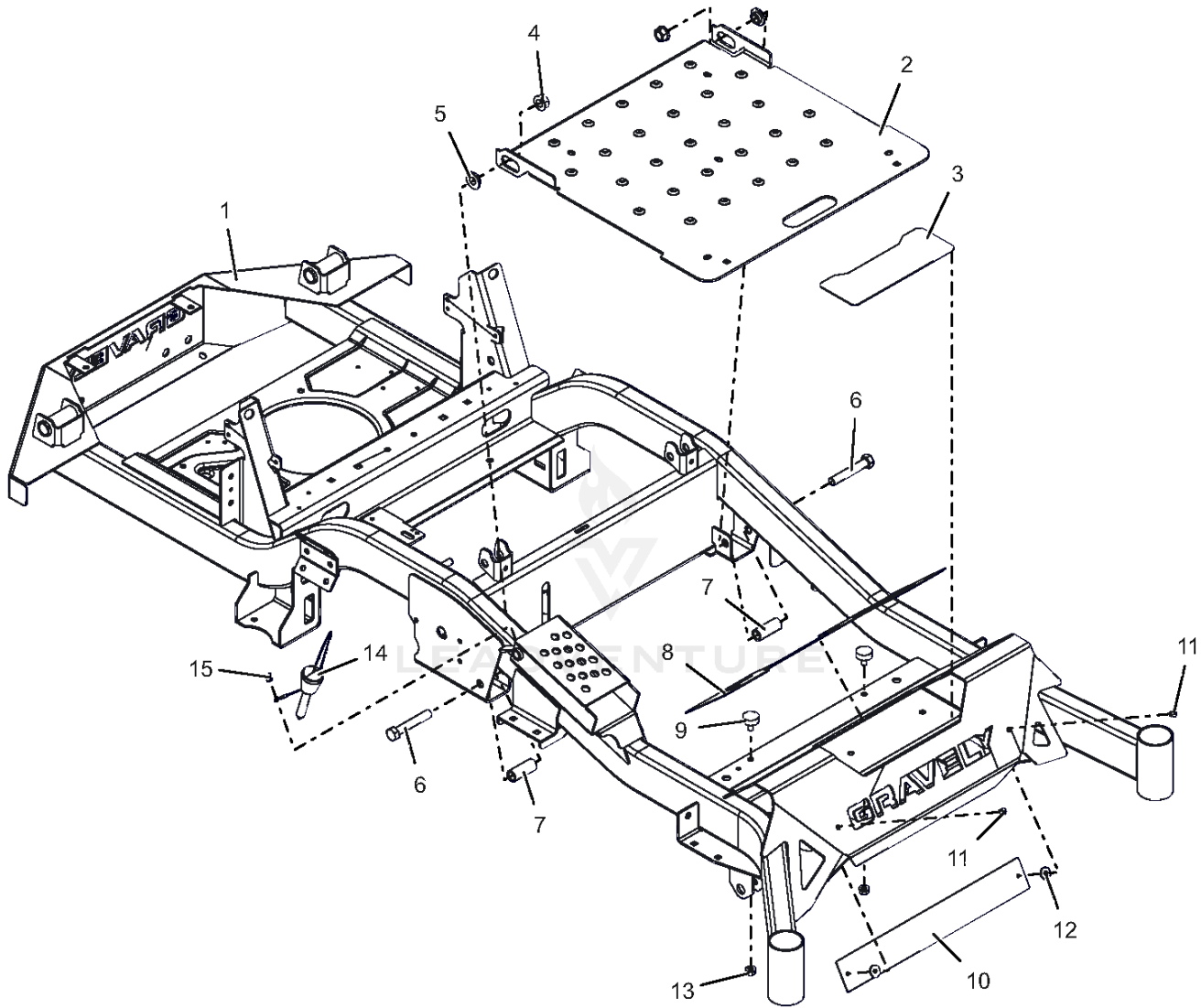

Rendered by LeadVenture, Inc.

AGU991269 Frame - 44", 48" & 52"

Ref Number	Part Number	Part Description	Context Notes	Quantity
1	AGP59117500	WLDMT, MAIN FRAME - APEX 60		1
2	AGP59113500	KIT,ACCESS PANEL W/DECALS-RED		1
3	AGP05109100	GRIP, STEP		1
4	AGP06500907	NUT-LK-TOP-FLG .500-13 GF ZCC		2
5	AGP03989100	BSHG-FLG .515X.750X.310X1.120		2
6	AGP05901737	BLT, HEX .50-13X3.00 G5 ZCC		2
7	AGP05501319	SPACER, .515X.75X1.83		2
8	AGP05104800	GRIP, FRONT		1
9	AGP07533600	BUMPER, RUBBER		2
10	AGP04718451	PLATE, BACK FOOT-REST XL		1
11	AGP06800120	RIVET, .1875 AL/AL .126-.250		2
12	AGP06401214	WSHR, RBR W/ADHESIVE .25X.75X.06		2
13	AGP06500815	NUT,SPNLK-FLG .31-18 G5 ZCC		2
14	AGP06800218	PIN, MAGNETIC .50X2.70		1
15	AGP07001918	POST, & SCREW, PUSH LOCK .25 X .25		1

AGU991269 Front Caster Wheels

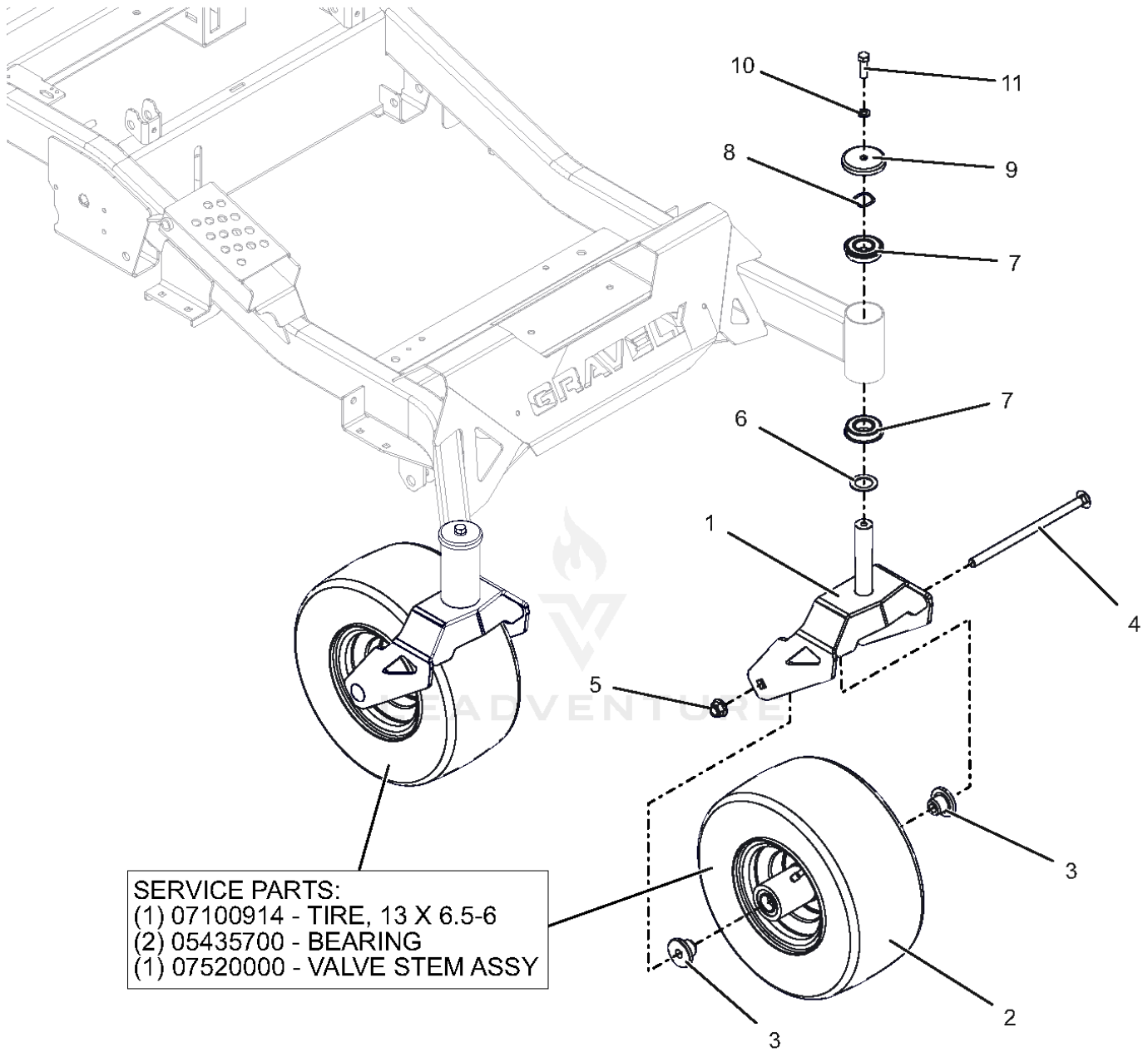

Rendered by LeadVenture, Inc.

AGU991269 Front Caster Wheels

Ref Number	Part Number	Part Description	Context Notes	Quantity
1	AGP09187053	WLDMT, CASTER FORK-HD (RED)		1
2	AGP07101515	ASM,WHL/TIRE 13X6.50-6 LG BLK		2
3	AGP00675300	SPACER, FRONT WHEEL		2
4	AGP06200510	BOLT, RHNS .50-13X9.00 G5 ZCC NS		1
5	AGP06500810	NUT,NYL-FLG .50-13 GF ZCC		1
6	AGP06416600	WSHR-HRD-THRS 1.007X1.542X.062		1
7	AGP05400728	BEARING, BALL -2.000 OD X 1.000 ID X .5625 W/RING		2
8	AGP06401030	WSHR-WAVE 1.0X1.25X.028 .145FH		1
9	AGP09692800	SHIELD, AXLE BEARING		1
10	AGP06300130	WSHR, LK-REG 0.377 X 0.094 ZB500		1
11	AGP05902203	BLT, HEX 0.375-16X1.25 GR5 ZB500		1
12	AGP07100914	TYRE, 13X6.50-6 SMOOTH	SERVICE PART	1
13	AGP05435700	BRG, 25MM ID X 52MM OD X 15MM	SERVICE PART	2
14	AGP07520000	VALVE STEM ASS'Y	SERVICE PART	1

AGU991269 Fuel System

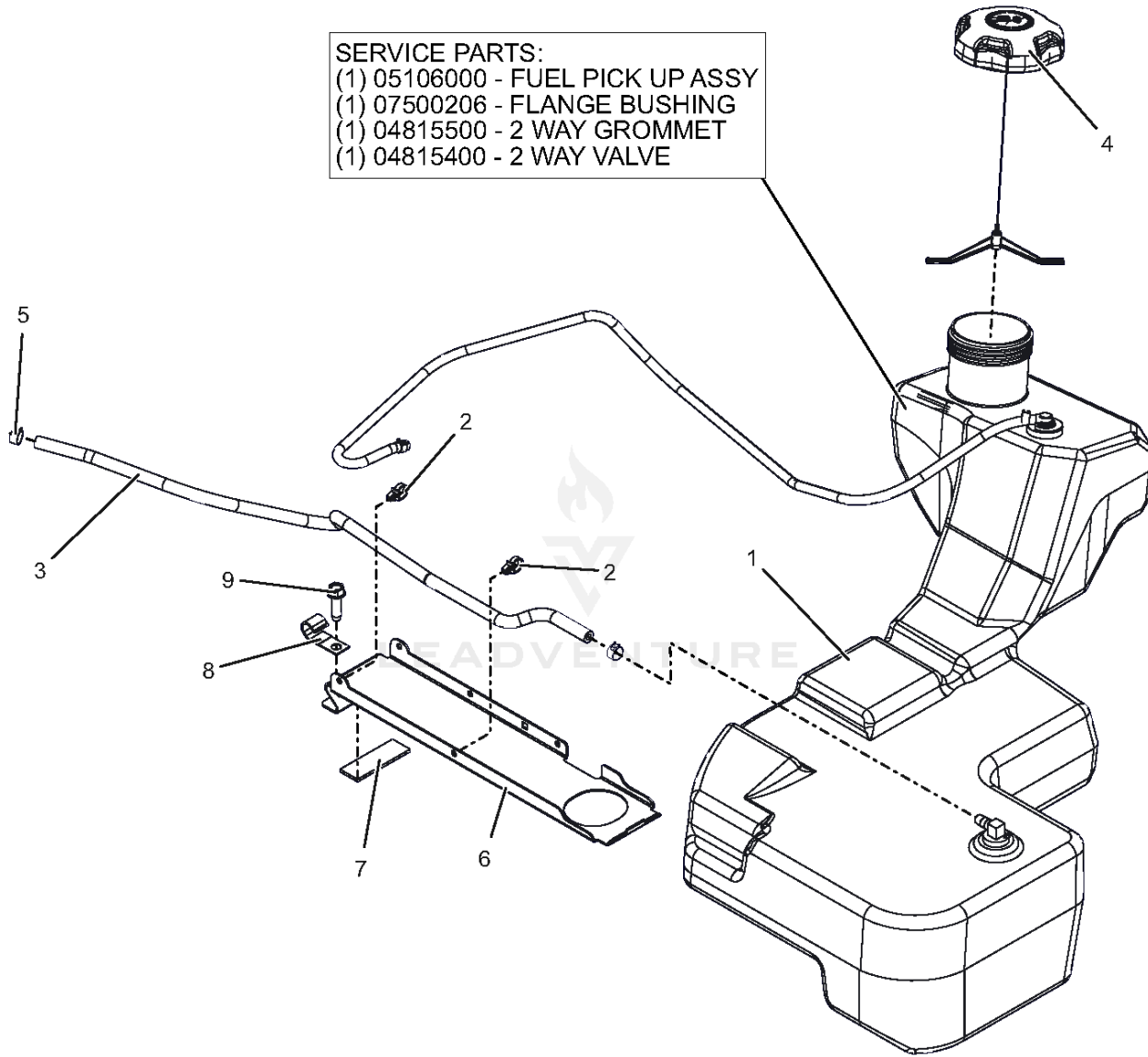

Rendered by LeadVenture, Inc.

AGU991269 Fuel System

Ref Number	Part Number	Part Description	Context Notes	Quantity
1	AGP09167300	ASM, FUEL TANK-HD		1
2	AGP00367900	ROUTING CLIP (1/2" ID)		2
3	AGP03278100	1 INCH OF HOSE, .25 LOW-PERM BULK GAS		1
4	AGP09190300	CAP, FUEL - 3.50 RATCHET INLET VENT		1
5	AGP03278800	CLAMP, FUEL LINE		1
6	AGP05024151	BRKT, FUEL TANK HOLD DOWN		1
7	AGP04850000	PAD,RBR 1.0"X3.0" W/ADHESIVE		1
8	AGP06916000	J-CLAMP		1
9	AGP07400128	SCR,TAP .375-16X1.25HWH TR ZCC		1
10	AGP05106000	ASM, HD FUEL PICK-UP	SERVICE PART	1
11	AGP07500206	BSHG-FLG .375X1.062X.625 NITR	SERVICE PART	1
12	AGP04815500	GROMMET, 2-WAY	SERVICE PART	1
13	AGP04815400	VALVE, 2-WAY	SERVICE PART	1

AGU991269 Heat Shield

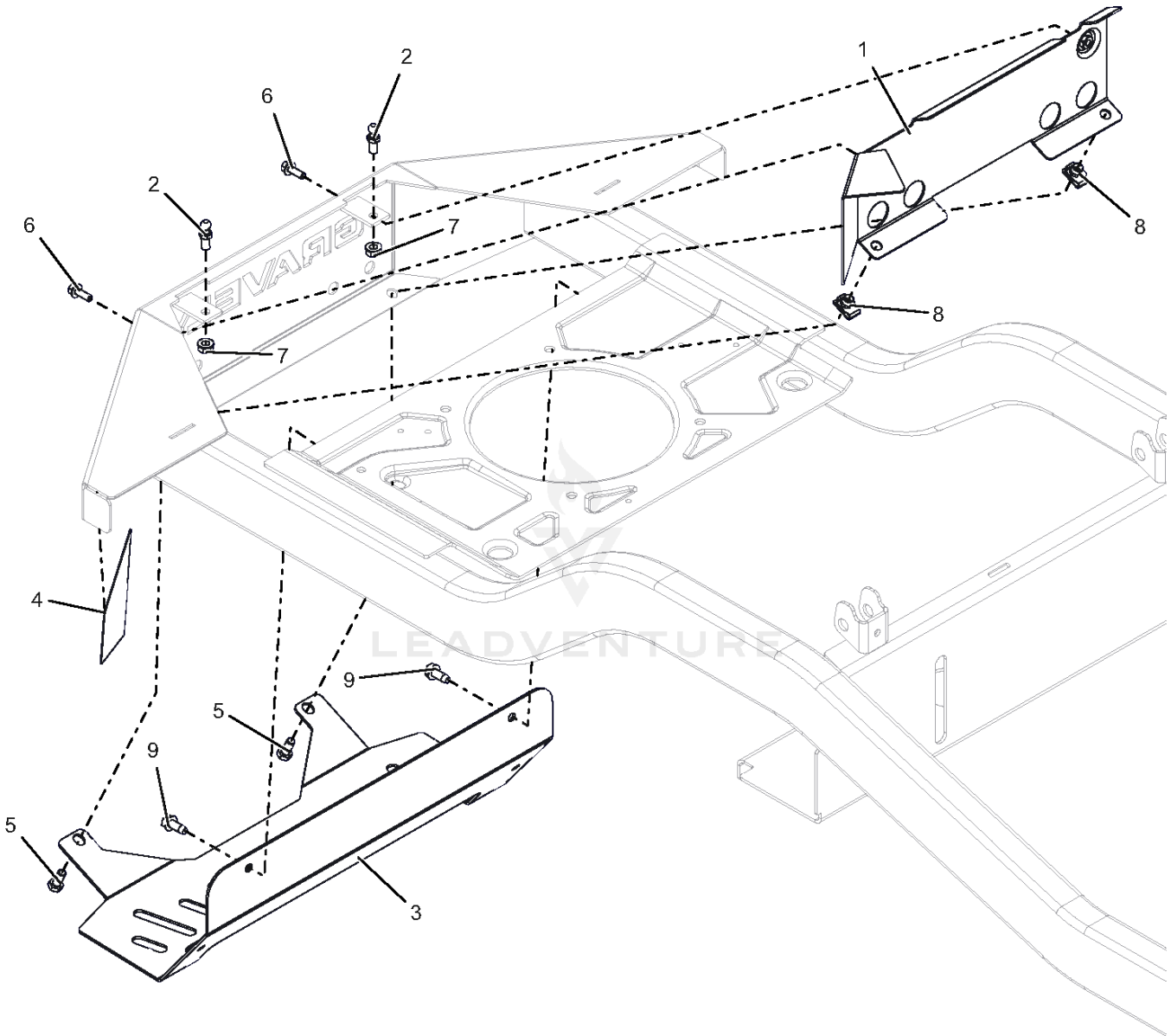

Rendered by LeadVenture, Inc.

AGU991269 Heat Shield

Ref Number	Part Number	Part Description	Context Notes	Quantity
1	AGP05116751	WMT, HEAT BAFFLE		1
2	AGP03652200	STUD- BALL		2
3	AGP05082851	SHIELD, HEAT (HD)		1
4	AGP05116800	TAPE, HEAT DEFLECTOR		1
5	AGP05901704	BLT,HEX .31-18X.75 G5 ZCC		2
6	AGP05901731	BLT,HEX-FLG .25-20X.75 G5 BFP		2
7	AGP06500840	NUT,LK-CTR-FLG .31-18 GF ZCC		2
8	AGP07000829	NUT-CLIP RETAINER 5/16-18X.56		2
9	AGP07400127	SCR,TAP .312-18X.75 HWH TR ZCC		2

AGU991269 Idlers & Sheaves - 44" & 48"

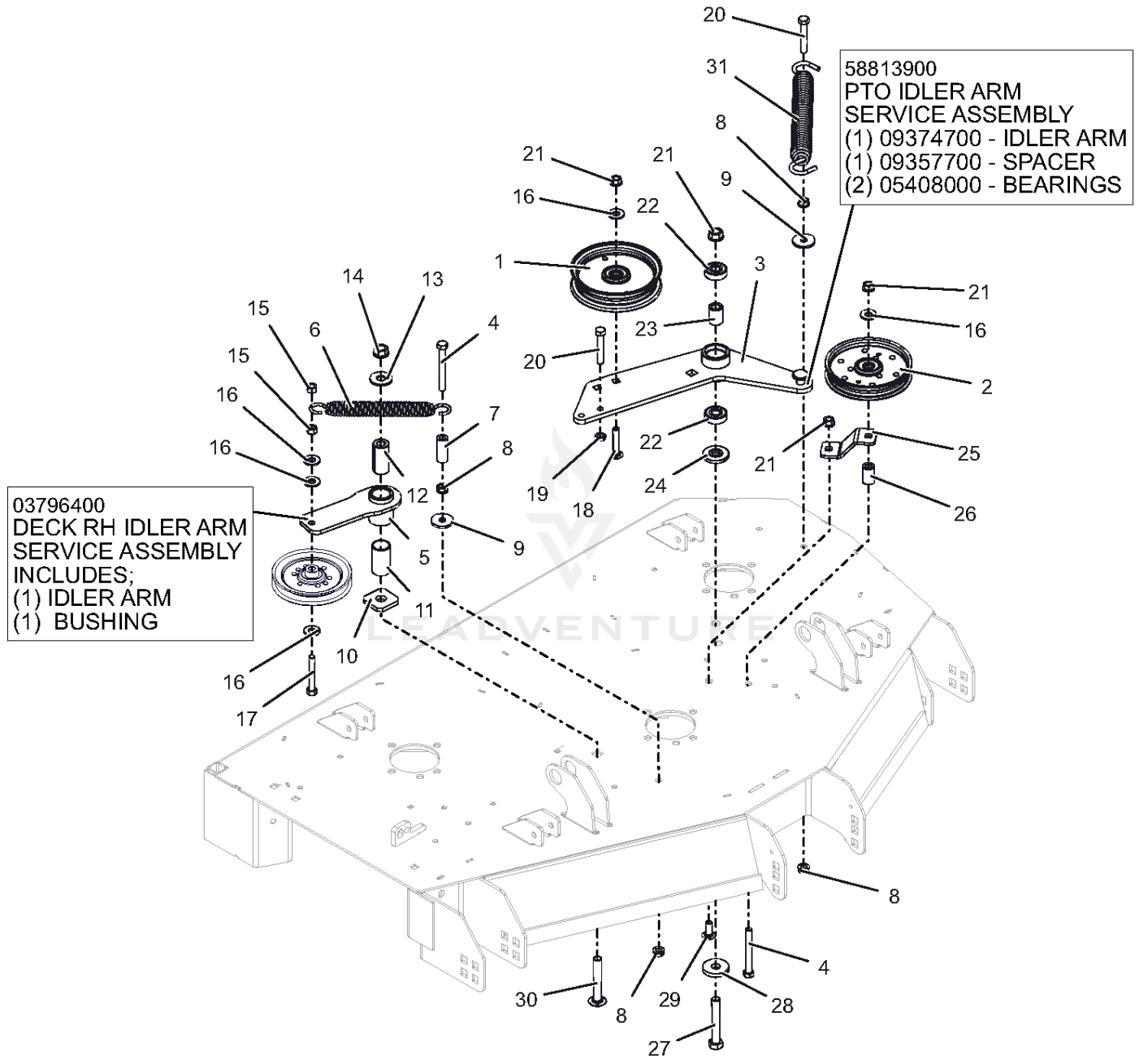

Rendered by LeadVenture, Inc.

AGU991269 Idlers & Sheaves - 44" & 48"

Ref Number	Part Number	Part Description	Context Notes	Quantity
1	AGP07351200	IDLER- FLAT - 5.00" X .75"		1
2	AGP07352400	IDLER- 5" FLANGED		1
3	AGP09374700	WLDMT, IDLER ARM PT660		1
4	AGP05901817	BLT, HEX .38-16X3.25 G5 ZCC		2
5	AGP03774151	WMT, IDLER ARM - BLACK		1
6	AGP08300728	SPRING- EXTENSION		1
7	AGP05278000	HOSE, .38 X 1.65		1
8	AGP06500735	NUT, SPNLK-FLG .38-16 G5 ZCC		4
9	AGP06401121	WSHR,FLT .406X1.375X.135 ZCC		2
10	AGP06400829	WSHR-FLT .640X1.75X.250		1
11	AGP05501234	BSHG, 1.00X1.125X1.937		1
12	AGP01581700	BSHG, SPCR .502X.997X2.03 PM		1
13	AGP06401012	WSHR,FLT .563X1.375X.109 ZCC		1
14	AGP06500902	NUT-LK-CTR-FLG .500-13 GG ZCC		1
15	AGP06500825	NUT-LK-CTR .38-16 ZC120		2
16	AGP06401008	WSHR,FLT .438X1.00X.083 ZCC		5
17	AGP05901812	BLT, HEX .38-16X2.50 G5 ZCC		1
18	AGP06200323	BLT,RHSSN.375-16X2.00 G5 ZCC		1
19	AGP06500910	NUT-JAM .375-16 G2 ZCC		1
20	AGP05901640	BLT,HEX .38-16X2.25 G5 ZCC		2
21	AGP0650090	NUT, FLG-CTR LK.		4
22	AGP05408000	BRG-BALL .500X1.38X.437		2

Ref Number	Part Number	Part Description	Context Notes	Quantity
23	AGP09357700	SPACER .510 X .75 X 1.1485		1
24	AGP04714600	SPACER, IDLER ARM		1
25	AGP04981853	PTO FIXED IDLER MTG BRKT -RED		1
26	AGP05501308	BUSHING, SLV .380X.750X1.190		1
27	AGP05901634	BLT,HEX .50-13X3.25 G5 ZCC		1
28	AGP06401213	WSHR-FL-STL 0.557X1.625X0.25 ZCC		1
29	AGP06200235	BLT,RHSSN .38-16X1.00 G5 ZCC		1
30	AGP06200339	BTL,RHSSN .500-13 X 3.25 G5 ZCC		1
31	AGP08300708	SPRING, EXTENSION		1
32	AGP58813900	PTO IDLER ARM	SERVICE PART	1
33	AGP09374700	WLDMT, IDLER ARM PT660	SERVICE PART	1
34	AGP09357700	SPACER .510 X .75 X 1.1485	SERVICE PART	1
35	AGP05408000	BRG-BALL .500X1.38X.437	SERVICE PART	2
36	AGP03796400	ASM, IDLER ARM (DECK)	SERVICE PART	1

AGU991269 Parking Brake

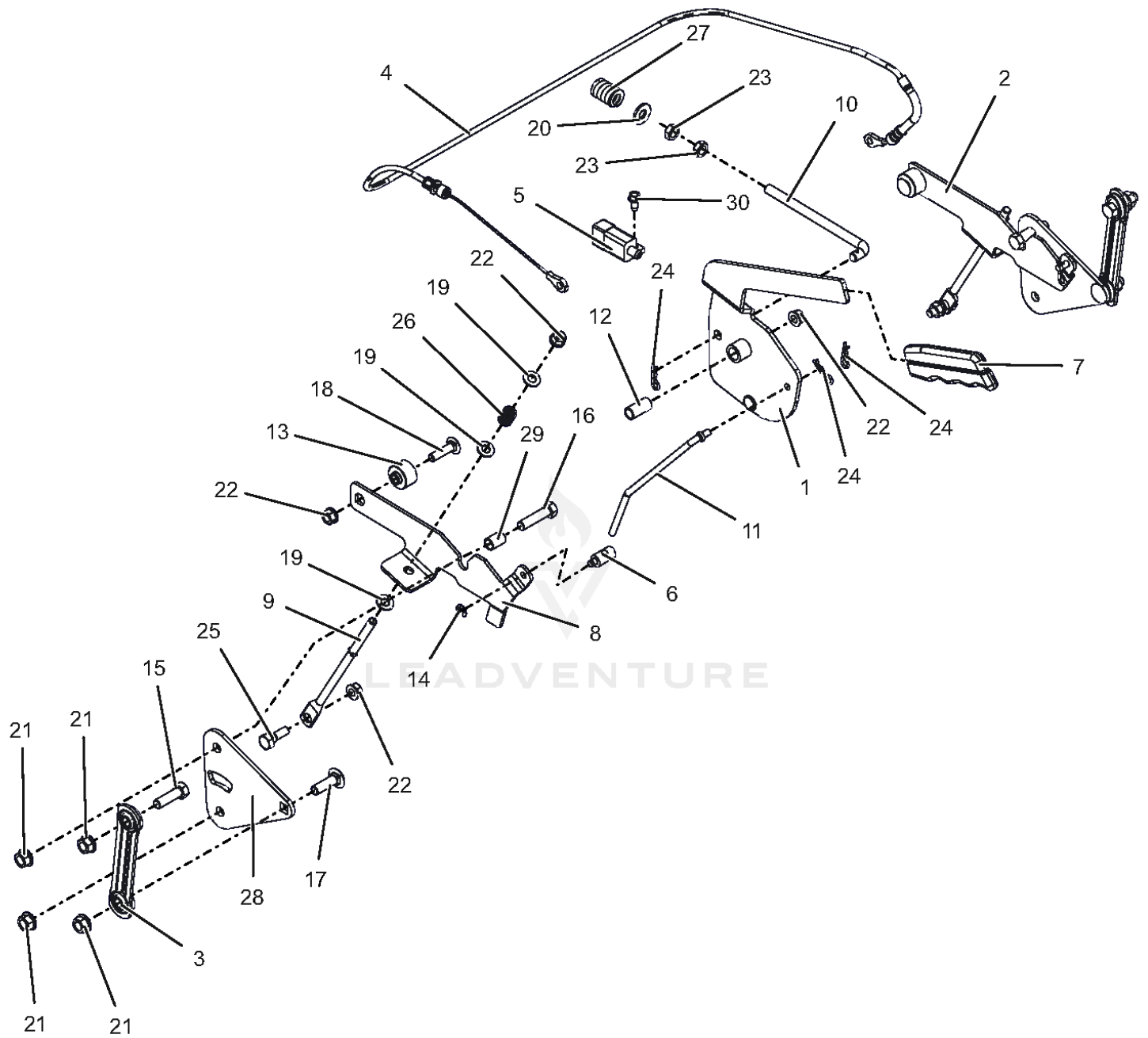

Rendered by LeadVenture, Inc.

AGU991269 Parking Brake

Ref Number	Part Number	Part Description	Context Notes	Quantity
1	AGP04998551	LEVER, PARKING BRAKE		1
2	AGP04998600	ARM, BRAKE - LH (W/PIN)		1
3	AGP05199700	LINK, STAMPED STEERING		2
4	AGP06900706	CABLE, BRAKE - PARKING		1
5	AGP09675800	SWITCH, BRAKE NO-NO-POST & HOLE		1
6	AGP03764800	TRUNION, 1/4-20		1
7	AGP05097200	GRIP, PARKING		1
8	AGP09389500	ARM, BRAKE - RH		1
9	AGP04999000	ROD, LINK - TRANSMISSION BRAKE		2
10	AGP04999100	ROD, OVER CENTER		1
11	AGP05000600	ROD, BRAKE LINK		1
12	AGP05500106	BSHG-SLV .385X.500X1.045		1
13	AGP05501315	SPCR, FLANGE		2
14	AGP05700125	RG-RTNG-EXT .250X.025		1
15	AGP05901724	BLT, HEX .38-16X1.25 G5 ZCC		2
16	AGP05901928	BLT, HEX .38-16X1.50 G5 ZCC		2
17	AGP06200236	BLT,RHSSN .38-16X1.25 G5 ZCC		2
18	AGP06200310	BTL,RHSSN .313-18 X 1.25 G5 ZCC		2
19	AGP06401017	WSHR,FLT .344X.688X.065 ZCC		6
20	AGP06401023	WSHR,FLT .375X.875X.083 ZCC		1
21	AGP06500822	NUT-LK-TOP-FLG .38-16 ZC120		8
22	AGP06500904	NUT-LK-TOP-FLG .312-18 GF ZCC		7

Ref Number	Part Number	Part Description	Context Notes	Quantity
23	AGP06500910	NUT-JAM .375-16 G2 ZCC		2
24	AGP06700222	PIN, HAIR #213 .08X1.19 ZCC		4
25	AGP07001734	BOLT,SHLDR .38X.25 -.31-18X.75		2
26	AGP08300028	SPRING, COMPRESSION		2
27	AGP08320900	SG-COMP .187X.56X1.62		1
28	AGP09191051	PLATE, TRANSAXLE (BLACK)		2
29	AGP09374800	SPCR SLEEVED .385X.500X.718		2
30	AGP07400122	SCR-TAP .25-20X.50 HWH ZCC		1

AGU991269 Rear Tyres & Transaxles - 48"

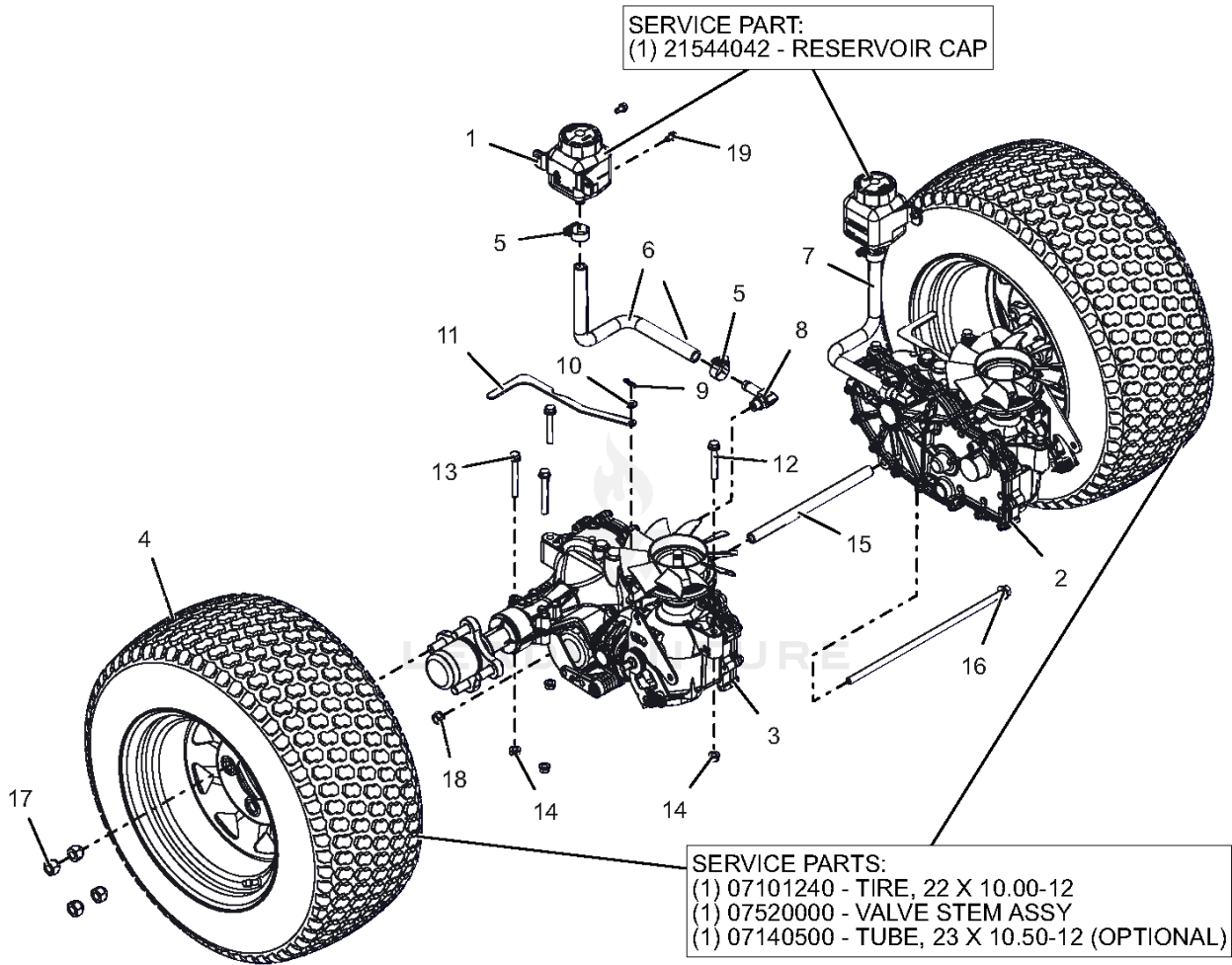

Rendered by LeadVenture, Inc.

AGU991269 Rear Tyres & Transaxles - 48"

Ref Number	Part Number	Part Description	Context Notes	Quantity
1	AGP02970200	TANK, EXPANSION		2
2	AGP09360000	TRANSAXLE, ZT3100 - LH		1
3	AGP09360100	TRANSAXLE, ZT3100 - RH		1
4	AGP07101521	ASM-WHL/TIRE 22X10-12 LG BLK		2
5	AGP06923500	CLAMP,.88 DIA. HOSE		4
6	AGP07001803	HOSE, FORMED EXPANSION -HD RH		1
7	AGP07001804	HOSE, FORMED EXPANSION -HD LH		1
8	AGP07001528	FITTING, HYD (90 DEG)		2
9	AGP06700223	PIN, HAIR #225 .072X1.09		2
10	AGP06401001	WSHR,FLT .281X.625X.065 ZCC		2
11	AGP05076751	BRKT, VALVE DUM		2
12	AGP05901910	BLT,HEX-FLG .31-18X2.25 G5 ZCC		4
13	AGP05901911	BLT,HEX-FLG .31-18X2.75 G5 ZCC		4
14	AGP06500840	NUT,LK-CTR-FLG .31-18 GF ZCC		8
15	AGP05196451	SPCR, TRANSAXLE .406 ID X .630 OD X 9.95LG (BLACK)		1
16	AGP05901903	BLT, HEX-FLG 0.375-16X13 GR5 ZC120		1
17	AGP06500926	NUT, WHEEL .50-20 ZCC		8
18	AGP06500822	NUT-LK-TOP-FLG .38-16 ZC120		1
19	AGP07400122	SCR-TAP .25-20X.50 HWH ZCC		4
20	AGP21544042	CAP, HYDRO RESERVOIR REPLAC.	SERVICE PART	1
21	AGP07101240	TIRE, 22X10.00-12	SERVICE PART	1
22	AGP07520000	VALVE STEM ASS'Y	SERVICE PART	1
23	AGP07140500	TUBE 22,23&24X8.50/9.50/10.00/10.50/12.00-12	SERVICE PART	1

AGU991269 Seat

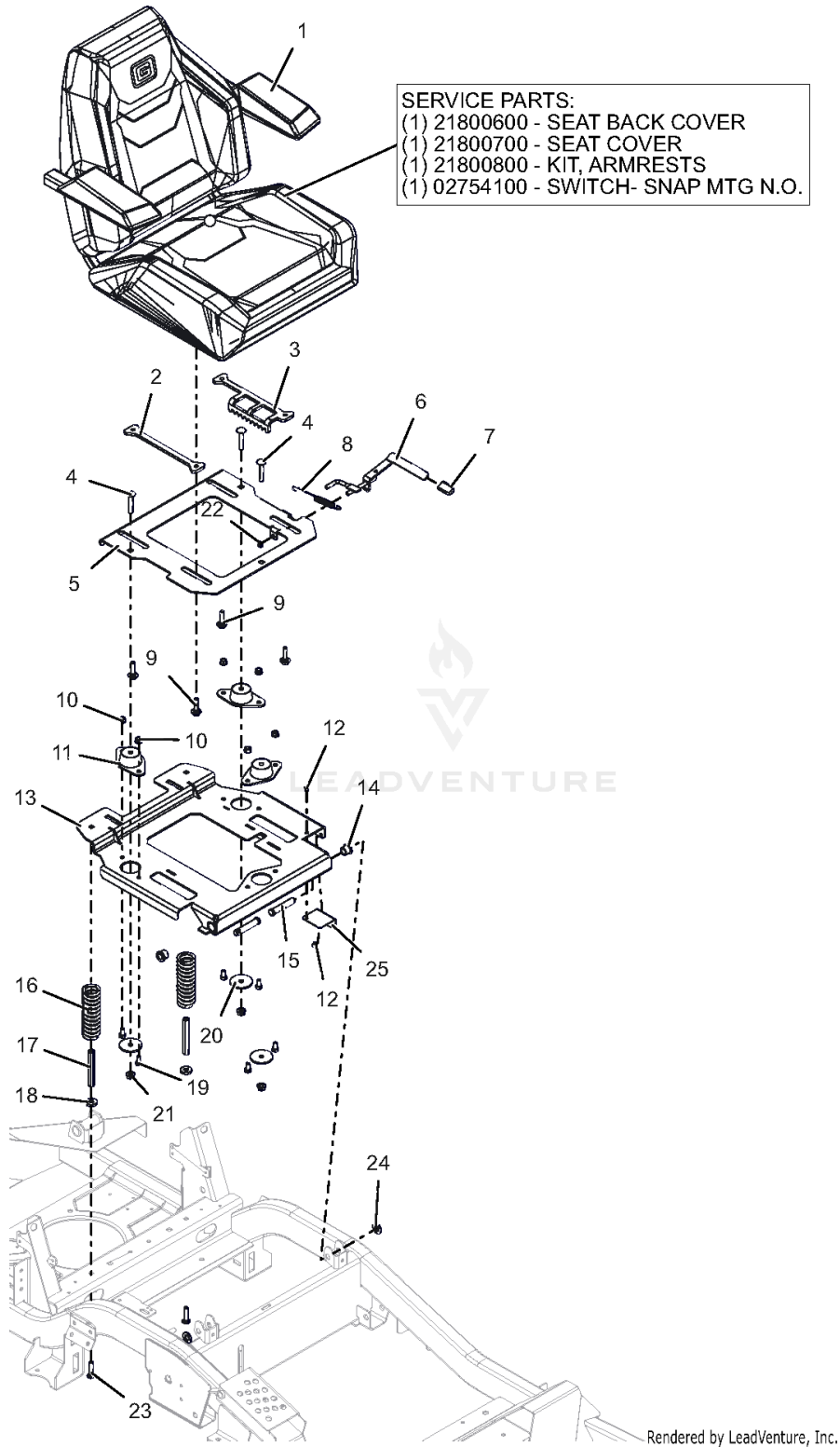

Rendered by LeadVenture, Inc.

AGU991269 Seat

Ref Number	Part Number	Part Description	Context Notes	Quantity
1	AGP30137200	SEAT- ZTXL MY23 (WOOD)		1
2	AGP09363451	PLATE, ADJ SEAT SLIDE (BLACK)		1
3	AGP09363551	PLATE, SEAT ADJ (BLACK)		1
4	AGP06200323	BLT,RHSSN.375-16X2.00 G5 ZCC		3
5	AGP30148153	PLATE, SEAT MTG 3PT (ISO KIT) (RED)		1
6	AGP05015251	WLDMT, SEAT SLIDE LEVER		1
7	AGP04396600	GRIP, SEAT LEVER, GREY		1
8	AGP08300022	SG-TENS .06X.482X5.35		1
9	AGP07001929	BLT, SHLDR .31-18 X .175		4
10	AGP06500840	NUT,LK-CTR-FLG .31-18 GF ZCC		6
11	AGP07500520	MOUNT, FAIL-SAFE COMPRESSION		3
12	AGP06800120	RIVET, .1875 AL/AL .126-.250		2
13	AGP30135951	WLDMT, ISO MTG PLATE 3PT (BLACK)		1
14	AGP05500901	BSHG, FLG .516X.750X.625X.937		2
15	AGP06800202	PIN, SLIC-.500X42.70X2.31 - ZC		2
16	AGP08300704	SPRING, COMPRESSION SEAT 224LB		2
17	AGP06500828	NUT, COUPLING 5/16X18 X 3.75		2
18	AGP06401108	WSHR, FLT .406X1.00X.188 ZCC		2
19	AGP05901832	BLT, HEX .31-18X.625 G5 ZCC		6
20	AGP06401221	WSHR-FL-STL 0.406X2X0.125 ZCC		3

Ref Number	Part Number	Part Description	Context Notes	Quantity
21	AGP06500901	NUT-LK-CTR-FLG .375-16 GF ZCC		3
22	AGP06514900	NUT-PUSH .312		1
23	AGP06200233	BLT,RHSN .31-18X1.50 G5 ZCC		2
24	AGP06443300	WSHR-FL-NYL .518X1.000X.080		2
25	AGP05265551	GUARD, SEAT FAN (SH) (BLACK)		1
26	AGP21800600	KIT- ZTXL CUSTOM BACK COVER	SERVICE PART	1
27	AGP21800700	KIT- ZTXL CUSTOM SEAT COVER	SERVICE PART	1
28	AGP21800800	KIT- ARMRESTS (CUSTOM PAD)	SERVICE PART	1
29	AGP02754100	SWITCH- SNAP MTG N.O.	SERVICE PART	1

AGU991269 Transaxle Drive

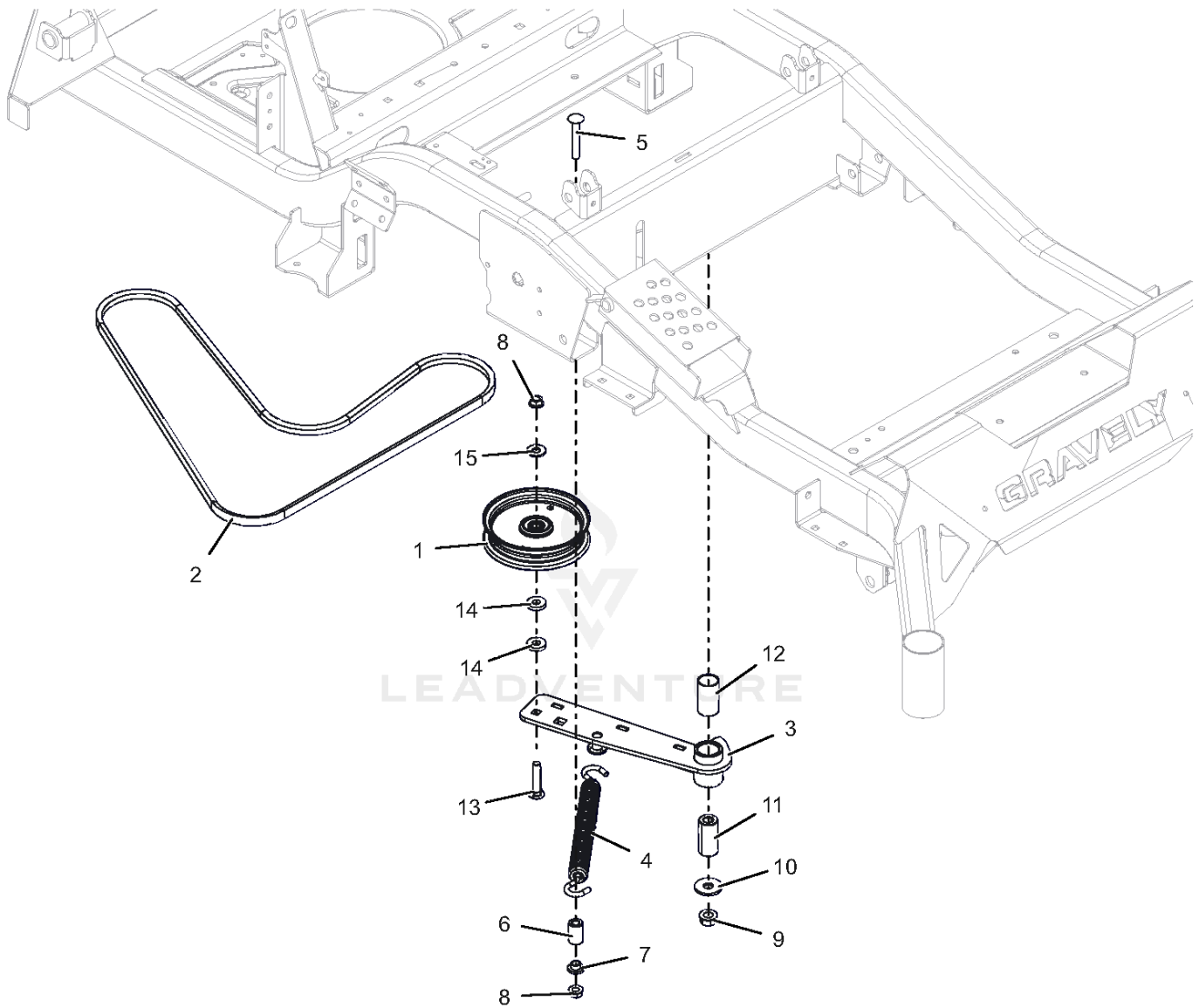

Rendered by LeadVenture, Inc.

AGU991269 Transaxle Drive

Ref Number	Part Number	Part Description	Context Notes	Quantity
1	AGP07351200	IDLER- FLAT - 5.00" X .75"		1
2	AGP07225600	V-BELT, 4L-WRAPPED		1
3	AGP59116700	WLDMT, HYDRO DRIVE IDLER ARM (BLACK)		1
4	AGP08300711	SPRING, EXTENSION		1
5	AGP06200315	BLT, RHSSN.38-16X2.50 G5 ZCC		1
6	AGP05501308	BUSHING, SLV .380X.750X1.190		1
7	AGP05500435	BSHG-FLG .385X.500X.875X.406		1
8	AGP06500822	NUT-LK-TOP-FLG .38-16 ZC120		2
9	AGP06500907	NUT-LK-TOP-FLG .500-13 GF ZCC		1
10	AGP06401022	WSHR-FL- STL.511X1.44X.125ZC120		1
11	AGP01581700	BSHG, SPCR .502X.997X2.03 PM		1
12	AGP05501234	BSHG, 1.00X1.125X1.937		1
13	AGP06200314	BLT, RHSN .38-16X2.00 G5 ZCC		1
14	AGP06401108	WSHR, FLT .406X1.00X.188 ZCC		2
15	AGP06401008	WSHR,FLT .438X1.00X.083 ZCC		1

AGU991269 Wiring Diagram

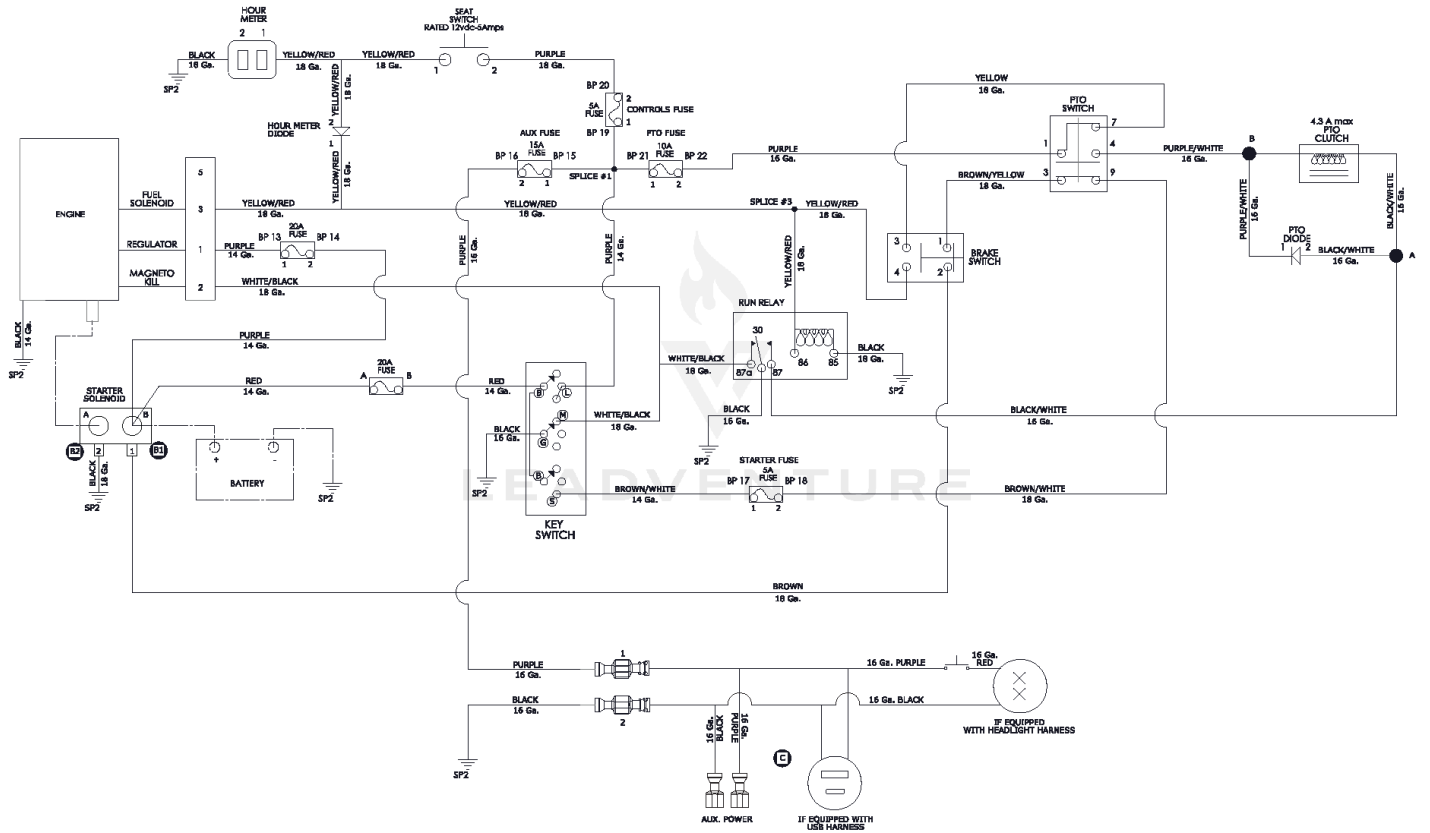

Rendered by LeadVenture, Inc.

AGU991269 Wiring Diagram

Ref Number	Part Number	Part Description	Context Notes	Quantity
-------------------	--------------------	-------------------------	----------------------	-----------------