

# BWM 30 Ton Log Splitter

## User's Manual

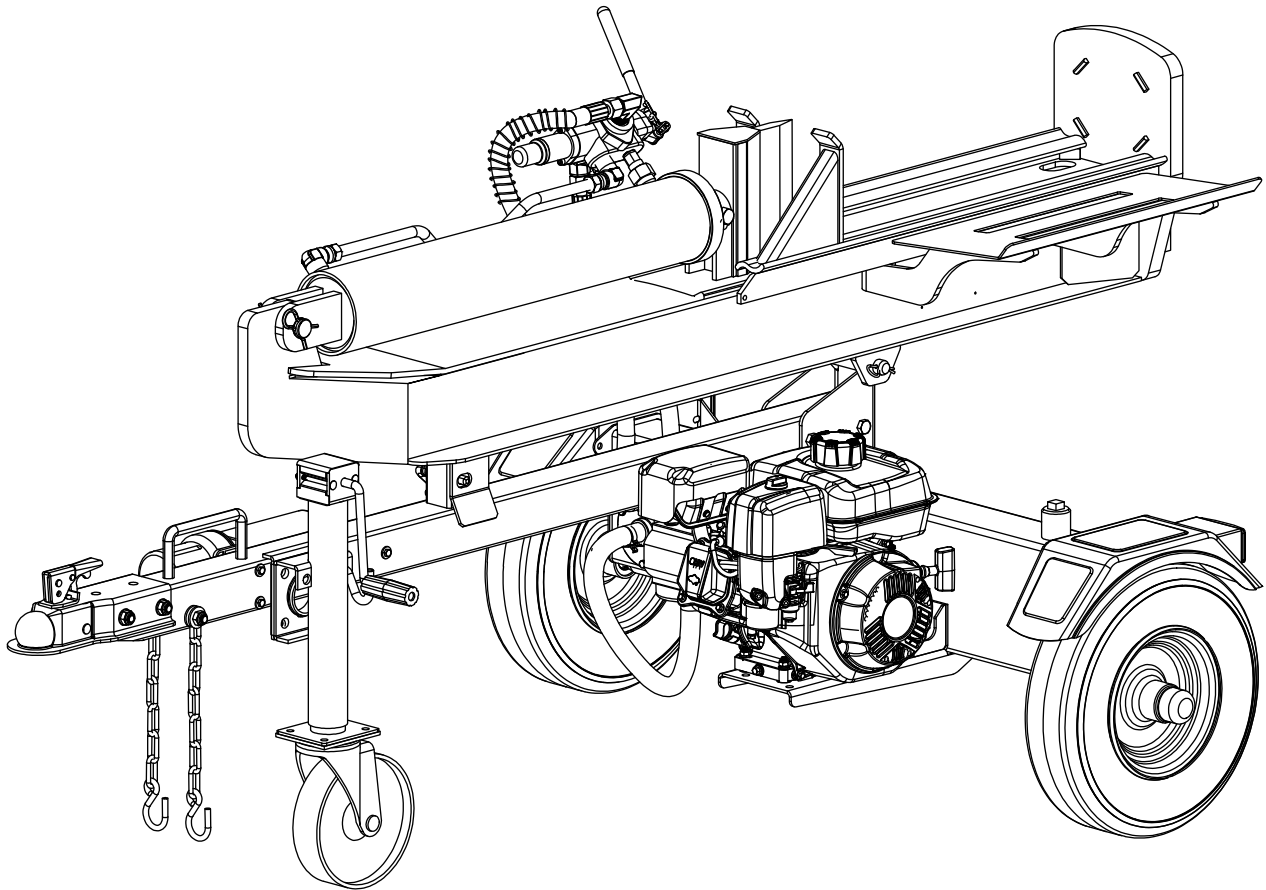

### *BWM LS30 Series*

**Please read through this owner's manual carefully before using the product, to ensure the safety of yourself and others.**

\*Due to continuing improvements, actual product may differ slightly from the product described herein.

# Index

<b>1. General Warnings and Rules.....</b>	<b>3</b>
<b>2. Hazard Signal Definitions .....</b>	<b>4</b>
<b>3. Controls and Features Identification .....</b>	<b>5</b>
<b>4. Assembly Instructions.....</b>	<b>7</b>
<b>5. Operating Instructions.....</b>	<b>13</b>
<b>6. Maintenance and Storage.....</b>	<b>17</b>
<b>7. Troubleshooting.....</b>	<b>18</b>
<b>8. Specifications.....</b>	<b>19</b>
<b>9. Warranty .....</b>	<b>20</b>
<b>10. Illustrated Parts List.....</b>	<b>21</b>



## GENERAL WARNINGS



### **READ and UNDERSTAND this manual completely before using 30 Ton Log Splitter.**

Operator must read and understand all safety and warning information, operating instructions, maintenance and storage instructions before operating this equipment. Failure to properly operate and maintain the log splitter could result in serious injury to the operator or bystanders.

#### **Operation Warnings**

- Do not at any time carry passengers, sit or stand on the log splitter.
- Do not allow children to play on, stand upon or climb on the log splitter.
- Always inspect the log splitter before using to assure it is in good working condition.
- Replace or repair damaged or worn parts immediately.
- Always check and tighten hardware and assembled parts before operation.
- Do not exceed equipment maximum load capacity of 30 tons.
- Avoid large holes and ditches when towing the equipment.
- Always operate the log splitter on clear and level ground.
- Do not operate the log splitter at night, only during daylight hours.
- Always tow at reduce speed in rough terrain, along creeks, ditches and on hillsides.
- To avoid personal injury and/or equipment damage **DO NOT EXCEED 72 KM/H.**
- Always refer to the vehicle owner's manual for proper towing.
- Always secure and lock the log splitter to the vehicle hitch before towing.

#### **Crush and Cut Hazards**

- Always keep hands and feet clear from moving parts while operating the equipment.
- Always clear and keep work area clean and free of debris when operating.
- Always wear safety gear, eye protection, gloves and work boots when operating the log splitter.







### **WARNING**

The warnings, cautions, and instructions outlined in this instruction manual cannot cover all possible conditions or situations that may occur. It must be understood by the operator that common sense and caution are factors which cannot be built into this product and must be supplied by the operator.

#### **Assembly Is Required**

This product requires assembly before use. See "Assembly" section for instructions. Because of the weight and/or size of the log splitter, it is recommended that another adult be present to assist with the assembly. **INSPECT ALL COMPONENTS** closely upon receipt to make sure no components are missing or damaged.

# Hazard Signal Word Definitions

	<p>This is the safety alert symbol. It is used to alert you to potential personal injury hazards. Obey all safety messages that follow this symbol to avoid possible injury or death.</p>
	<p><b>DANGER</b> indicates an imminently hazardous situation which, if not avoided, will result in death or serious injury.</p>
	<p><b>WARNING</b> indicates a potentially hazardous situation which, if not avoided, could result in death or serious injury.</p>
	<p><b>CAUTION</b> indicates a potentially hazardous situation which, if not avoided, may result in minor or moderate injury.</p>
	<p><b>CAUTION</b> used without the safety alert symbol indicates a potentially hazardous situation which, if not avoided, may result in property damage.</p>

## ABOUT YOUR 30 TON LOG SPLITTER

This hydraulic log splitter has a heavy-duty steel construction and 30 tons of ram force. When there's work to be done, you need outdoor power equipment you can rely on, this log splitter will get the job done fast. It is designed to work in both the horizontal and vertical position. It is easy to tow, easy to use and maintain. Never exceed the rated capacity of 30 tons when operating the log splitter.

Technical specifications on the log splitter are provided in the "Specifications" section of this manual.

# Controls and Features Identification

Read this owner's manual before operating the equipment. Familiarize yourself with the location and function of the controls and features. Save this manual for future reference.

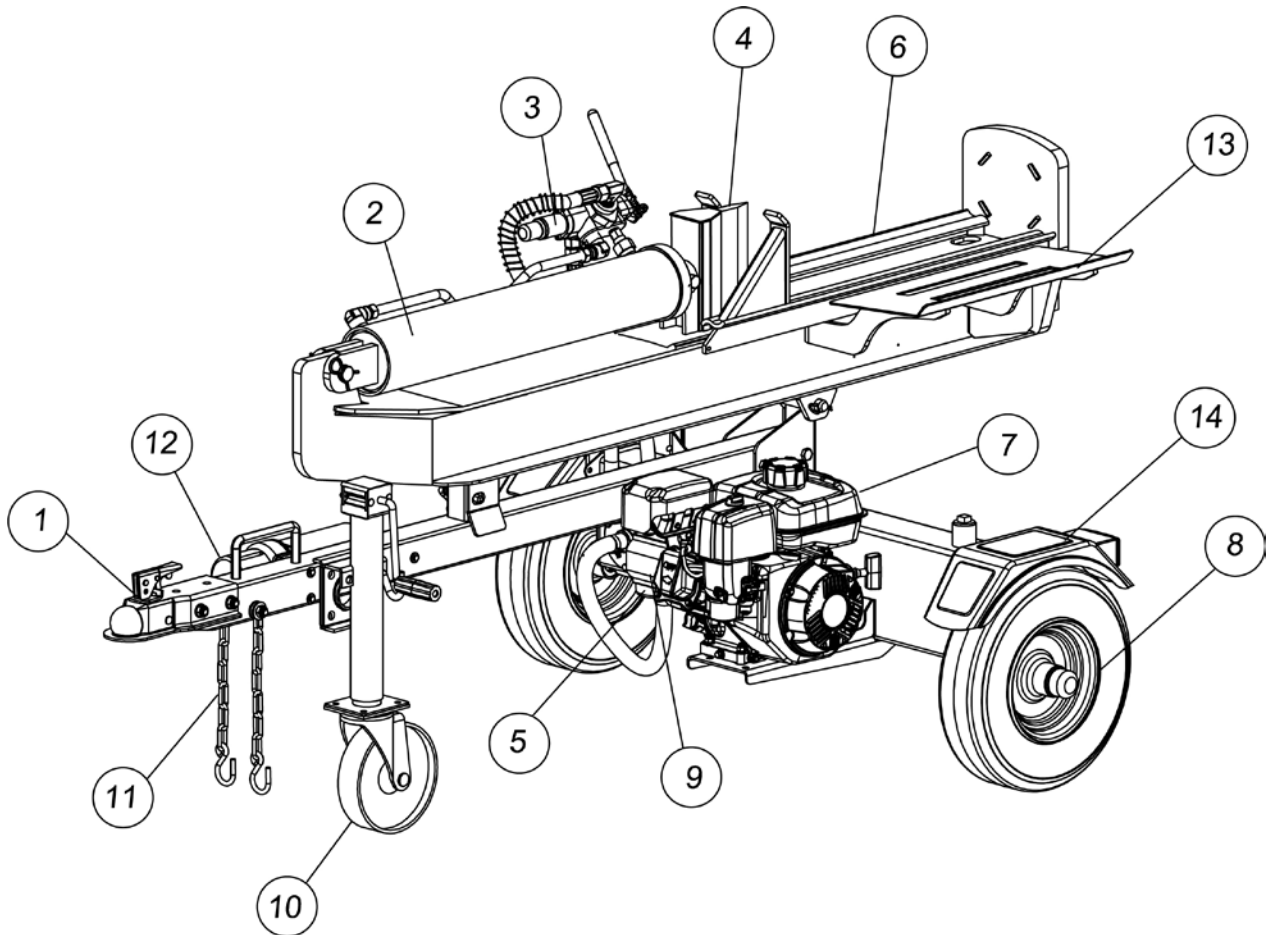

1. **2" Coupler** – Attaches the log splitter to the 2" ball
2. **Hydraulic Cylinder** – 4.5" x 24.5", rated to 3500 psi.
3. **Control Valve** – Controls the forward and backward movement of splitting wedge.
4. **8" Wedge**
5. **Spin-on Filter**
6. **Beam**
7. **Engine** – Air cooled engine powers the hydraulic pump.
8. **Tyres** – Maximum rated towing speed is 72 KM/H.
9. **Gear Pump** – Pumps the hydraulic oil through the system.
10. **Jockey Wheel**
11. **Safety Chains** – Safety feature to prevent loss of log splitter while towing.
12. **Manual Canister** – Storage for Owner's Manual and small tools.
13. **Log Table** – Holds a split log until you are ready to split again.
14. **Fenders**

 **WARNING**

Read and follow all instructions for assembly and operation. Failure to properly assemble this equipment could result in serious injury to the user or bystanders, or cause equipment damage.



**Engine Shipped Without Oil.**

Before starting engine, fill with SAE 10W-30 motor oil or Honda 10W30 engine oil, depending on your model.  
See engine manual for engine oil capacity.

**Hydraulic Oil Tank is Shipped Without Oil.**

When adding oil verify the oil level reads 1 from the top of hydraulic oil tank if marking is not shown fill to the neck.

**Inspect all Log Splitter Components.**

If you have damaged components: Contact the freight company that delivered the log splitter and file a claim.

# Assembly Instructions

## 30 TON LOG SPLITTER ASSEMBLY

Set the shipping crate on a solid flat surface and carefully remove the lid. Use two people and take all parts out of the shipping crate and inspect the components to ensure there are no missing pieces before starting to assemble the log splitter follow steps 1 through 8.

### TOOLS REQUIRED

- Rubber or Wooden Hammer
- 13mm, 16mm, 17mm, 18mm, 19mm, 24mm, 27mm Wrenches
- Large Adjustable Wrench
- Phillips or Standard Screwdriver
- Pliers

### STEP 1: Wheel Assembly

1. Attach the wheel (#35) to the oil tank axle (#44) using a conical roller bearing (#81), flat washer  $\text{\O}20$  (#70) and tighten the wheel with the hex slotted nut M20 (#37). Lock the hex slotted nut M20 (#37) in place using the cotter pin  $\text{\O}4 \times 36$  (#73). Install the axle cap (#41) on the end using rubber hammer.

**Note:** flat washer  $\text{\O}20$  (#70), hex slotted nut M20 (#37) and cotter pin  $\text{\O}4 \times 36$  (#73) are already on tank axle (#44), need take out then to assemble. Make sure bearings (#81) and oil seal (#80) assembled inside of the wheel (#35). After tightening the slotted nut, loosen nut 1/4 of a turn so the tyre will rotate freely. Failure to loosen the nut may cause excessive bearing and tyre wear.

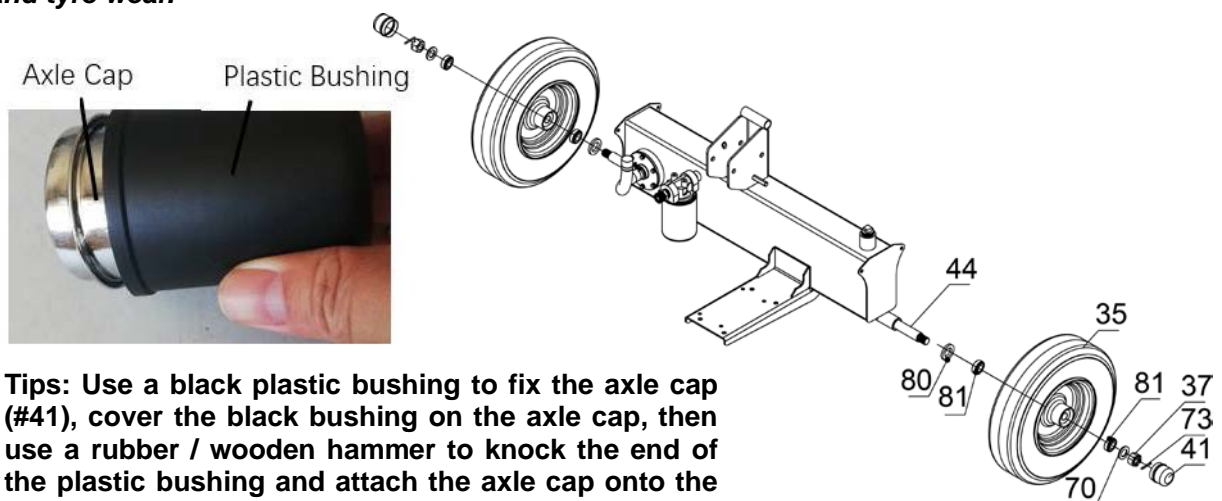

**Tips:** Use a black plastic bushing to fix the axle cap (#41), cover the black bushing on the axle cap, then use a rubber / wooden hammer to knock the end of the plastic bushing and attach the axle cap onto the wheel.

## STEP 2: Attach Tow Bar to the Oil Tank

1. Attach the tow bar (#59) to the oil tank and secure using two sets of hex bolts M12x100 (#24), flat washers Ø12 (#62) and nylon lock nuts M12 (#13).

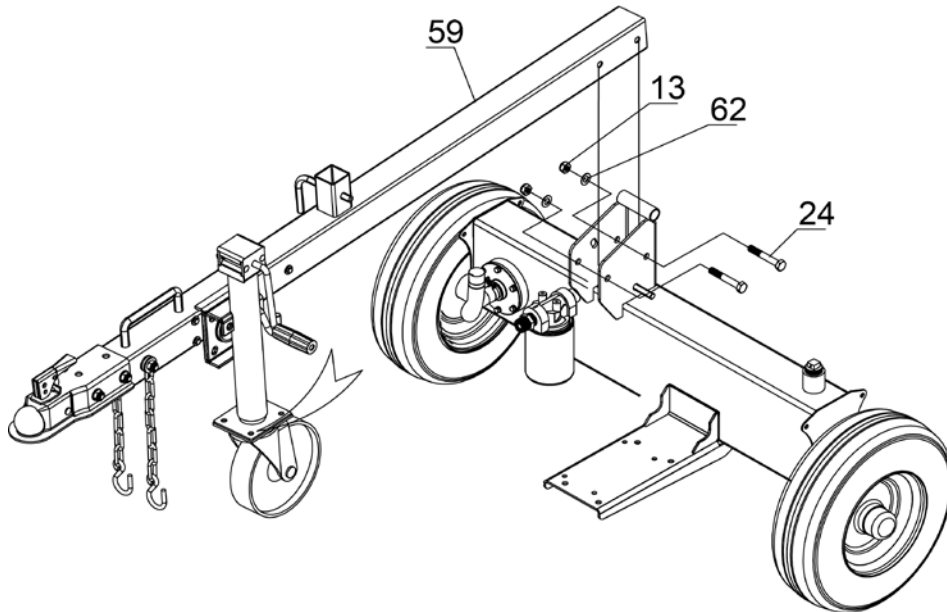

## STEP 3: Attach the Beam Assembly

1. Attach the beam assembly (#17) to the oil tank and secure using the hitch pin (#18) and R pin (#21).

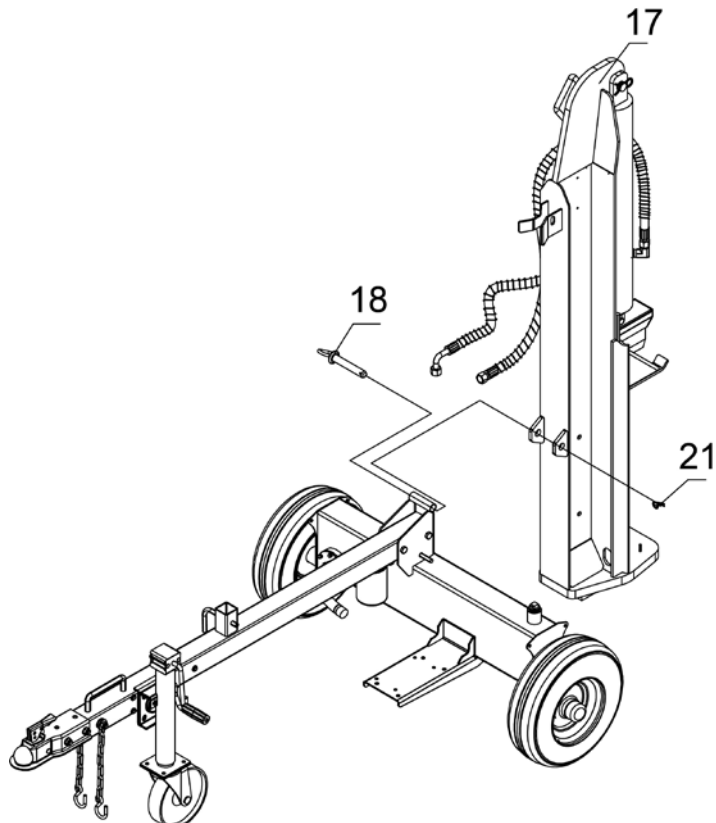



## STEP 4: Attach the Engine (Assembled in Australia Factory)

1. Place four sets of polyurethane blocks (#71) and large flat washers  $\text{\O}10$  (#72) on the mounting plate.
2. Position the engine (#33) over the blocks and washers, secure it to the mounting plate, put the hex bolts M8x65 (#46) through the bottom of the plate (bolts should go through blocks, flat washers and engine base). Place four sets of flat washers  $\text{\O}8$  (#36), lock washers  $\text{\O}8$  (#32) and tighten with nylon lock nuts M8 (#31) and tighten with nylon lock nuts M8 (#31).
3. Attach the clear oil pipe (#53) to the bottom of the gear pump and secure with clamp (#51).

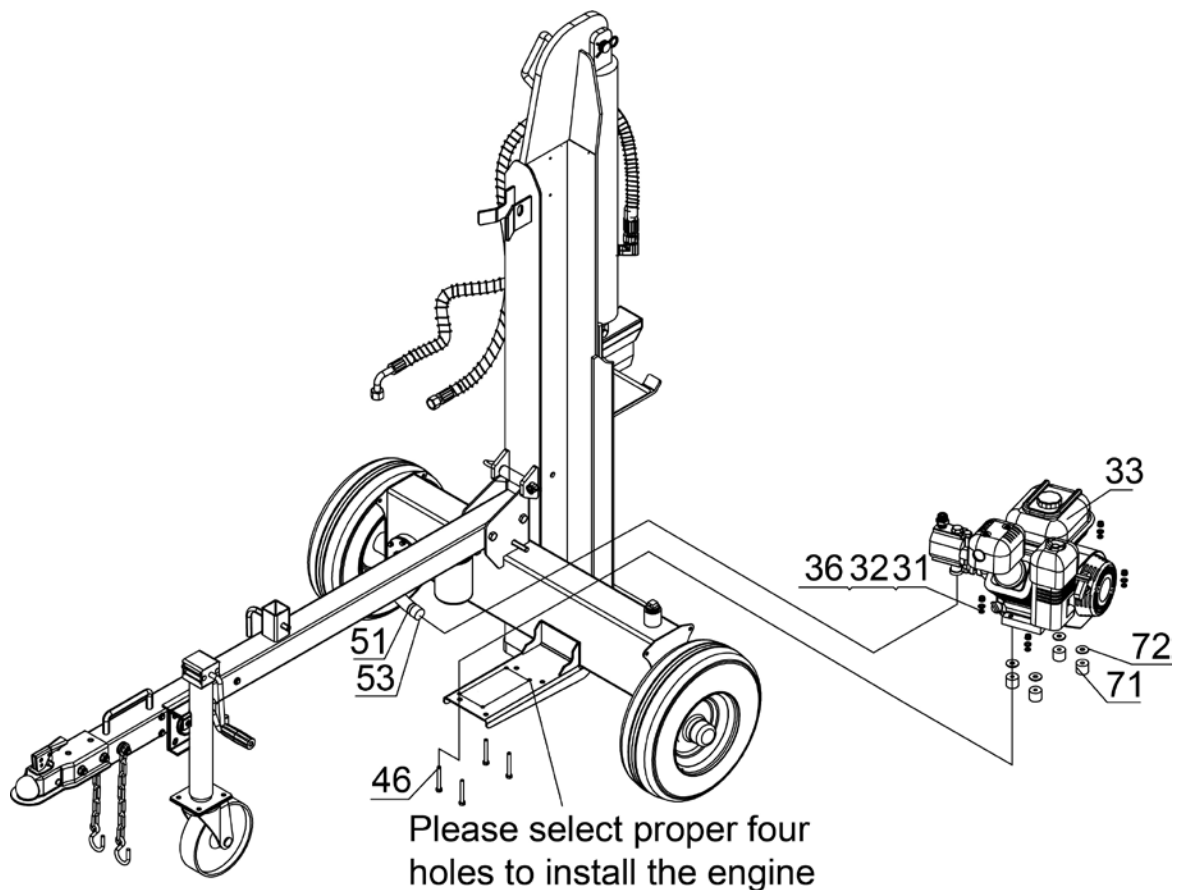

## STEP 5: Attach Hydraulic Hoses, Manual Canister, Log Cradle and Fenders

1. Put O ring Ø11x2.5 (#19) on the gear pump outlet connector (#23), attach the hydraulic hose (#16) to the gear pump outlet connector (#23).
2. Put O ring Ø17x2.5 (#68) on the spin-on filter connector (#50), attach the hydraulic hose (#7) to the connector (#50).
3. Remove the three sets of hex bolts M6x90 (#75), large flat washers Ø6 (#76) and nylon lock nuts M6 (#77) from the tow bar. Attach the manual canister (#74) to the tow bar by reinstalling items 75, 76 and 77.
4. Attach the log cradle (#64) to the beam using two sets of hex bolts M12x35 (#82), flat washers Ø12 (#62) and nylon lock nuts M12 (#13).
5. Attach the fenders (#85 & #86) to the oil tank using four sets of hex bolts M8x25 (#83), rubber washers (#84), flat washers Ø8 (#36), lock washers Ø8 (#32) and nylon lock nuts M8 (#31).
6. Remove the spring cotter pin and the retaining pin from the control valve. Rotate the control lever to the vertical position and secure with the retaining pin and the spring cotter pin.

**Note: Please put a rubber washer (#84) between fender and oil tank.**

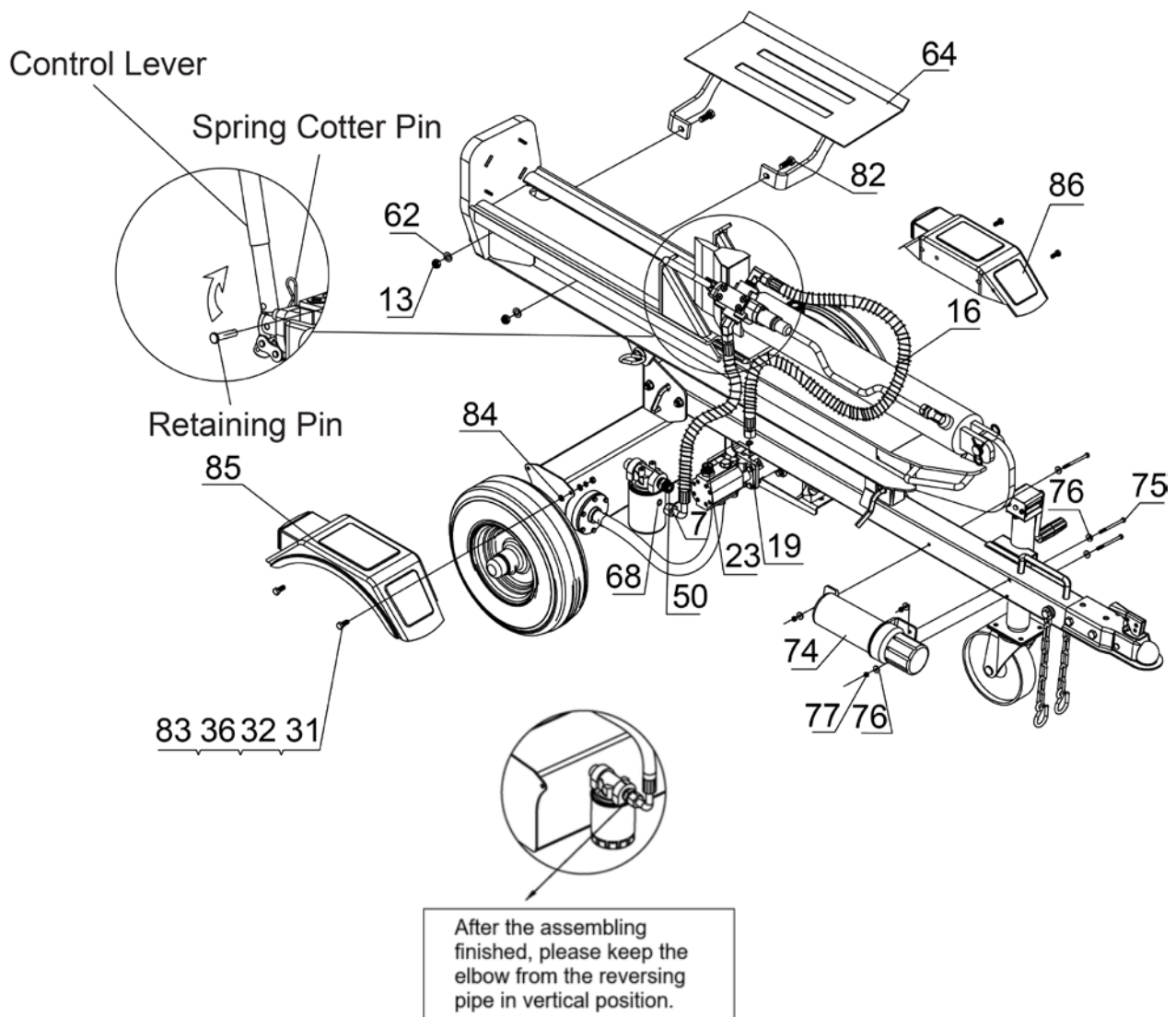

## STEP 6: Add Engine Oil

1. Make sure the log splitter is on a level surface.
2. Unscrew the oil fill cap/dipstick to add oil.
3. Refer to owner's engine manual for the amount needed for engine oil (SAE30 or 10W30, depending on your model); replace the oil fill cap/dipstick.
4. Check engine oil level daily and add as needed.

**NOTE: During the break-in period check the engine oil level more often.**

### CAUTION

DO NOT attempt to crank or start the engine before it has been properly filled with the recommended type and amount of oil. Damage to the log splitter as a result of failure to follow these instructions will void your warranty.

## STEP 7: Add Fuel to the Engine

1. Use only clean, fresh, regular unleaded 91 fuel.
2. DO NOT mix oil with fuel.
3. Remove the fuel cap and slowly add fuel to the tank. DO NOT overfill, allow approximately ¼ inch of space for fuel expansion.
4. Screw on the fuel cap and wipe away any spilled fuel.



### DANGER

Log splitter engine exhaust contains carbon monoxide, a colorless, odorless, poison gas. Breathing carbon monoxide will cause nausea, dizziness, fainting or death. If you start to feel dizzy or weak, get to fresh air immediately.

Operate log splitter outdoors only in a well ventilated area.

DO NOT operate the log splitter inside any building, enclosure or compartment.

DO NOT allow exhaust fumes to enter a confined area through windows, doors, vents or other openings.

**DANGER: CARBON MONOXIDE**, using a log splitter indoors **CAN KILL YOU IN MINUTES.**



### CAUTION

Fuel and fuel vapors are highly flammable and extremely explosive.

Fire or explosion can cause severe burns or death.

Unintentional startup can result in entanglement, traumatic amputation or laceration.

Only use regular unleaded 91 fuel.

DO NOT mix oil and petrol together.

Fill tank approximately ¼" below the top of the tank to allow for fuel expansion.

DO NOT fill fuel tank indoors or when the engine is running or hot.

DO NOT light cigarettes or smoke when filling the fuel tank.

## STEP 8: Add Hydraulic Oil

1. The log splitter needs to be on a flat, level surface before adding the hydraulic oil.
2. Remove the oil cap from the hydraulic oil tank.
3. Add 12 liters of AW46 hydraulic oil.
4. Check the hydraulic oil level.
5. Start engine and use the control lever to extend and retract wedge several times to remove air from the lines.

6. With the wedge retracted, check hydraulic oil level again and fill if necessary.



## WARNING

DO NOT remove the hydraulic oil fill cap when the engine is running or hot. Hot oil can escape causing severe burns. Always allow the log splitter to cool completely before removing the hydraulic oil cap.

High fluid pressure and temperatures are created in the hydraulic log splitters. Hydraulic fluid will escape through a pin-size hole opening and can puncture skin and cause severe blood poisoning.

Inspect hydraulic system regularly for possible leaks. **Never check for leaks with your hand while the system is pressurized. Seek medical attention immediately if injured by escaping fluid.**

Make sure all fittings are tight and secure before applying pressure. Relieve system pressure before servicing.

Make sure the hydraulic hoses do not touch any hot surfaces or cutting areas.

Hoses need to be positioned where they are clear from the engine and cutting wedge. To avoid serious bodily injury always inspect the hoses before operating the log splitter.

# Operating Instructions

## WARNING

Before operating or using the log splitter, review the instructions below and all safety information. Failure to follow these instructions may result in property damage or injury to the operator or bystanders

## WARNING

**ALWAYS** use the log splitter for its intended use.  
**ONLY** use the log splitter to split wood logs, length wise with the grain.  
**NEVER** modify, alter or change the log splitter in anyway, modifications will void the warranty.  
**NEVER** attach a rope, cable or other device to the control lever on the log splitter.  
**ONLY** operate the log splitter in daylight.  
**NEVER** leave the log splitter unattended while the engine is running.  
**DO NOT** change the splitting position with the engine running. Contact with the muffler can cause serious burns.  
**ALWAYS** make sure the beam is in the locked position.  
**DO NOT** let the beam drop as it could crush fingers or cause damage to the log splitter.  
**NEVER** operate or let anyone else operate, the log splitter while under the influence of alcohol, drugs, or medication.

## USING YOUR LOG SPLITTER

1. DO NOT at any time carry passengers, sit or stand on the log splitter.
2. Check the hydraulic oil level and visually inspect all hoses and attachments for problems.
3. Inspect the engine and make sure the engine oil level is correct.
4. Before towing the log splitter the tyres need to be fully inflated.

## TYRE WARNING

DO NOT over inflate tyres. Serious injury can result if tyres explode.  
DO NOT tow the log splitter if the tyres are worn or will not hold air.  
DO NOT exceed the maximum 72 KM/H towing speed.

5. Refer to the vehicle owner's manual for proper safety and towing instructions.

## TOWING WARNING

Serious injury or death can occur if towing safety rules are not followed.  
Always use safety chains, secure and lock the log splitter to the vehicle hitch before moving.  
Drive safely. Be aware of the added length of the log splitter.  
Never exceed the maximum travel speed of 72 KM/H.  
Never ride or transport cargo on the log splitter.  
Turn off the vehicle before leaving the log splitter unattended.  
Block the log splitter wheels to prevent unintended movement.

6. The log splitter must have at least 2 meters of clearance from combustible material. It needs to be on a dry and level surface with good footing. Do not work on mud, ice, brush or snow. When using the log splitter the work zone must be maintained at all times.

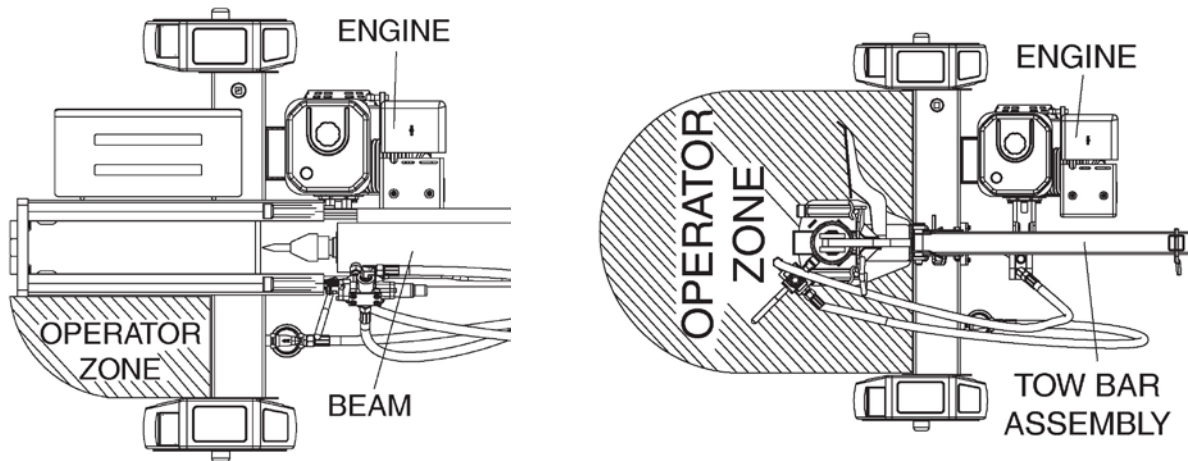

**NOTE: Serious accidents can happen when other people are allowed inside the work zone. Keep everyone else outside the work zone while operating the control lever.**

7. Always wear safety gear, eye protection, gloves and work boots when operating the log splitter.
8. Start the engine and make sure the log splitter is on level ground before operating.

**NOTE: The hydraulic oil needs to be above -12C° before starting the engine. Cold hydraulic oil can damage the hydraulic pump. If outdoor air temperature is below 0C° allow the log splitter to warm up by extending and returning the wedge several times before splitting wood.**

9. Put the support leg in the down position to prevent the log splitter from moving during operation and block both tyres.
10. Set the log splitter in either the horizontal or vertical position.

**NOTE: HORIZONTAL position is used for lighter logs that can easily be loaded onto the beam. The VERTICAL position is used for either light logs or heavy logs that are difficult to load onto the beam. Back injury can result from lifting logs onto the log splitter if proper lifting techniques are not used.**

11. Load a log onto the beam against the endplate (Max Log Length-26”).

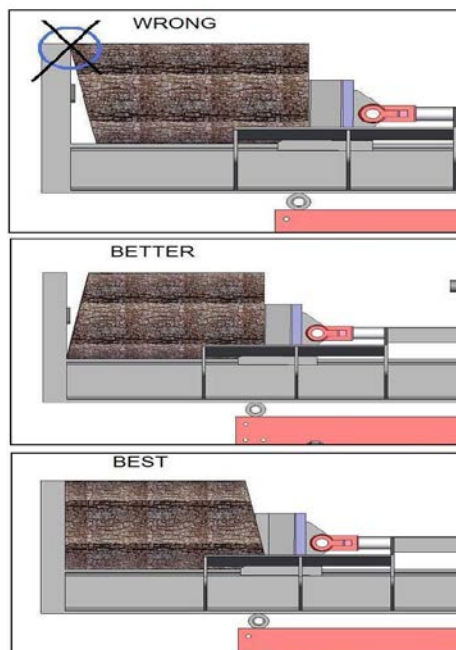

12. Make sure hands are clear from the wedge and crush hazard areas.



### **CRUSH WARNING**

Wedge can cut through skin and break bones. Keep both hands away from wedge and beam slide. Serious accidents can happen when other people are allowed inside the work zone. Keep everyone else out of the work zone while operating control lever.

DO NOT wear loose clothing. It can get tangled in moving parts of log splitter.

Only use the log splitter in daylight so you can see what you are doing.

13. Push control lever FORWARD by one hand to split the log.

14. Push control lever BACKWARD by one hand to return wedge to its original position.



### **CAUTION**

If a log gets stuck, embedded or will not split completely, push the control lever in the reverse direction and allow the splitter to strip the log from the wedge.

If the log still remains stuck, embedded or will not split, turn the machine off and use a sledge hammer and crow bar to remove the log.

ALWAYS keep hands clear of the log and wedge while it is retracting.

15. Always keep work zone clean and free of split wood and debris.

# Operating Instructions

## HORIZONTAL POSITION

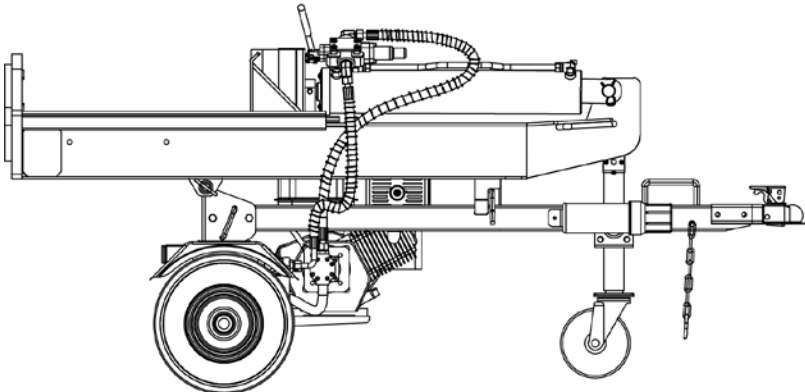

## VERTICAL POSITION

1. Pull beam lock pin.
2. Rotate the beam in the upright position by lifting the beam.

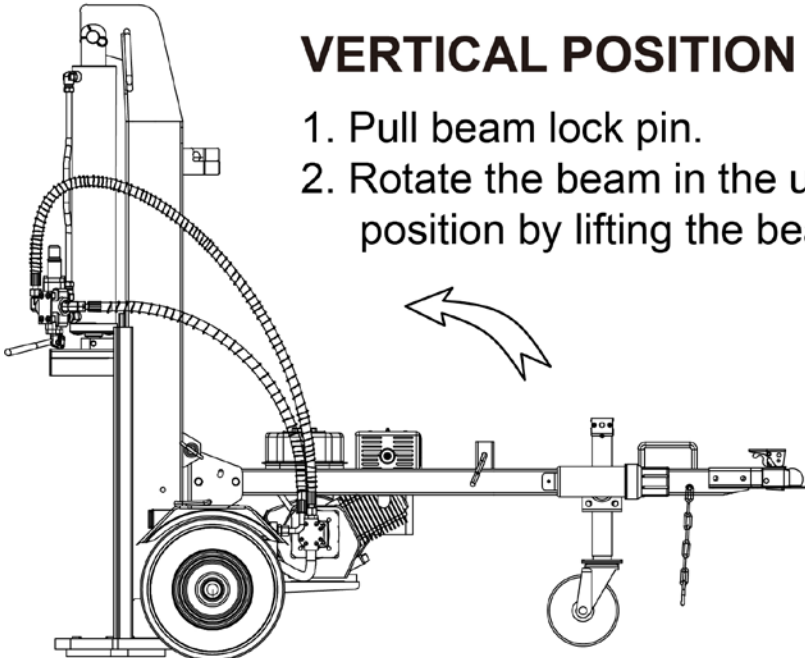

Upright position for splitting large logs.

## FOR VEHICLE TOWING

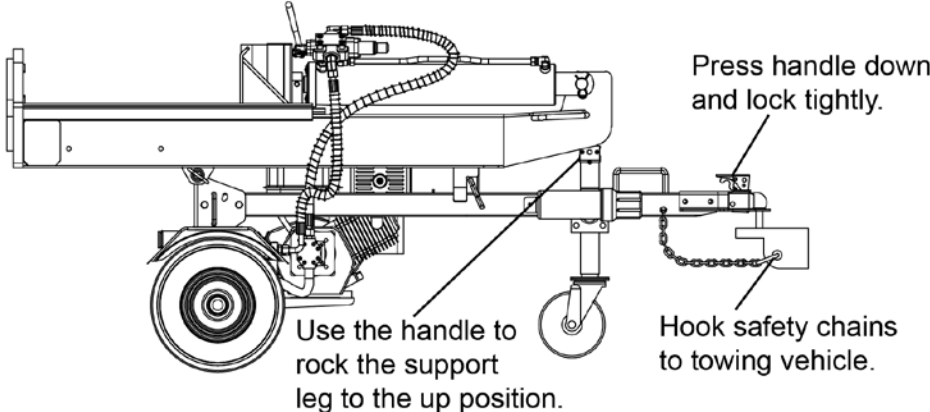

Use the handle to rock the support leg to the up position.

Press handle down and lock tightly.

Hook safety chains to towing vehicle.



# Maintenance and Storage

## CAUTION

Improper maintenance and storage of the log splitter may void your warranty.

## MAINTENANCE

- Before performing any maintenance, the log splitter must be placed in maintenance mode. Turn off the engine and move the control lever forward and backwards to relieve the hydraulic pressure.
- After performing any maintenance, make sure all guards, shields and safety features are put back in place before operating the log splitter.
- Before operating make sure the tyres have the RECOMMENDED TYRE PRESSURE.
- Regularly grease axle and wheel bearing area or when needed.
- Periodically check all fasteners and hoses for tightness and leaks.
- Annually clean and lightly lubricate all moving parts or when needed.
- Use a glossy enamel spray paint to touch up scratched or worn painted metal surfaces.
- Never exceed load capacity rating of 30 tons it will damage the log splitter.

What	When	How
Hoses	Each Use	Inspect hoses for exposed wire mesh and leaks. Replace all worn or damaged hoses before starting the engine.
Hydraulic Fittings	Each Use	Inspect fittings for cracks and leaks. Replace all damaged fittings before starting the engine.
Nuts and Bolts	Each Use	Check for loose bolts, tighten before operating.
Beam	Each Use	Apply grease to beam surface.
Moving Parts	Each Use	Clear debris from log splitter.

**Refer to the Engine Owner's Manual for engine maintenance.**

### **IMPORTANT:**

If a part needs replacement, only use parts that meet the manufacturer's specifications. Replacement parts that do not meet specifications may result in a safety hazard or poor operations.

## STORAGE

- Before storing make sure the log splitter is clean and dry for years of trouble-free service.
- Lightly lubricate all log splitter surfaces and moving parts to prevent rust.
- Store indoors or protected area during severe weather and winter months.

# Troubleshooting

<b>Problem</b>	
Cylinder rod will not move	SOLUTION: A,D,E,H,J
Slow cylinder rod speed when extending or retracting	SOLUTION: A,B,C,H,I,K,L
Wood will not split or splits extremely slowly	SOLUTION: A,B,C,F,I,K
Engine bogs down during splitting	SOLUTION: G,L
Engine stalls under low load condition	SOLUTION: D,E,L,M
Engine starts problem	SOLUTION: N
<b>Cause</b>	<b>Solution</b>
<b>A</b> -Insufficient oil to pump	Check oil level in reservoir
<b>B</b> -Air in oil	Check oil level in reservoir
<b>C</b> -Excessive pump inlet vacuum	Check pump inlet hose for blockage or kinks
<b>D</b> -Blocked hydraulic lines	Flush and clean the splitter hydraulic system
<b>E</b> -Blocked control valve	Flush and clean the splitter hydraulic system
<b>F</b> -Low control valve setting	Adjust control valve with a pressure gauge
<b>G</b> -High control valve setting	Adjust control valve with a pressure gauge
<b>H</b> -Damaged control valve	Return control valve for authorized repair
<b>I</b> -Internal control valve leak	Return control valve for authorized repair
<b>J</b> -Internal cylinder leak	Return cylinder for authorized repair
<b>K</b> -Internally damaged cylinder	Return cylinder for authorized repair
<b>L</b> -Engine Control out of adjustment	Adjust idle control nuts
<b>M</b> -Engine is loaded during idle down mode	Use shorter log length (26" or less) to allow engine to speed up before contact.
<b>N</b> -Engine operation	Refer to the Engine Owner's Manual

## Specifications

Ram Force .....	30 Ton
Cycle Time .....	12 Sec
Wedge Size.....	8” Hardened Steel
Max. Log Length .....	26”
Gear Pump.....	2-Stage
Hydraulic Oil.....	AW46 Hydraulic Oil
Hydraulic Cylinder.....	4.5” x 24.5”
Max. Pressure.....	3500 PSI
Max. Flow .....	14 GPM
Wheel Size.....	16” / 4.80-8
Hitch Type.....	2” Ball Coupler
Max. Towing Speed.....	72 KM/H
Engine.....	HONDA GX200, HONDA GP200 or Briggs & Stratton 6.5HP

***NOTE: For Engine Details Refer to the Engine Owner’s Manual.***

# Warranty

## **Limited Warranty**

The warranty period for the log splitter is 2 years (Domestic use) and 1 year (commercial use) from the purchase date. The engine has a 3 year warranty. The warranty will not apply to any unit which was not assembled correctly, misused, overloaded or which has been used or operated contrary to our instructions, or which has been repaired or altered by anyone other than an authorized representative.

## **Warranty Exclusions**

Warranty will not cover:

- Pieces worn out due to normal wear and tear.
- Misuse, negligence of care, and lack of maintenance.
- Failures due to using non genuine replacement parts.

Warranty will be voided if the machine has been modified in any way.

# Parts Illustration List

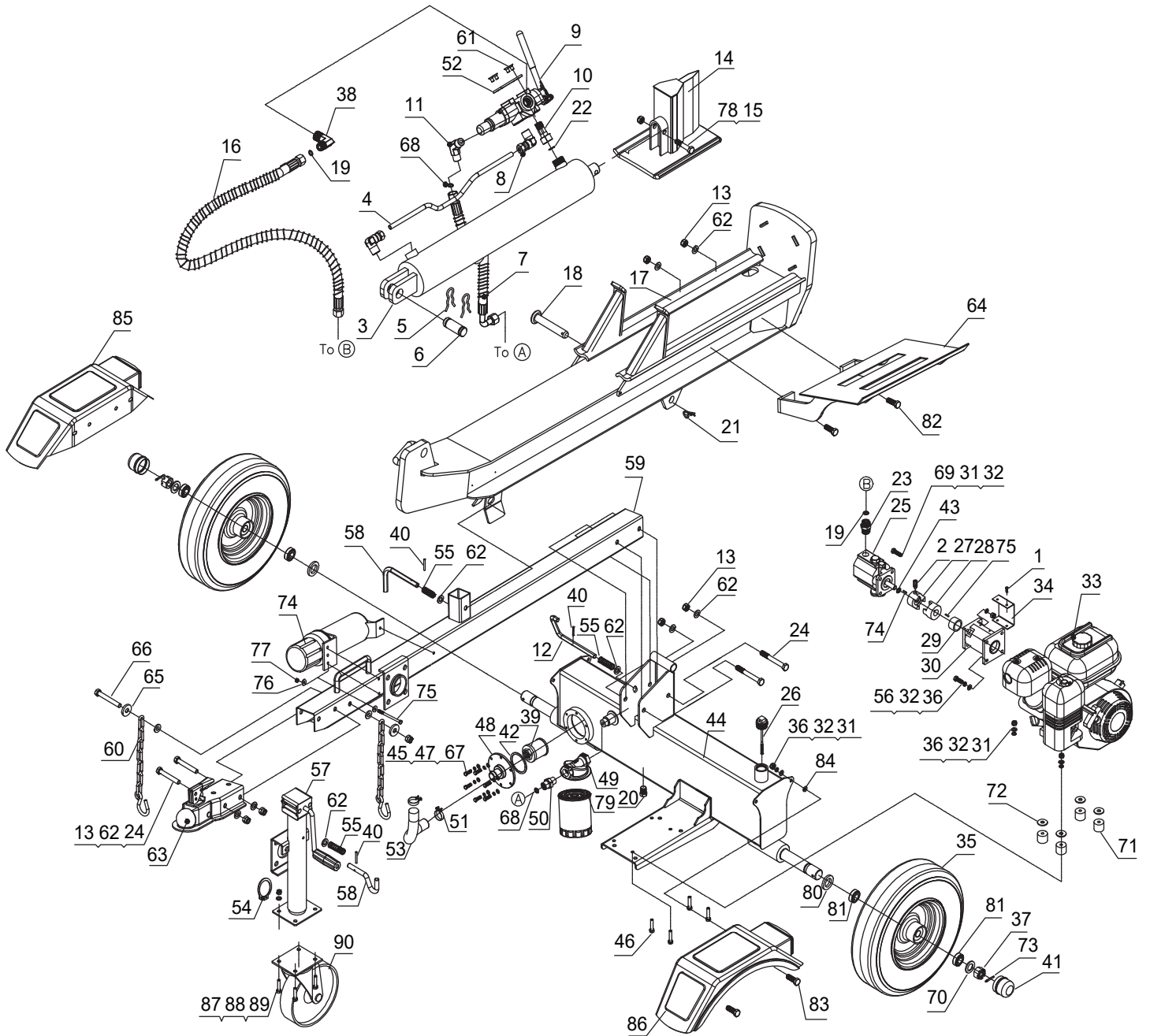

## Parts Illustration List

Ref #	Part No.	Description	Qty
1	BWMLS300001	Hex Bolt M5x10	4
2	BWMLS300002	Inner Hex Cone Point Set Screw M6x10	1
3	BWMLS300003	Cylinder	1
4	BWMLS300004	Metal Hydraulic Hose	1
5	BWMLS300005	R Pin Ø4.5	2
6	BWMLS300006	Cylinder Pin	1
7	BWMLS300007	Hydraulic Hose (Valve - Spin-on Filter)	1
8	BWMLS300008	Cutting Sleeve Connector	2
9	BWMLS300009	One-Way Single Handle Control Valve	1
10	BWMLS300010	Combination Connector	1
11	BWMLS300011	130° Joint	1
12	BWMLS300012	Safety Pin	1
13	BWMLS300013	Nylon Lock Nut M12	7
14	BWMLS300014	Wedge	1
15	BWMLS300015	Hex Bolt M14x85	1
16	BWMLS300016	Hydraulic Hose (Valve - Pump)	1
17	BWMLS300017	Beam Assembly	1
18	BWMLS300018	Hitch Pin	1
19	BWMLS300019	O Ring Ø11x2.5	2
20	BWMLS300020	Oil Plug	1
21	BWMLS300021	R Pin Ø3	1
22	BWMLS300022	O Ring Ø15x2.5	1
23	BWMLS300023	Pump Outlet Connector	1
24	BWMLS300024	Hex Bolt M12x100	4
25	BWMLS300025	Gear Pump 13/1.8	1
26	BWMLS300026	Oil Bolt	1
27	BWMLS300027	Gear Pump Coupler	1
28	BWMLS300028	Engine Coupler	1
29	BWMLS300029	Engine Bushing	1
30	BWMLS300030	Gear Pump Stand	1
31	BWMLS300031	Nylon Lock Nut M8	12
32	BWMLS300032	Lock Washer Ø8	16
33	BWMLS300033	Engine (Honda GX200, Honda GP200, or Briggs & Stratton 6.5HP)	1
34	BWMLS300034	Coupler Cover	1
35	BWMLS300035	Wheel Assembly	2
36	BWMLS300036	Flat Washer Ø8	12

Ref #	Part No.	Description	Qty
37	BWMLS300037	Thin Hex Slotted Nut M20	2
38	BWMLS300038	Angle Connector	1
39	BWMLS300039	Oil Filter	1
40	BWMLS300040	Cotter Pin Ø3x30	3
41	BWMLS300041	Axle Cap	2
42	BWMLS300042	Rubber Washer	1
43	BWMLS300043	Wire Snap rings for shaft	1
44	BWMLS300044	Oil Tank	1
45	BWMLS300045	Flat Washer Ø6	6
46	BWMLS300046	Hex Bolt M8x65	4
47	BWMLS300047	Hex Bolt M6x20	6
48	BWMLS300048	Filter Mounting Plate	1
49	BWMLS300049	Aluminum Seat	1
50	BWMLS300050	Connector	1
51	BWMLS300051	Clamp	2
52	BWMLS300052	Plate	1
53	BWMLS300053	Oil Pipe	1
54	BWMLS300054	Wire Snap rings for shaft Ø62	1
55	BWMLS300055	Spring	3
56	BWMLS300056	Hex Bolt M8x25	4
57	BWMLS300057	Hand-cranked Support Leg	1
58	BWMLS300058	Safety Pin	2
59	BWMLS300059	Tow Bar	1
60	BWMLS300060	Chain Assembly	2
61	BWMLS300061	Cross Screw M8x10	4
62	BWMLS300062	Flat Washer Ø12	11
63	BWMLS300063	2" Coupler	1
64	BWMLS300064	Log Cradle	1
65	BWMLS300065	Thick Washer	2
66	BWMLS300066	Hex Bolt M12x110	1
67	BWMLS300067	Lock Washer Ø6	6
68	BWMLS300068	O Ring Ø17x2.5	2
69	BWMLS300069	Hex Bolt M8x30	4
70	BWMLS300070	Flat Washer Ø20	2
71	BWMLS300071	Polyurethane Block	4
72	BWMLS300072	Large Flat Washer Ø10	4
73	BWMLS300073	Cotter Pin Ø4x36	2
74	BWMLS300074	Manual Canister	1
75	BWMLS300075	Hex Bolt M6x90	3

Ref #	Part No.	Description	Qty
76	BWMLS300076	Large Flat Washer Ø6	6
77	BWMLS300077	Nylon Lock Nut M6	3
78	BWMLS300078	Nylon Lock Nut M14	1
79	BWMLS300079	Spin-on Filter	1
80	BWMLS300080	Oil Seal	2
81	BWMLS300081	Conical Roller Bearing	4
82	BWMLS300082	Hex Bolt M12x35	2
83	BWMLS300083	Hex Bolt M8x25	4
84	BWMLS300084	Rubber Washer	4
85	BWMLS300085	Left Fender	1
86	BWMLS300086	Right Fender	1
87	BWMLS300087	Hex Bolt M10x25	4
88	BWMLS300088	Flat Washer Ø10	4
89	BWMLS300089	Nylon Lock Nut M10	4
90	BWMLS300090	Jockey Wheel	1

## Customer Service:

303 Warrigal Road, Cheltenham, Victoria 3192, Australia

Telephone: 13000 454 585

Website: [www.BWMachinery.com.au](http://www.BWMachinery.com.au)

Email: [admin@bwmachinery.com.au](mailto:admin@bwmachinery.com.au)

Spare parts are available from our dealers and our official website