

341AC

Serial Number

38000001-38999999

Last updated date

29/Apr/2021

TABLE OF CONTENTS

CYLINDER, PISTON, CRANKSHAFT	1
ENGINE COVER.....	3
MAGNETO.....	5
AIR CLEANER, CARBURETOR.....	7
CARBURETOR.....	9
MUFFLER.....	11
RECOIL STARTER.....	13
HANDLE.....	15
CHAIN BRAKE.....	17
ACCESSORIES	19
GUIDE BAR, CHAIN.....	21

CYLINDER, PISTON, CRANKSHAFT

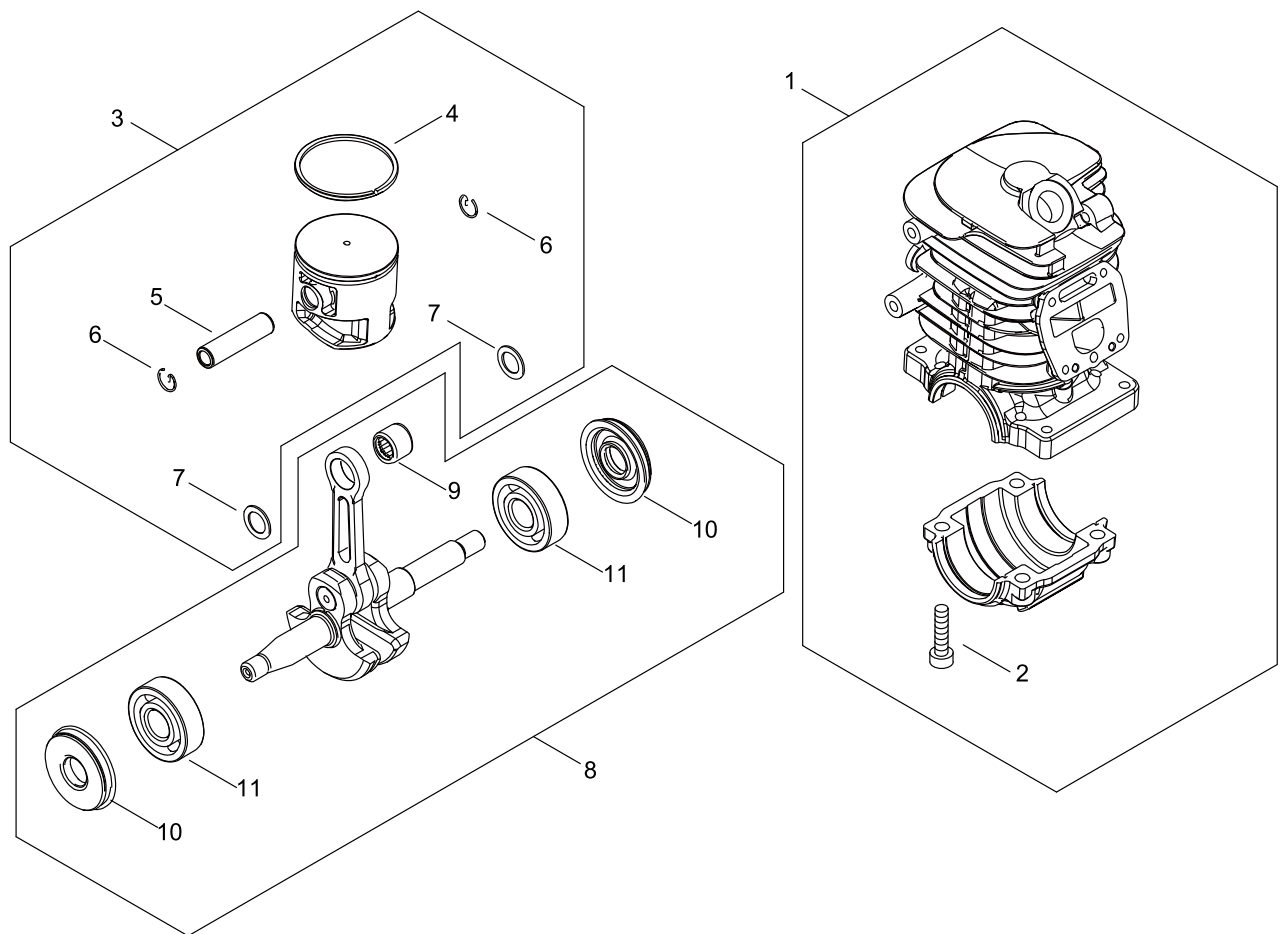

CYLINDER, PISTON, CRANKSHAFT

Key No.	LV (+)	Parts Number	Parts Description	Qty	Standard	Class
1		P100-009150	CRANKCASE KIT	1		
2	+	V805-000210	BOLT, TORX 5	4	TB-5*20 12.9	C
3		P100-009130	PISTON KIT	1		
4	+	A101-000160	RING, PISTON	1	40*B1.5*T1.8	B
5	+	V607-000000	PIN,ENG 9	1		D
6	+	100015-03931	CIRCLIP, PISTON PIN	2		C
7	+	V306-000520	WASHER,CIRCULAR 8	2	9.2*14*T0.8	C
8		P100-009140	CRANKSHAFT ASY	1		
9	++	V554-000030	BEARING,NEEDLE 9	1	HK0910MPX1V2	C
10	+	V505-000011	SEAL,OIL 12	2	12*32*5.5	C
11	+	94095-36201	BEARING, BALL	2	6201	

Class : Consumable class

A:Fast moving parts B:Semi-fast moving parts C:Slow moving parts D:Order only as needed

ENGINE COVER

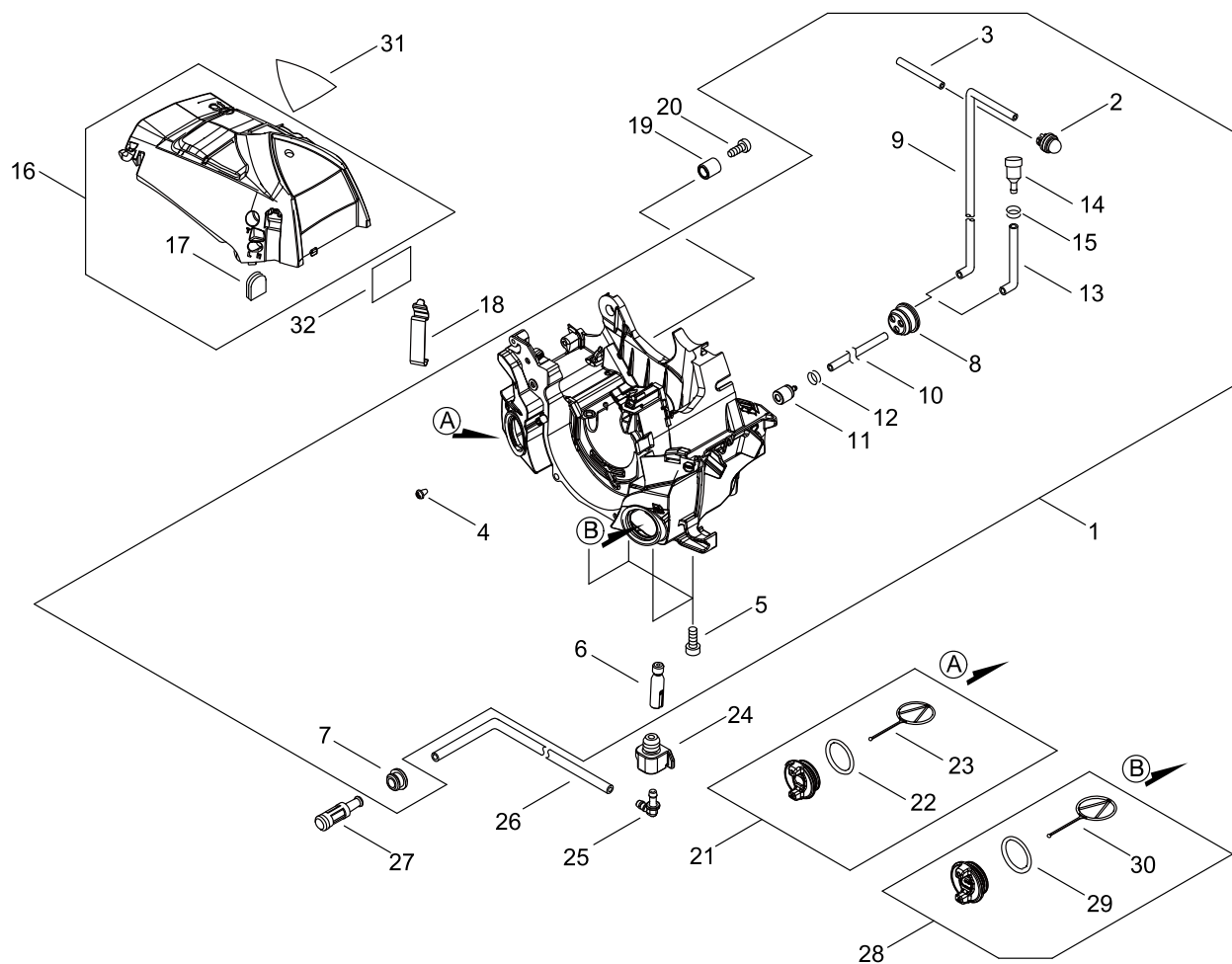

ENGINE COVER

Key No.	LV (+)	Parts Number	Parts Description	Qty	Standard	Class
1		P100-009800	COVER ENGINE ASY	1		
2	+	A035-000040	PUMP, FUEL	1	188-554-A	A
3	+	V471-001321	PIPE	1	2.4*5*90	C
4	+	91449-04006	SCREW, TAPPING	1	4*6	
5	+	V805-000210	BOLT, TORX 5	4	TB-5*20 12.9	C
6	+	C022-000190	AUTO-OILER ASSEMBLY	1		C
7	+	132115-01462	GROMMET	1		C
8	+	132115-46730	GROMMET, FUEL	1		C
9	+	V471-001241	PIPE	1	2.4*5*140	C
10	+	V471-001231	PIPE	1	3*5*210	C
11	+	A369-000470	STRAINER, FUEL	1		A
12	+	V490-001240	CLIP	1		C
13	+	V471-001201	PIPE	1	3*5*70	C
14	+	A356-000031	VALVE,CHECK	1		B
15	+	V490-001240	CLIP	1		C
16		P100-009810	CYLINDER COVER ASY	1		
17	+	130338-32430	PLUG, COVER	1		B
18		V490-001730	CLIP	2		C
19		C310-000110	CATCHER, CHAIN	1		B
20		V203-002260	BOLT,5	1		C
21		P100-009040	CAP ASY	1		
22	+	900720-20029	O-RING	1	P-29	
23	+	131051-19830	LINK	1	60L	B
24		V138-000030	GROMMET,OIL	1		C
25		V186-000530	JOINT,PIPE	1		C
26		437210-30831	PIPE	1	3*6*210	C
27		P100-001900	STRAINER, OIL	1		
28		P100-009070	CAP ASY	1		
29	+	V581-000600	RING,O	1	P29	A
30	+	131051-19830	LINK	1	60L	B
31		X562-001650	LABEL,SHINDAIWA	1	SHIDAIWA+341AC	D
32		X505-011340	LABEL,CAUTION	1	25.5*55	D

Class : Consumable class

A:Fast moving parts B:Semi-fast moving parts C:Slow moving parts D:Order only as needed

MAGNETO

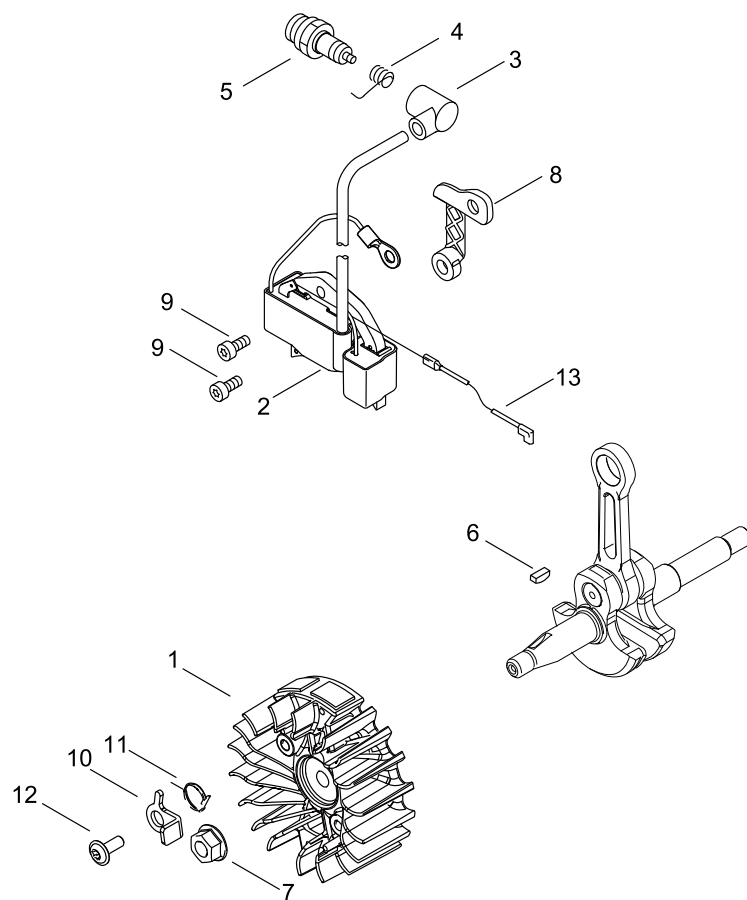

MAGNETO

Key No.	LV (+)	Parts Number	Parts Description	Qty	Standard	Class
1		A409-000350	ROTOR, MAGNETO	1	WALBRO FW57	C
2		A411-001900	COIL, IGNITION	1	WALBRO MBU-108	C
3		A427-000020	CAP, SPARK PLUG	1		C
4		A426-000020	TERMINAL, SPARKPLUG	1		C
5		A425-000000	SPARKPLUG	1	BPMR8Y	A
6		100142-12330	KEY, WOODRUFF	1		C
7		900515-00008	NUT, FLANGE	1	8	
8		V376-002500	SPACER	1		C
9		V805-000210	BOLT, TORX 5	2	TB-5*20 12.9	C
10		A514-000020	PAWL	2		C
11		177234-35430	SPRING, RETURN	2		B
12		V203-002250	BOLT, 5	2		C
13		V485-003430	LEAD	1	AV0.5F-L:185	C

Class : Consumable class

A:Fast moving parts B:Semi-fast moving parts C:Slow moving parts D:Order only as needed

AIR CLEANER, CARBURETOR

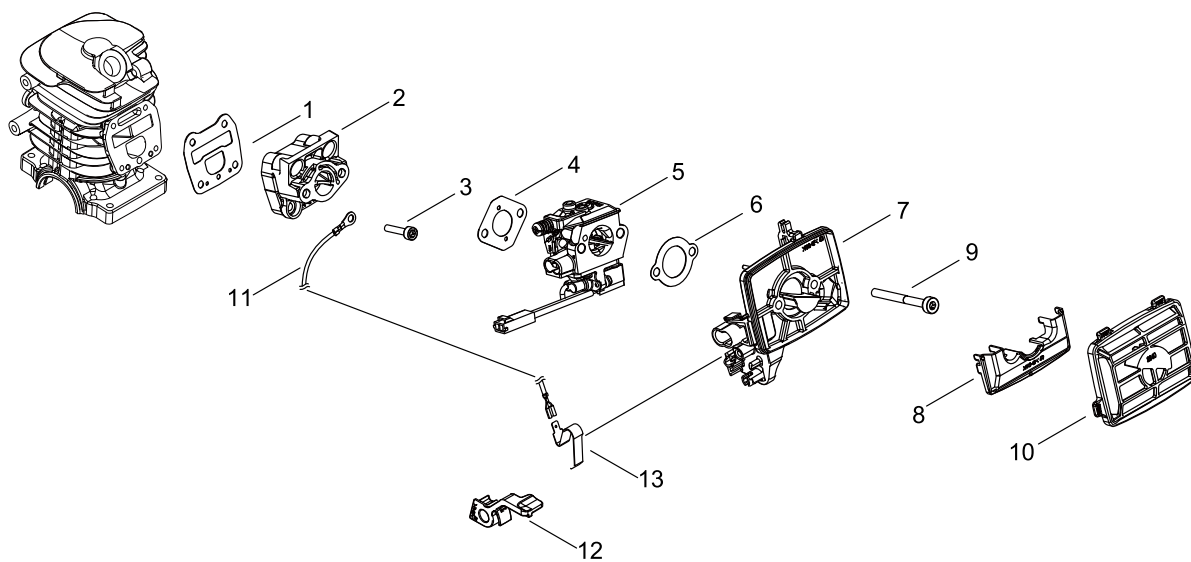

AIR CLEANER, CARBURETOR

Key No.	LV (+)	Parts Number	Parts Description	Qty	Standard	Class
1		V103-002160	GASKET,INTAKE	1		A
2		A200-001260	INSULATOR, INTAKE	1		C
3		V804-000070	BOLT, TORX 4	4	TB-4*20 12.9	C
4		V103-002170	GASKET,INTAKE	1		A
5		A021-005190	CARBURETOR,DIAPHRAGM	1	WT-1237	B
6		V103-000500	GASKET,INTAKE	1	ASK NO.4600	A
7		A238-000090	HOLDER, ELEMENT	1		C
8		A161-000420	DUCT, AIR	1		C
9		V805-000080	BOLT, TORX 5	2	TB-5*50 10.9	C
10		A226-002350	ELEMENT, AIR FILTER	1	NON-WOVEN	A
11		V485-003420	LEAD	1		C
12		A444-000150	KNOB, SWITCH	1		C
13		A443-000190	PLATE, CONTACT	1		C

Class : Consumable class

A:Fast moving parts B:Semi-fast moving parts C:Slow moving parts D:Order only as needed

CARBURETOR

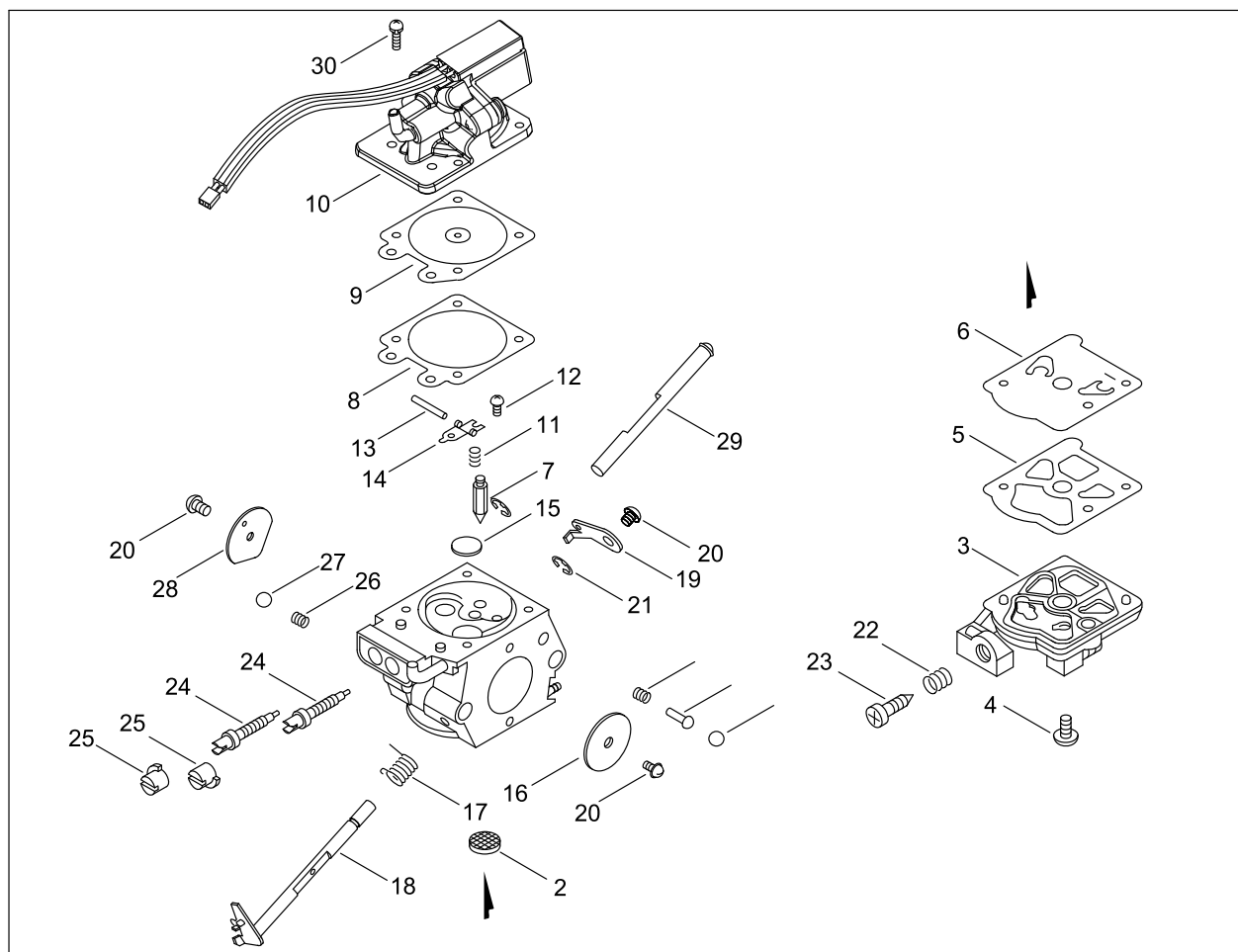

CARBURETOR

Key No.	LV (+)	Parts Number	Parts Description	Qty	Standard	Class
1		A021-005190	CARBURETOR,DIAPHRAGM	1	WT-1237	B
2	+	123126-10631	SCREEN, INLET	1		
3	+	123124-09520	COVER, FUEL PUMP	1		
4	+	123110-03930	SCREW, PUMP COVER	1		
5	+	123125-15030	GASKET, FUEL PUMP	1		
6	+	123112-15030	DIAPHRAGM, FUEL PUMP	1		
7	+	123137-19830	VALVE, INLET NEEDLE	1		
8	+	P003-006020	GASKET, M. DIAPHRAGM	1		
9	+	P003-001850	DIAPHRAGM, METERING	1		
10	+	P003-006460	COVER ASY, METERING	1		
11	+	123122-03660	SPRING, METER. LEVER	1		
12	+	123139-03930	SCREW, M. LEVER PIN	1		
13	+	123138-03930	PIN, METERING LEVER	1		
14	+	123123-03930	LEVER, METERING	1		
15	+	123146-10631	PLUG, WELCH	1		
16	+	P003-000310	VALVE THROTTLE	1		
17	+	123113-37530	SPRING, THROTTLE RTN	1		B
18	+	P003-000480	SHAFT,THROTTLE	1		
19	+	P003-006470	LEVER, THROTTLE	1		
20	+	123114-38830	SCREW	3		
21	+	123127-15030	RING	1		
22	+	123133-04260	SPRING, IDLE ADJUST	1		
23	+	123134-04260	SCREW, IDLE ADJUST	1		
24	+	P003-004820	NEEDLE	2		D
25	+	P003-000010	LIMITER CAP	2		
26	+	123135-10630	SPRING, CHOKE FRICT.	1		
27	+	123136-10630	BALL, CHOKE FRICTION	1		
28	+	P003-003350	CHOKE VALVE	1		
29	+	P003-006050	SHAFT-CHOKE	1		
30	+	P003-006060	SCREW	4		

Class : Consumable class

A:Fast moving parts B:Semi-fast moving parts C:Slow moving parts D:Order only as needed

MUFFLER

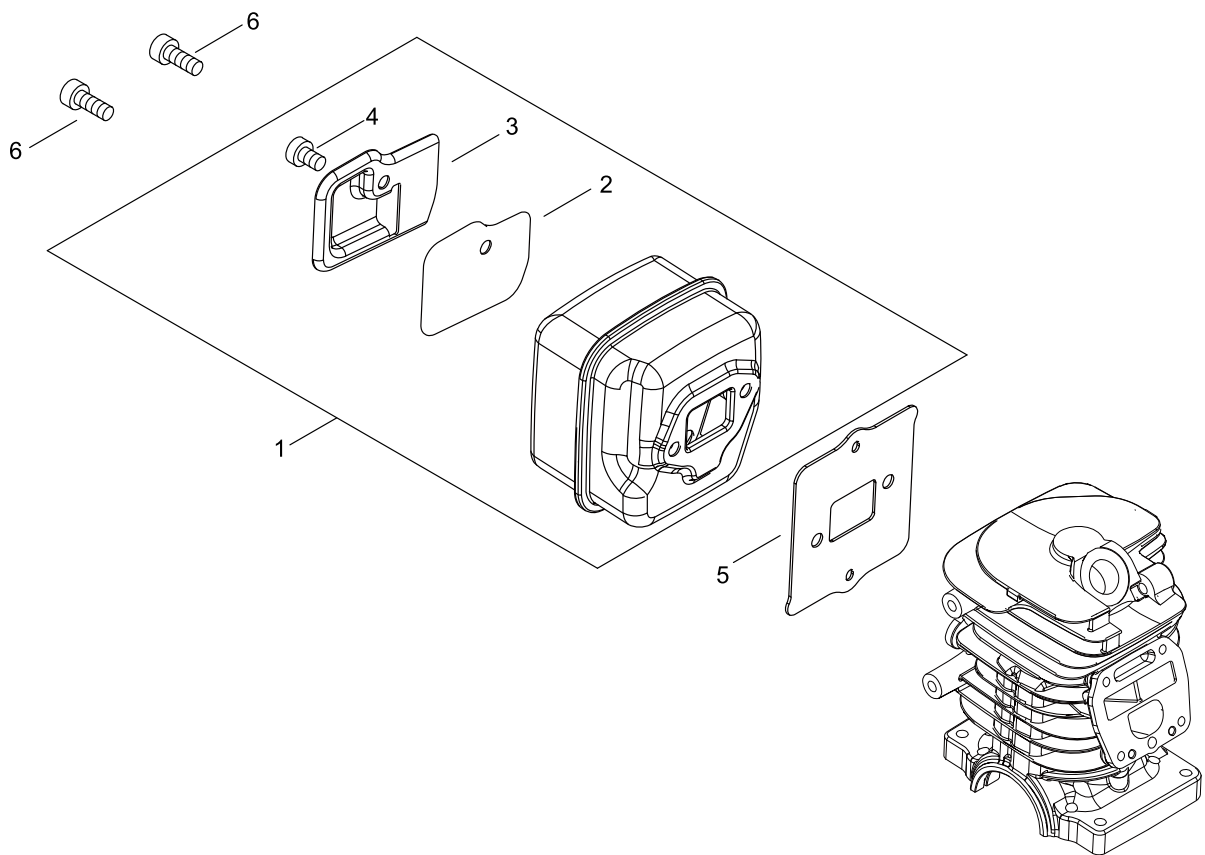

MUFFLER

Key No.	LV (+)	Parts Number	Parts Description	Qty	Standard	Class
1		P100-009160	MUFFLER ASY	1		
2	+	A310-000570	SCREEN, ARRESTOR	1	0.34X30	B
3	+	A313-002110	GUIDE, EXHAUST	1	T0.8 ID#2720	C
4	+	V805-000120	BOLT, TORX 5	1	TB-5*8 10.9	C
5		V104-002510	GASKET,EXHAUST	1		A
6		V805-000250	BOLT, TORX 5	2	TB-5*16 12.9	C

Class : Consumable class

A:Fast moving parts B:Semi-fast moving parts C:Slow moving parts D:Order only as needed

RECOIL STARTER

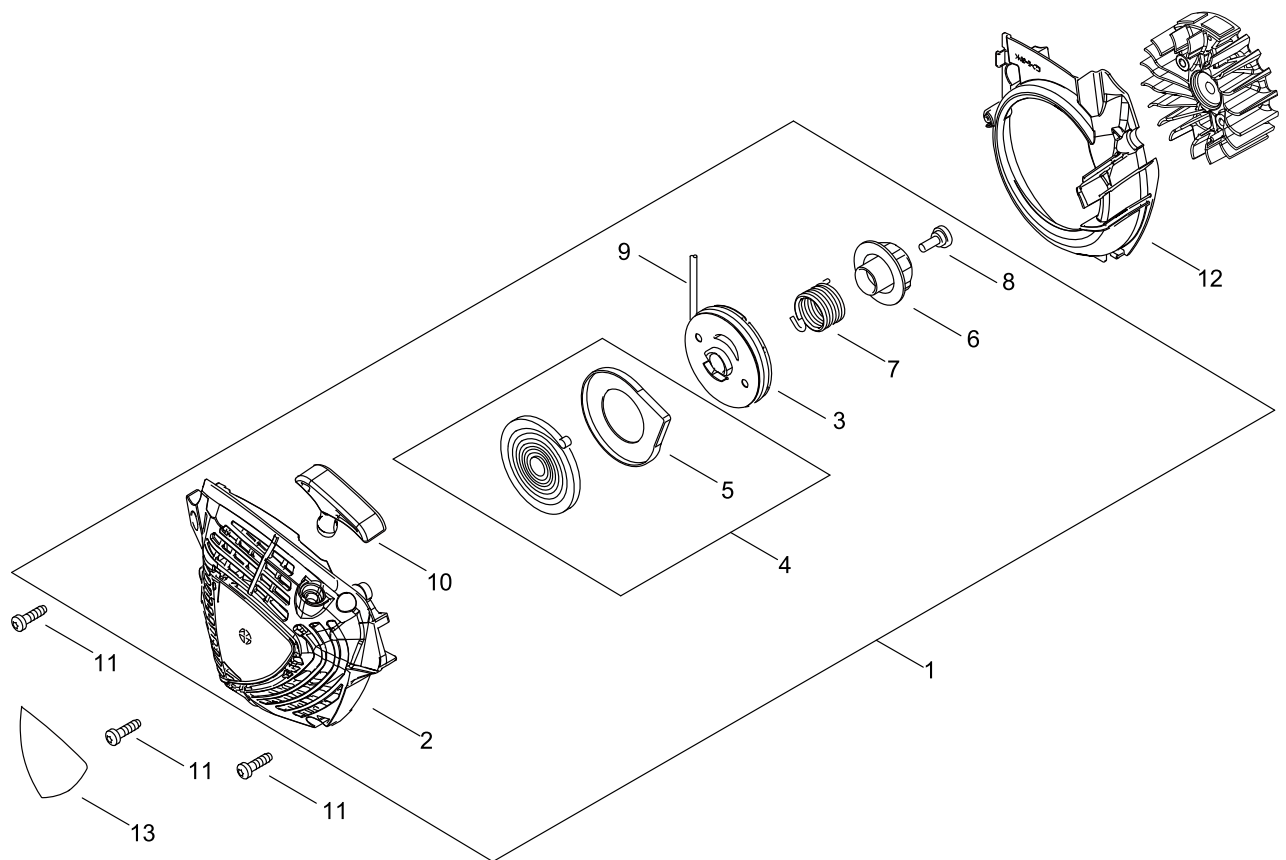

RECOIL STARTER

Key No.	LV (+)	Parts Number	Parts Description	Qty	Standard	Class
1		A051-003490	STARTER,RECOIL ASY	1		B
2	+	P022-055660	CASE,STARTER	1		
3	+	P022-055670	DRUM, STARTER	1		
4	+	P022-001330	SPRING KIT, REWIND	1		
5	++	P022-033280	SPRING CASE	1		
6	+	A507-000110	CATCHER,PAWL	1		C
7	+	V452-001320	SPRING,TORSION	1		B
8	+	177236-61830	SCREW	1		
9	+	P022-008440	ROPE, STARTER	1	3.5*900	
10	+	P022-005891	GRIP, STARTER	1		
11		V805-000010	BOLT, TORX 5	3	TT-5*20 DG 10.9	C
12		A172-003620	COVER,FAN	1		C
13		X503-015580	LABEL,MODEL	1	341AC	D

Class : Consumable class

A:Fast moving parts B:Semi-fast moving parts C:Slow moving parts D:Order only as needed

HANDLE

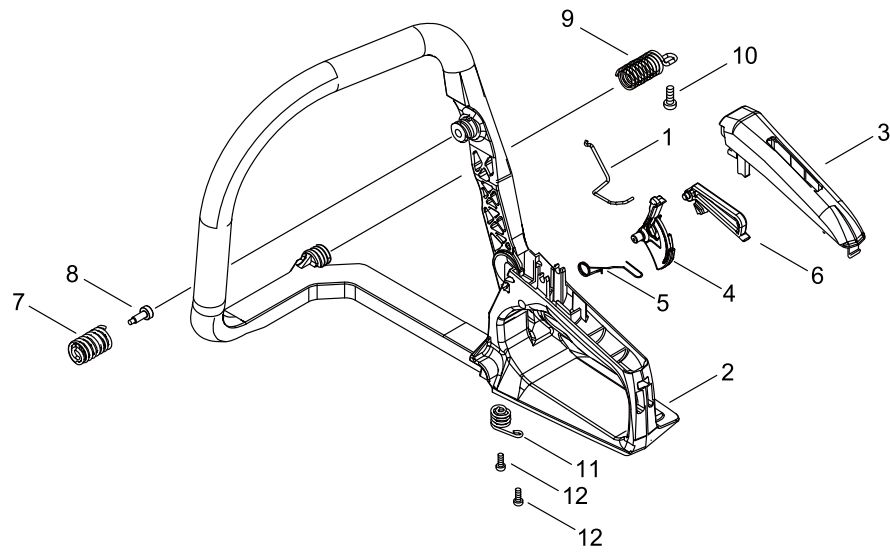

HANDLE

Key No.	LV (+)	Parts Number	Parts Description	Qty	Standard	Class
1		C454-000610	ROD, THROTTLE	1		C
2		C410-001500	HANDLE, REAR	1		C
3		C411-000280	LID,HANDLE	1		C
4		C450-001090	TRIGGER,THROTTLE	1		C
5		V452-000850	SPRING,TORSION	1		B
6		C460-000650	LOCKOUT,THROTTLE	1		C
7		V450-002370	SPRING,COMPRESSION	1		B
8		V805-000390	BOLT, TORX 5	1	TB-5*16 10.9	C
9		V450-002380	SPRING,COMPRESSION	1		B
10		V805-000000	BOLT, TORX 5	1	TT-5*16 DG 10.9	C
11		V450-002390	SPRING,COMPRESSION	1		B
12		V805-000000	BOLT, TORX 5	2	TT-5*16 DG 10.9	C

Class : Consumable class

A:Fast moving parts B:Semi-fast moving parts C:Slow moving parts D:Order only as needed

CHAIN BRAKE

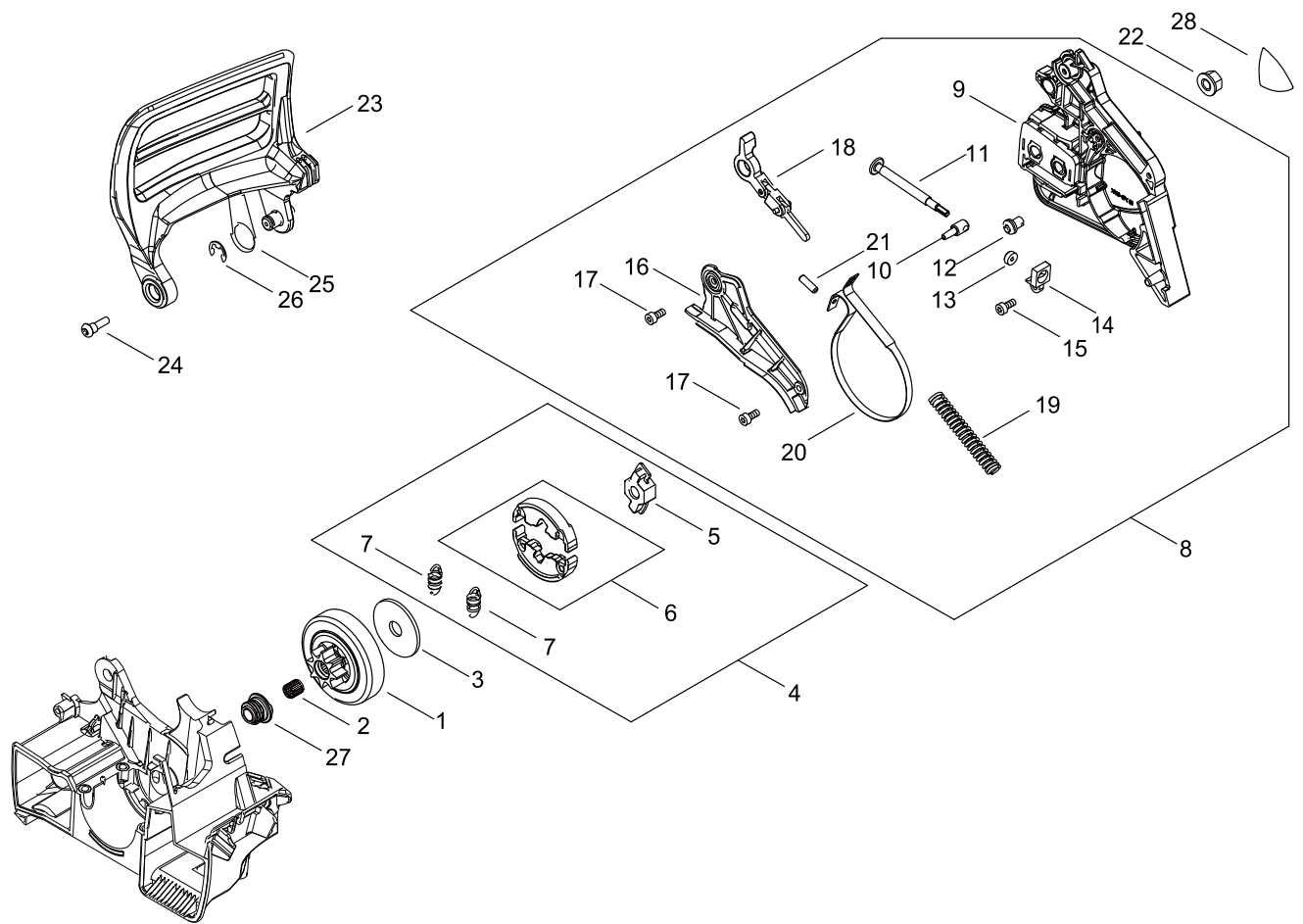

CHAIN BRAKE

Key No.	LV (+)	Parts Number	Parts Description	Qty	Standard	Class
1		A556-001880	DRUM, CLUTCH	1	3/8	B
2		V555-000170	BEARING,NEEDLE 10	1	8E-KV10*13*12.8	B
3		A551-000210	PLATE, CLUTCH	1		C
4		A056-000870	CLUTCH ASY	1		B
5	+	A552-000500	HUB, CLUTCH	1		B
6	+	P100-009170	CLUTCH SHOE SET	1		
7	+	A566-000350	SPRING, CLUTCH	2		B
8		P100-009580	GUARD, SPROCKET ASY	1		
9	+	C300-001190	GUARD, SPROCKET	1		C
10	+	C309-000030	TENSIONER,CHAIN	1		C
11	+	V203-000110	BOLT,5	1		C
12	+	V651-000001	GEAR,BEVEL	1		D
13	+	V651-000011	GEAR,BEVEL	1		D
14	+	V355-000140	COLLAR,8	1		C
15	+	V804-000000	BOLT, TORX 4	1	TT-4*12 DG 10.9	C
16	+	C345-000720	COVER,BRAKE	1		C
17	+	V804-000000	BOLT, TORX 4	2	TT-4*12 DG 10.9	C
18	+	C334-000100	CONNECTOR, BRAKE	1		C
19	+	V450-000070	SPRING,COMPRESSION	1		B
20	+	C328-000030	BAND,BRAKE	1		C
21	+	93050-30098	ROLLER	1	3*9.8	
22		V265-000200	NUT	2		C
23		C320-000590	LEVER, BRAKE	1		C
24		V203-002270	BOLT,5	1		C
25		V452-000250	SPRING,TORSION	1		B
26		900700-00008	RETAINING RING, EXTERNAL-E	1	CE-8	
27		V652-000280	GEAR,WORM	1		B
28		X560-000120	LABEL,SHINDAIWA	1		D

Class : Consumable class

A:Fast moving parts B:Semi-fast moving parts C:Slow moving parts D:Order only as needed

ACCESSORIES

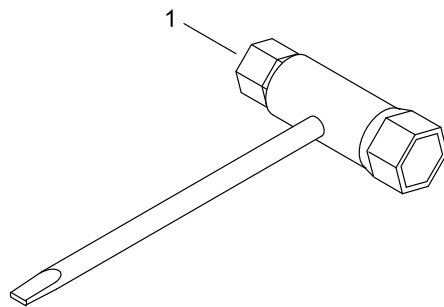



ACCESSORIES

Key No.	LV (+)	Parts Number	Parts Description	Qty	Standard	Class
1		X602-000080	TOOL,WRENCH	1	13*19 L180	D

Class : Consumable class

A:Fast moving parts B:Semi-fast moving parts C:Slow moving parts D:Order only as needed

GUIDE BAR, CHAIN

Pitch ピッチ (inch) (mm)	Gauge ゲージ (inch) (mm)	Length 長さ (cm)	Guide Bar ガイドバー		Saw Chain ソーチェーン		Hard Nose ハード ノーズ 	Sprocket Nose スプロケット ノーズ 
			Key №	Type 形式	Key №	Type 形式		
3/8 9.53	0.050 1.27	30	A1	C30S91-47ML- SC	A2	91PX-47E		●
3/8 9.53	0.050 1.27	30	B1	C30S91-47ML- SC	B2	91VXL-47E		●
3/8 9.53	0.043 1.09	35	C1	C35S90-52SA- ST	C2	90PX-52E		●
3/8 9.53	0.050 1.27	35	D1	C35S91-53ML- SC	D2	91PX-53E		●
3/8 9.53	0.050 1.27	35	E1	C35S91-53ML- SC	E2	91VXL-53E		●
3/8 9.53	0.050 1.27	40	F1	C40S91-58AL- ST	F2	91PX-58E		●
3/8 9.53	0.050 1.27	40	G1	C40S91-58AL- ST	G2	91VXL-58E		●

GUIDE BAR, CHAIN

Key No.	LV (+)	Parts Number	Parts Description	Qty	Standard	Class
A1		X122-000351	BAR,GUIDE 30	1	C30S91-47ML- SC	A
A2		X222-000140	CHAIN,SAW	1	91PX-47E	A
B1		X122-000351	BAR,GUIDE 30	1	C30S91-47ML- SC	A
B2		X222-000130	CHAIN,SAW	1	91VXL-47E	A
C1		X123-000690	BAR,GUIDE 35	1	C35S90-52SA- ST	A
C2		X223-000150	CHAIN,SAW	1	90PX-52E	A
D1		X123-000561	BAR,GUIDE 35	1	C35S91-53ML- SC	A
D2		X223-000130	CHAIN,SAW	1	91PX-53E	A
E1		X123-000561	BAR,GUIDE 35	1	C35S91-53ML- SC	A
E2		X223-000080	CHAIN,SAW	1	91VXL-53E	A
F1		X124-000730	BAR,GUIDE 40	1	C40S91-58AL- ST	A
F2		X224-000070	CHAIN,SAW	1	91PX-58E	A
G1		X124-000730	BAR,GUIDE 40	1	C40S91-58AL- ST	A
G2		X224-000030	CHAIN,SAW	1	91VXL-58E	A

Class : Consumable class

A:Fast moving parts B:Semi-fast moving parts C:Slow moving parts D:Order only as needed

NUMERICAL PARTS INDEX

Part No	Part description	Page	Part No	Part description	Page	Part No	Part description	Page
100015-03931	CIRCLIP, PISTON PIN	2	A238-000090	HOLDER, ELEMENT	8	P022-033280	SPRING CASE	14
100142-12330	KEY, WOODRUFF	6	A310-000570	SCREEN, ARRESTOR	12	P022-055660	CASE,STARTER	14
123110-03930	SCREW, PUMP COVER	10	A313-002110	GUIDE, EXHAUST	12	P022-055670	DRUM, STARTER	14
123112-15030	DIAPHRAGM, FUEL PUMP	10	A356-000031	VALVE,CHECK	4	P100-001900	STRAINER, OIL	4
123113-37530	SPRING, THROTTLE RTN	10	A369-000470	STRAINER, FUEL	4	P100-009040	CAP ASY	4
123114-38830	SCREW	10	A409-000350	ROTOR, MAGNETO	6	P100-009070	CAP ASY	4
123122-03660	SPRING, METER. LEVER	10	A411-001900	COIL, IGNITION	6	P100-009130	PISTON KIT	2
123123-03930	LEVER, METERING	10	A425-000000	SPARKPLUG	6	P100-009140	CRANKSHAFT ASY	2
123124-09520	COVER, FUEL PUMP	10	A426-000020	TERMINAL,SPARKPLUG	6	P100-009150	CRANKCASE KIT	2
123125-15030	GASKET, FUEL PUMP	10	A427-000020	CAP,SPARK PLUG	6	P100-009160	MUFFLER ASY	12
123126-10631	SCREEN, INLET	10	A443-000190	PLATE, CONTACT	8	P100-009170	CLUTCH SHOE SET	18
123127-15030	RING	10	A444-000150	KNOB, SWITCH	8	P100-009580	GUARD, SPROCKET ASY	18
123133-04260	SPRING, IDLE ADJUST	10	A507-000110	CATCHER,PAWL	14	P100-009800	COVER ENGINE ASY	4
123134-04260	SCREW, IDLE ADJUST	10	A514-000020	PAWL	6	P100-009810	CYLINDER COVER ASY	4
123135-10630	SPRING, CHOKE FRICT.	10	A551-000210	PLATE, CLUTCH	18	V103-000500	GASKET,INTAKE	8
123136-10630	BALL, CHOKE FRICTION	10	A552-000500	HUB, CLUTCH	18	V103-002160	GASKET,INTAKE	8
123137-19830	VALVE, INLET NEEDLE	10	A556-001880	DRUM, CLUTCH	18	V103-002170	GASKET,INTAKE	8
123138-03930	PIN, METERING LEVER	10	A566-000350	SPRING, CLUTCH	18	V104-002510	GASKET,EXHAUST	12
123139-03930	SCREW, M. LEVER PIN	10	C022-000190	AUTO-OILER ASSEMBLY	4	V138-000030	GROMMET,OIL	4
123146-10631	PLUG, WELCH	10	C300-001190	GUARD, SPROCKET	18	V186-000530	JOINT,PIPE	4
130338-32430	PLUG, COVER	4	C309-000030	TENSIONER,CHAIN	18	V203-000110	BOLT,5	18
131051-19830	LINK	4	C310-000110	CATCHER, CHAIN	4	V203-002250	BOLT,5	6
132115-01462	GROMMET	4	C320-000590	LEVER, BRAKE	18	V203-002260	BOLT,5	4
132115-46730	GROMMET, FUEL	4	C328-000030	BAND,BRAKE	18	V203-002270	BOLT,5	18
177234-35430	SPRING, RETURN	6	C334-000100	CONNECTOR, BRAKE	18	V265-000200	NUT	18
177236-61830	SCREW	14	C345-000720	COVER,BRAKE	18	V306-000520	WASHER,CIRCULAR 8	2
437210-30831	PIPE	4	C410-001500	HANDLE, REAR	16	V355-000140	COLLAR,8	18
900515-00008	NUT, FLANGE	6	C411-000280	LID,HANDLE	16	V376-002500	SPACER	6
900700-00008	RETAINING RING, EXTERNAL-E	18	C450-001090	TRIGGER,THROTTLE	16	V450-000070	SPRING,COMPRESSION	18
900720-20029	O-RING	4	C454-000610	ROD, THROTTLE	16	V450-002370	SPRING,COMPRESSION	16
91449-04006	SCREW, TAPPING	4	C460-000650	LOCKOUT,THROTTLE	16	V450-002380	SPRING,COMPRESSION	16
93050-30098	ROLLER	18	P003-000010	LIMITER CAP	10	V450-002390	SPRING,COMPRESSION	16
94095-36201	BEARING, BALL	2	P003-000310	VALVE THROTTLE	10	V452-000250	SPRING,TORSION	18
A021-005190	CARBURETOR, DIAPHRAGM	8	P003-000480	SHAFT,THROTTLE	10	V452-000850	SPRING,TORSION	16
A021-005190	CARBURETOR, DIAPHRAGM	10	P003-001850	DIAPHRAGM, METERING	10	V452-001320	SPRING,TORSION	14
A035-000040	PUMP, FUEL	4	P003-003350	CHOKE VALVE	10	V471-001201	PIPE	4
A051-003490	STARTER,RECOIL ASY	14	P003-004820	NEEDLE	10	V471-001231	PIPE	4
A056-000870	CLUTCH ASY	18	P003-006020	GASKET, M. DIAPHRAGM	10	V471-001241	PIPE	4
A101-000160	RING, PISTON	2	P003-006050	SHAFT-CHOKE	10	V471-001321	PIPE	4
A161-000420	DUCT, AIR	8	P003-006060	SCREW	10	V485-003420	LEAD	8
A172-003620	COVER,FAN	14	P003-006460	COVER ASY, METERING	10	V485-003430	LEAD	6
A200-001260	INSULATOR, INTAKE	8	P003-006470	LEVER, THROTTLE	10	V490-001240	CLIP	4
A226-002350	ELEMENT, AIR FILTER	8	P022-001330	SPRING KIT, REWIND	14	V490-001730	CLIP	4
			P022-005891	GRIP, STARTER	14	V505-000011	SEAL,OIL 12	2
			P022-008440	ROPE, STARTER	14	V554-000030	BEARING,NEEDLE 9	2

NUMERICAL PARTS INDEX

Part No	Part description	Page
V555-000170	BEARING,NEEDLE 10	18
V581-000600	RING,O	4
V607-000000	PIN,ENG 9	2
V651-000001	GEAR,BEVEL	18
V651-000011	GEAR,BEVEL	18
V652-000280	GEAR,WORM	18
V804-000000	BOLT, TORX 4	18
V804-000070	BOLT, TORX 4	8
V805-000000	BOLT, TORX 5	16
V805-000010	BOLT, TORX 5	14
V805-000080	BOLT, TORX 5	8
V805-000120	BOLT, TORX 5	12
V805-000210	BOLT, TORX 5	2
V805-000210	BOLT, TORX 5	4
V805-000210	BOLT, TORX 5	6
V805-000250	BOLT, TORX 5	12
V805-000390	BOLT, TORX 5	16
X122-000351	BAR,GUIDE 30	22
X123-000561	BAR,GUIDE 35	22
X123-000690	BAR,GUIDE 35	22
X124-000730	BAR,GUIDE 40	22
X222-000130	CHAIN,SAW	22
X222-000140	CHAIN,SAW	22
X223-000080	CHAIN,SAW	22
X223-000130	CHAIN,SAW	22
X223-000150	CHAIN,SAW	22
X224-000030	CHAIN,SAW	22
X224-000070	CHAIN,SAW	22
X503-015580	LABEL,MODEL	14
X505-011340	LABEL,CAUTION	4
X560-000120	LABEL,SHINDAIWA	18
X562-001650	LABEL,SHINDAIWA	4
X602-000080	TOOL,WRENCH	20