

MULTI INTERNATIONAL GOLD MEDALS & AWARD WINNING PRODUCTS PETROL & BATTERY - LAWN EDGERS - TILLERS - AIRLIFT® BLOWERS, BATTERY LINE TRIMMER - DRILLMASTER® ENGINE DRILLS

Operator Manual always to be available for reference or instructing new operators. Read carefully before use.

AS WITH ANY POWER TOOL IMPROPER USE CAN CAUSE SERIOUS INJURY. **Make sure all instructions are carefully understood before starting or operating this equipment.**

Operator is responsible for accidents or hazards occurring to others or their property. It is important that you read and understand the maintenance and safety precautions before using the unit. Contact your Atom dealer or the Atom distributor in your area or visit the Atom website, if you do not understand or cannot carry out any of the operating instructions in this Manual.

Atom's philosophy is to continually improve all of its products. As a result, engineering changes and improvements are made from time to time. Appearances may differ between models. This manual covers information required to operate, maintain and service a range of Atom products.

SAFETY WARNING The purpose of Safety Warnings and Notes in this Manual is to attract your attention to possible dangers and deserve your careful attention and understanding. The Safety Warnings in this Manual and on the product do not, by themselves, eliminate any danger. **The instructions or warnings they give are not substitutes for proper accident prevention measures.**

WARNING Failure to obey a safety warning can result in serious injury to yourself, others and property.

NOTE Advises you of information or instructions vital to the operation or maintenance of the equipment.

SAFETY WARNING LABELS



Keep hands clear of moving parts



WARNING: ALWAYS REPLACE FUEL CAP SECURELY. METAL PARTS OF ENGINE HOT DURING & AFTER USE. DO NOT TOUCH.

AFTER FIRST 30 MINUTES USE, CLEAN & OIL AIR FILTER & THEREAFTER EVERY 5 HOURS.



Do not touch hot engine parts

CONTENTS

LAWN EDGERS PETROL & BATTERY



Safety Precautions	1-2
Assembling	4
Parts & Controls	6
Fuel & Oils (petrol models)	9
Starting & Stopping (petrol models)	10
OPERATING	11
Blades replacement & Maintenance	16
Air Cleaner (petrol models)	18
Maintenance	18-19
Troubleshooting	20
Charging Battery	12
Battery power information	20

TILLERS PETROL & BATTERY



Safety Precautions	1-2
Assembling	4
Parts & Controls	7
Fuel & Oils (petrol models)	9
Starting & Stopping (petrol models)	10
OPERATING	13
Maintenance	16
Gear Lubrication	16
Air Cleaner (petrol models)	18
Maintenance	18-19
Troubleshooting	20
Charging Battery	12
Battery power information	20

AIRLIFT BLOWERS PETROL & BATTERY



Safety Precautions	1-2
Assembling	5
Parts & Controls	8
Fuels & Oils (petrol models)	9
Starting & Stopping (petrol models)	10
OPERATING	14
Maintenance	17
Air Cleaner (petrol models)	18
Maintenance	18-19
Troubleshooting	20-21
Charging Battery	12
Battery power information	20

DRILLMASTER ENGINE DRILLS



Safety Precautions	1-2
Assembling	5
Parts & Controls	8
Fuels & Oils	9
Starting & Stopping	10
OPERATING	14
Gear Lubrication	17
Maintenance	17
Air Cleaner Maintenance	18
Engine Maintenance	18-19
Troubleshooting	20
Sharpening Augers	21

BATTERY STRING TRIMMER



Safety Precautions	1-2
Assembling (incl attachments)	8

Parts & Controls	8
OPERATING	8
Nylon Chord Rewinding	8
Troubleshooting	20
Charging Battery	12
Battery power information	20

SAFETY PRECAUTIONS ALL ATOM EQUIPMENT

- WARNING**
1. Keep hands, feet away from all moving parts.
 2. Avoid dangerous situations. Do not use in the presence of flammable liquids or gasses to avoid creating a fire or explosion.
 3. Do NOT use or have machine in rain. Do NOT use water hose to clean machine as internal water damage can occur.

4. Store unit in a secure dry place indoors. Do not store unit outside or back of ute or truck exposed to rain.
5. Before doing any maintenance or repair work, or cleaning the unit or blades, adjusting wheel depth, engine must be switched off and, if battery powered, remove battery.
6. Do not attempt to use unit if there is any damage. Do not use until damage is repaired by an authorised service centre.

SAFETY PRECAUTIONS

! WARNING As with any power tool, any rotating parts eg blades, fans, augers, etc, are dangerous and contact by any part of your body including hands, feet or clothing, will cause serious injury. It is important that you read, fully understand, and observe the following safety precautions and warnings. Re-read this operator's manual and the safety instructions periodically. Read and understand all labels attached to the products.

! WARNING Do not lend, rent or sell this machine without the operator's manual. Be sure that anyone using this unit understands the information contained in this manual before use.

! WARNING As with any power tool, some special safety precautions must be observed to reduce the risk of personal injury. Careless or improper use may cause serious or even fatal injury.

This appliance is not intended for use by persons (including children) with reduced, physical, sensory or mental capabilities or lack of experience or knowledge unless they have been given supervision or instruction by a person responsible for their safety.

Children should be supervised to ensure that they do not play with the appliance.

FIG 3



THE OPERATOR

PHYSICAL CONDITION

Operator must be in good physical condition and mental health, and not under the influence of any substance (drugs, alcohol, etc.) which might impair vision, dexterity or judgement (Fig 3).

Do not operate when fatigued. Be alert – if you get tired while operating the machine, take a break. Tiredness may result in loss of control. Working with any power tool can be strenuous. If you have any condition that might be aggravated by strenuous work, check with your doctor before operating the machine.

! WARNING The unit must not be operated by minors. Bystanders, especially children and animals should not be allowed in this area where a machine is in use and be at least 15 metres (50 feet) away (Fig 4). If approached switch off motor immediately. **When not in use store out of reach of children.**



FIG 4

PROPER CLOTHING

Clothing must be sturdy and snug-fitting, but allow complete freedom of movement (See Fig 5). Avoid loose-fitting jackets, flared or cuffed pants, or anything that could trip the operator. Wear overalls or long pants to protect your legs. DO NOT wear shorts. Use of gloves when working is recommended.

Good footing is most important. Wear sturdy shoes with nonslip soles. DO NOT operate with bare feet. In hot or sunny conditions, always wear a hat and long sleeve shirt for protection against skin cancers. Use of a good brand of sunscreen cream is also recommended on exposed skin surfaces. Always wear ear muffs or ear plugs.



FIG 5

! WARNING Proper eye protection is a must. The covers may not protect the operator from all moving foreign objects, even though the discharge is directed away from the operator, as ricochets and bouncebacks may occur during operations. Never operate unless wearing goggles or properly fitting safety glasses with adequate front and side protection which comply with ANSI Z 87.1.

! WARNING Replace immediately any worn or broken debris deflector shield, blade, cover, air inlet guard or any other damaged part. Check from time to time that all screws are tight.

SAFE WORKING INSTRUCTIONS AND IMPORTANT ADJUSTMENTS

Never operate your machine if it is damaged, improperly adjusted or not completely and securely assembled.

Use only original Atom replacement parts for maintenance and repair. Use of parts manufactured by others will void warranty and/or may cause serious or fatal injury. Electric repairs are only to be carried out by an authorised repairer.

! WARNING When using Edgers & Tillers Always stop the motor, make sure that the blades have stopped, before adjusting blade height.

Follow the maintenance instructions in the appropriate section of this manual. Any motor repairs should be carried out by a person with suitable servicing experience. With battery powered machines, always remove battery before carrying out maintenance or adjustments.

SAFE STARTING AND WORKING CONDITIONS

Always inspect that the unit is in good working order before use. When working, always wrap your fingers tightly around the handle grip. Keep your hands in this position to have your machine under control at all times. NEVER attempt to operate the Atom Edger, Tiller or Drill with one hand, as a loss of control may result in serious or fatal injury. Make sure the handle grips are in good condition and free of moisture, oil or grease. Use both hands, one on each handle, to operate. Do not overreach. Keep proper footing and balance at all times.

! WARNING The Atom unit is a one-person machine. To reduce risk of eye or other injury from thrown objects, ensure that bystanders are at least 15 metres (50 feet) away during use. Replace immediately any worn or broken parts. If approached, release throttle trigger to immediately de-accelerate the engine to idle.

! WARNING Prolonged use of any hand-held powered machine exposing the operator to vibrations may produce whitefinger disease (Raynaud's) phenomenon or carpal tunnel syndrome. These conditions reduce the hand's ability to feel and regulate temperature, produce numbness and burning sensations, and may cause nerve and circulation damage and tissue necrosis. Extensive hours of continuous use is not recommended.

SAFE FUELING INSTRUCTIONS

! WARNING Petrol is an extremely flammable and explosive fuel. Use extreme caution when handling petrol. Do not smoke or bring any fire or flame near the fuel.



Refuel outdoors only. **Always switch off the engine and allow it to cool before refueling. Relieve fuel tank pressure by loosening fuel cap slowly.** Never remove fuel filler cap while engine is running.

Select bare ground for fueling, then move at least 3 metres (10 feet) from the fueling spot before starting the engine. Wipe off any spilled fuel before starting your Atom unit and check for leakage.

Always tighten fuel filler cap securely after fueling.

! WARNING Always allow engine to cool before refueling. Accidental spillage of petrol over hot engine could cause fire or explosion to occur with consequent possible disfigurement or fatal injury. Wash and clean hands after fueling.

⚠ WARNING Battery tool use and care

Only recharge with the Atom charger. When battery pack is not in use, keep it away from other metal objects. These could short out battery and cause fire. Do not put battery or machine near fire or heat. Keep away from water as risk of electrical shock.

Under abusive conditions, liquid may be ejected from the battery; avoid contact. If contact accidentally occurs, flush with water. If liquid contacts eyes, additionally seek medical help. Liquid ejected from the battery may cause irritation or burns.

ASSEMBLING ///ATOM® AIRLIFT BLOWERS

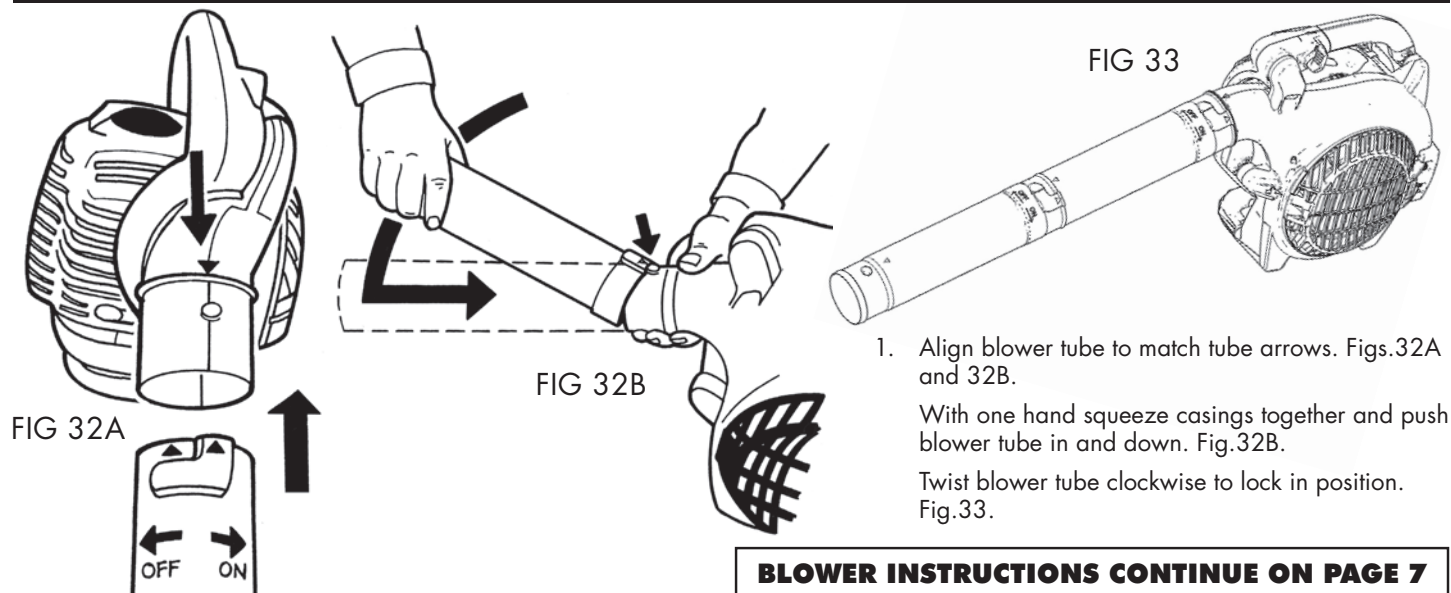

BLOWER INSTRUCTIONS CONTINUE ON PAGE 7

ASSEMBLING ///ATOM® DRILLMASTER ENGINE DRILLS

Use Torx 25 screwdriver or straight blade screwdriver. Fit 7 screws M5 x 36mm (supplied) to assemble as follows:

1. Fig.35. Unit shown without main support handle.
2. Fig.36. Fit LH main support handle #8 into casing. Insert screws #1 and #2 and tighten. Fit handle grip #10 with screw #3 to LH support handle #8.
3. Fig.37. Carefully slide labelled Handle Rib #11 into top and bottom groove in LH handle #8.
4. Fig.38. Insert screws #4, #5 and #6 and tighten. In LH handle #8 screw centre bracket together with screw #7.

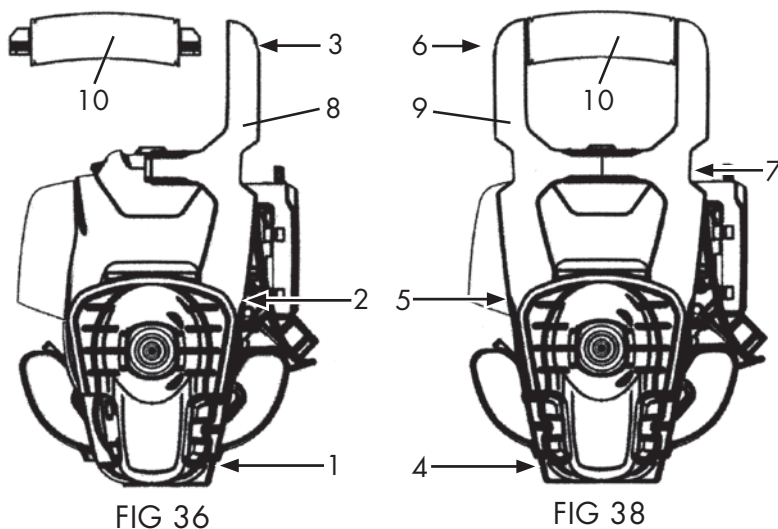

⚠ WARNING Check that all screws #1-#7 are tight.

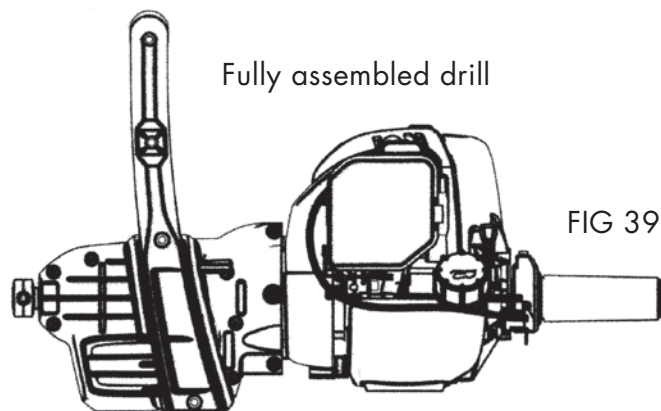

DRILL INSTRUCTIONS CONTINUE ON PAGE 7

ASSEMBLING LAWN EDGERS & TILLERS

1. Fig. 10. Using blade screwdriver (or Torx-25 screwdriver). Use M5 x 36mm screws #8 to screw 2 handle tubes #3 & #5 to cross brace #7.

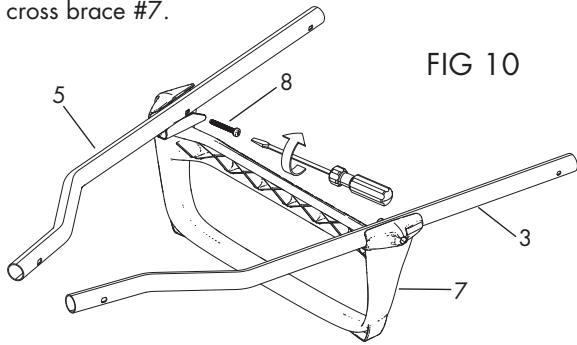

2. Fig. 11. Place lawn edger or tiller body on bench or floor **with approximately 75mm-100mm (3"-4") spacer under motor**. Fit handle tubes assembled with cross brace #7 to edger or tiller body as shown with bolt #1 and tighten large plastic wing nut #6. **FOR PROFESSIONALS**, firstly put front ends of tubes through AV rubbers #7 & #8 in Fig.7 on page 5.

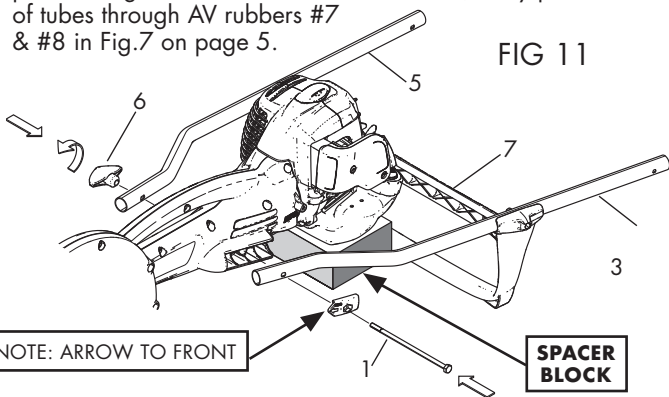

3. Fig. 12. Looking down from rear of edger or tiller, feed RH hand grip #11 with throttle trigger, throttle cable and switch wire #10 under engine, and over top of cross brace #7 and push RH trigger hand grip #11 onto end of RH handle tube #5. (Note battery edgers/tillers have no (separate) switch wire). Then also push LH hand grip #13 onto end of LH handle tube #3.

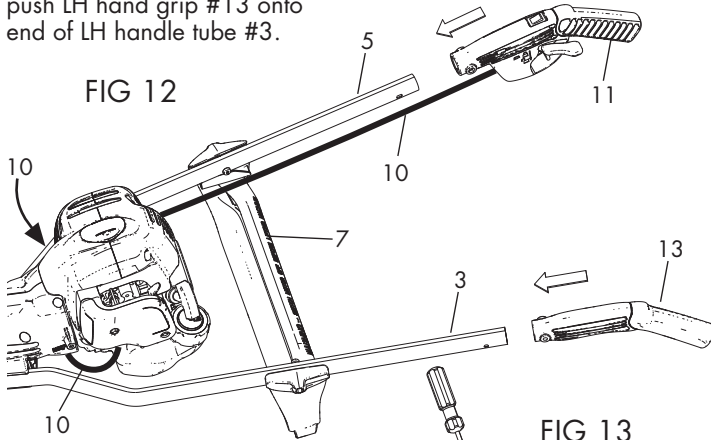

4. Fig. 13. Fit and hold M5 loc-nut #9 (with nylon part of nut facing away from tube) into hex recess of hand grip and insert M5 x 36mm #8 through hand grip (from other side), through tube and tightly screw up. Repeat for other hand grip.

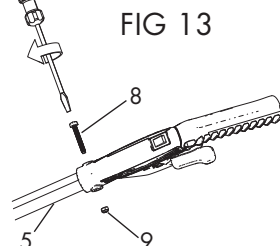

5. Figs. 14 and 15. Clip throttle cable and switch wire #10 into place.

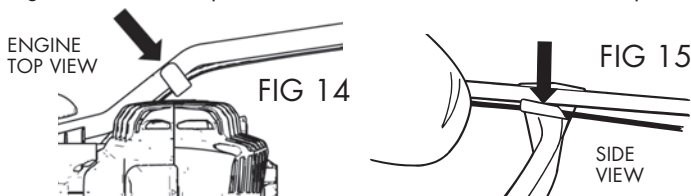

WHEEL ARM ASSEMBLY

- Fig. 19. **LAWN EDGERS** On LH side insert M5 x 36mm screw #8 through fixed encapsulated washer #26, and tighten screw.

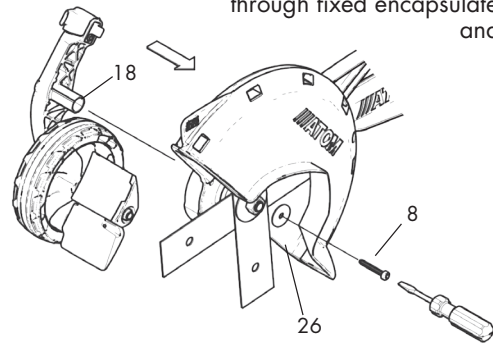

EDGER INSTRUCTIONS CONTINUE PAGE 5 & 6

TILLERS

- Fig. 20. Insert bolt #15 into wheel arm, and on LH side (if not already fitted) fit o-ring #24 and washer #16 and nut #17 onto protruding bolt. **Fully tighten nut.**

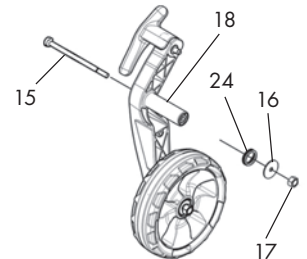

TINES ASSEMBLING FIG 21

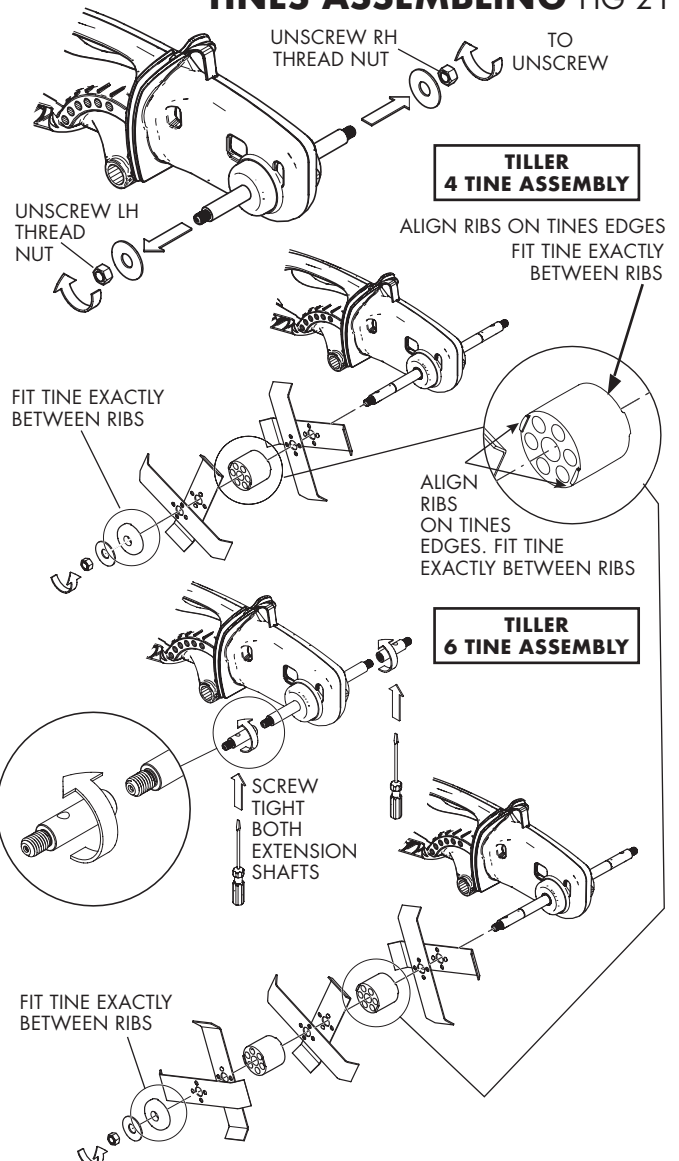

TILLER INSTRUCTIONS CONTINUE PAGE 6

ASSEMBLING ///ATOM® PROFESSIONAL EDGER

1. Fig.8. Undo 2 screws #1. Fit AV handle supports #2 & #3 by pushing fully into each side of the body #4.
2. Re-fit screws #1 through #2 and into #3 and screw tightly.
3. See page 4 Fig.10 and 11 instructions for easy assembly of handles to cross brace with spacer block under motor.
4. Fig.7. Fit handl tubes through round AV rubbers (in AV handle supports).
5. Tighten handle knob #11 but DO NOT OVERTIGHTEN as AV becomes less effective.
6. To fit RH & LH handle grips, follow page 4 instructions 3, 4, 5 and 6.
7. Fit wheel arm as in page 4, Fig 19.
8. When assembled, unit will look like Fig. 9.

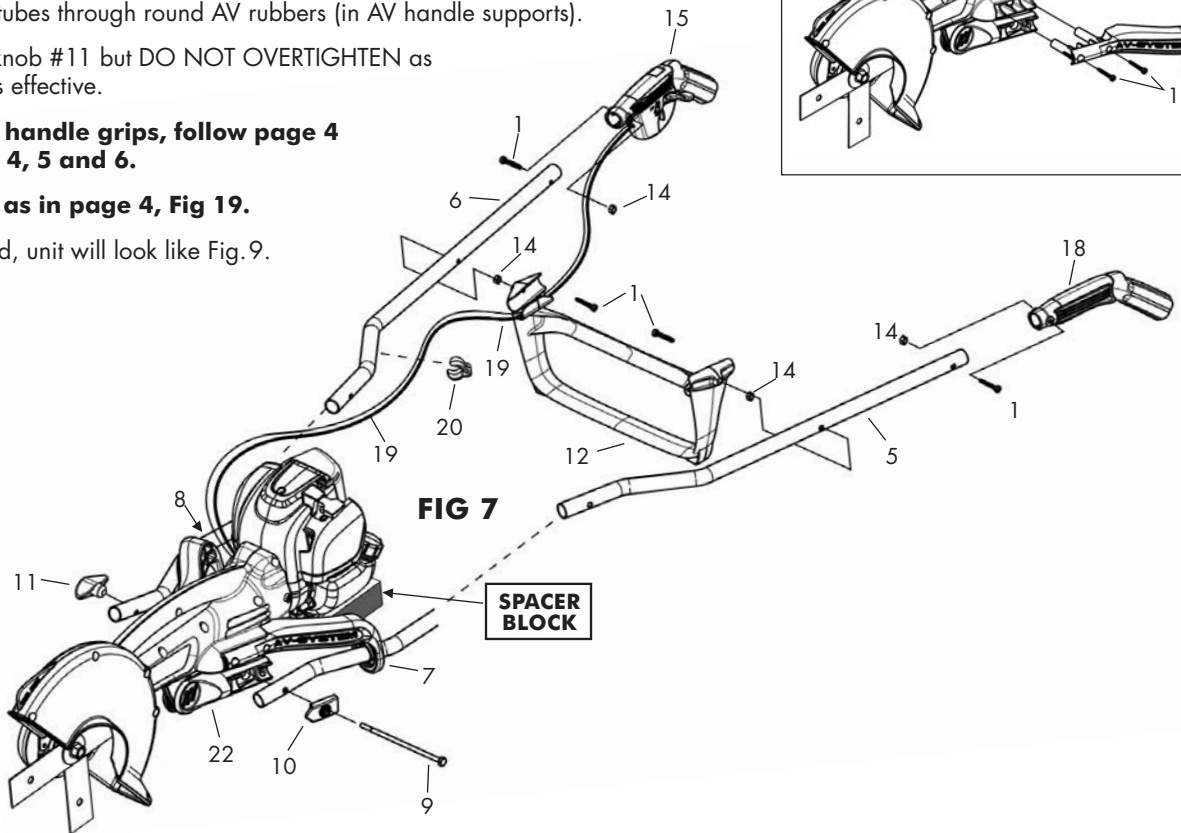
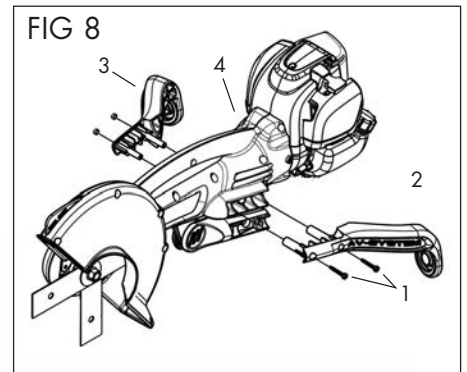

PARTS & CONTROLS ///ATOM® PROFESSIONAL EDGER

- 1+2. Each handle grip of the edger are held by each hand at all times.
3. The throttle interlock which releases the throttle trigger which increases the speed of the automatic safety clutch to engage and thus rotate blades.
4. Handle knob for holding handles onto housing.
5. Depth adjustment for adjusting wheel to regulate blade depth. Try hole 3 of 4 for first edging attempt.
6. Handle to carry edger.
7. Blade cover reduces the risk of flying debris and direct contact with the feet or hands.
8. Blades rotate when engine speed is increased above idle.
9. Nut for holding blades (RH thread).
10. Wheel for moving and guiding edger.
11. Cross Brace, attaches downward on handle tubes.
12. Handle Tubes (x2).
14. Main anti-vibration system.
15. Fuel tank.
16. Carburettor primer.
17. Ignition ON/OFF switch.
18. Fuel tank cap.
19. Oil filter and dip stick for 4-Stroke.
20. Edge guide.

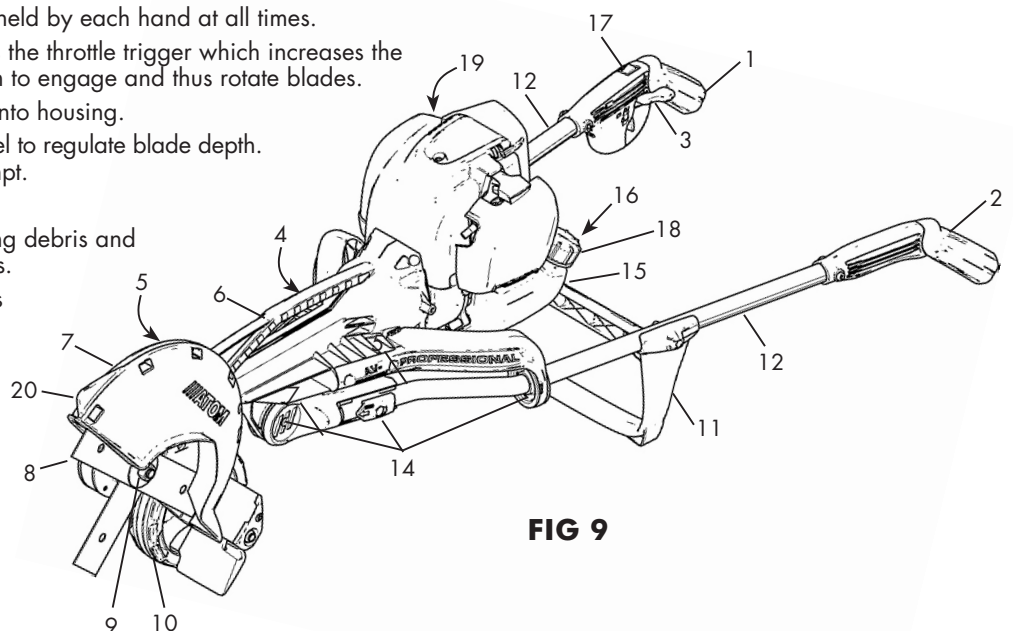

**PROFESSIONAL EDGER INSTRUCTIONS
CONTINUE PAGE 9**

PARTS & CONTROLS: ///ATOM EDGERS & TILLERS

PETROL EDGER

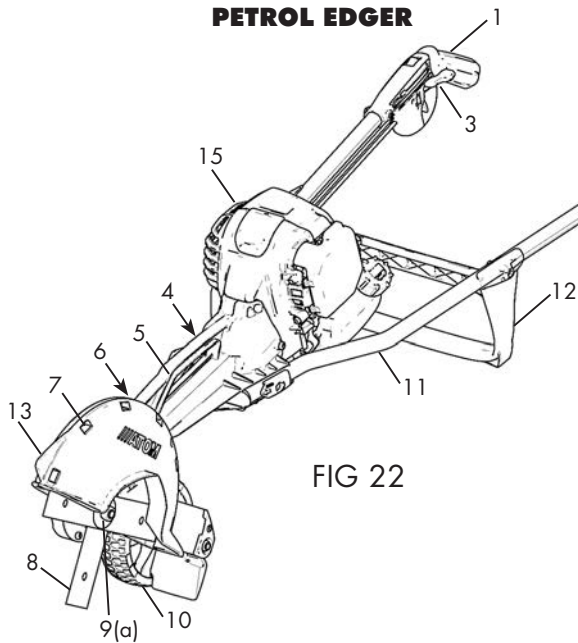

FIG 22

BATTERY EDGER

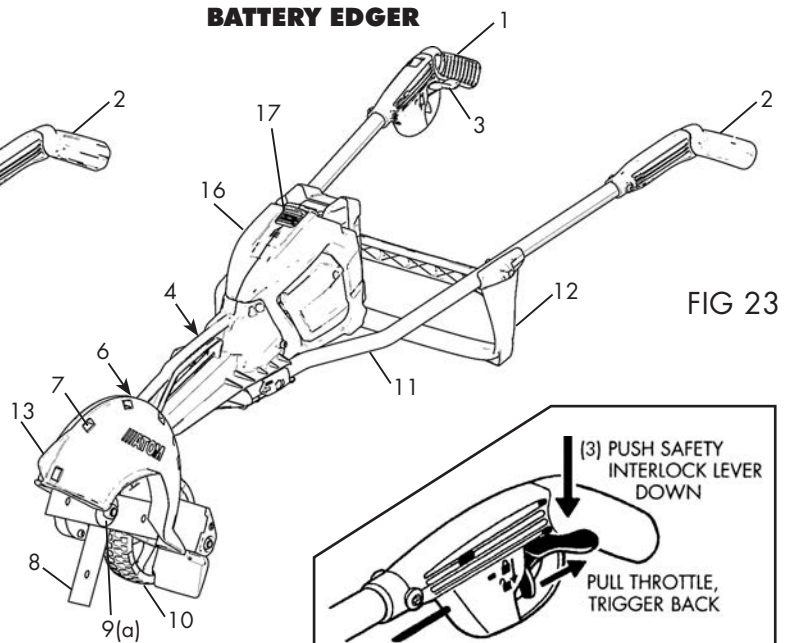
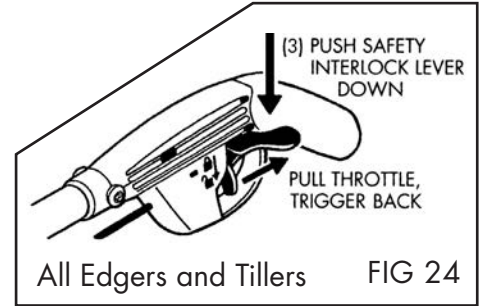

FIG 23



All Edgers and Tillers FIG 24

- 1+2. Each handle grip of edger & tiller are held by each hand at all times during use.
- 3. Throttle interlock releases throttle trigger to increase speed of engine for automatic clutch to engage and rotate blades or tines.
- 4. Handle wing nut for holding handle tubes onto housing.
- 5. Machine lifting handle.
- 6. Wheel arm handle for adjusting wheel height/depth.
- 7. Cover reduces the risk of flying debris and direct contact with feet or hands.
- 8. Blades or Tines rotate when motor speed increases.

- 9 (a) Nut for holding blades or tines (RH thread).
- (b) Tiller only – LH nut holding tines.
- 10. Wheel for moving & guiding machine.
- 11. Handle tube (x 2).
- 12. Cross brace; attaches downward on handle tubes.
- 13. Edge guide (edgers only).
- 14. Lift knob and twist to remove cover (tillers only).
- 15. Petrol motor. See page 5 Pro Engine items 15 – 19.
- 16. Brushless motor pod and battery.
- 17. Battery lock – pull towards battery to release.

PETROL TILLER

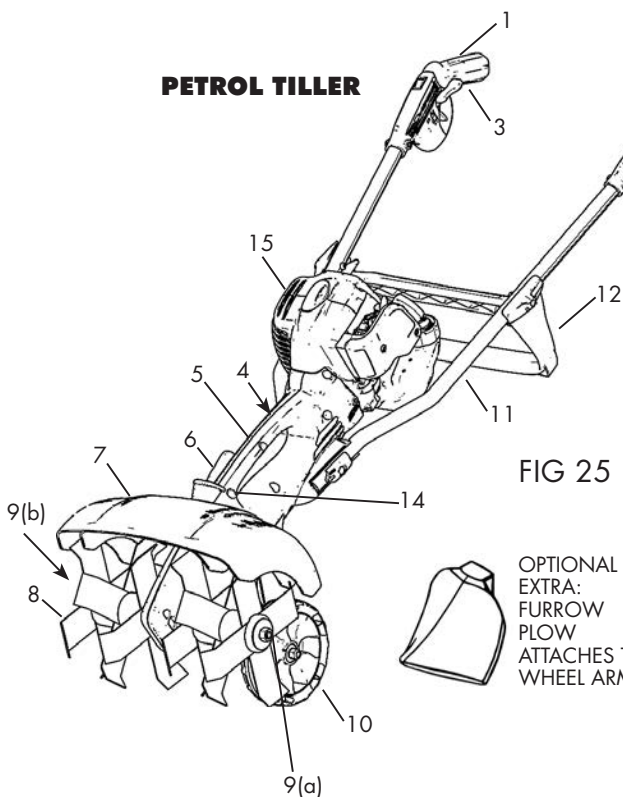

FIG 25

BATTERY TILLER

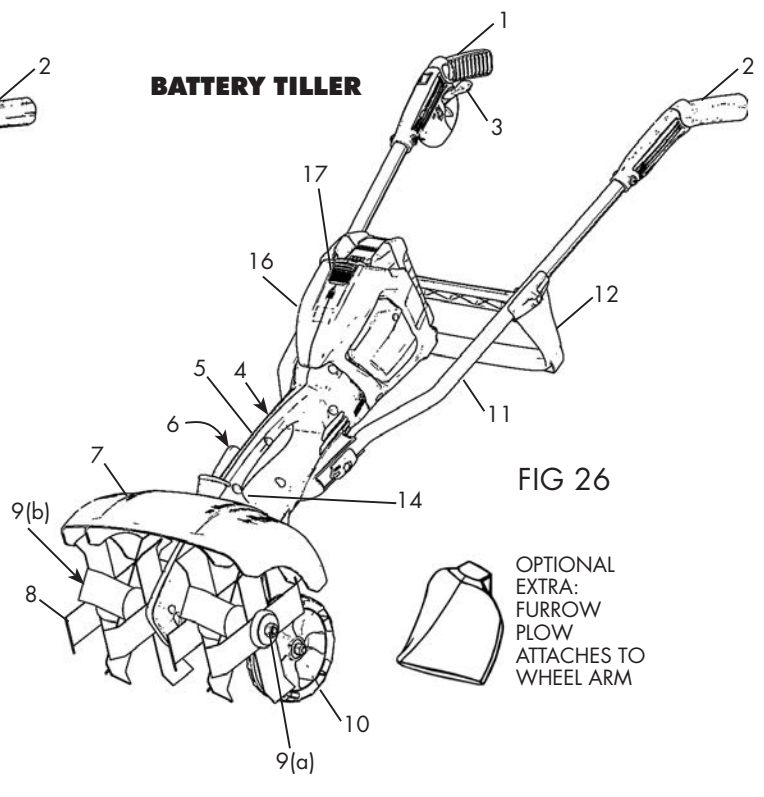

FIG 26

OPTIONAL EXTRA: FURROW PLOW ATTACHES TO WHEEL ARM

OPTIONAL EXTRA: FURROW PLOW ATTACHES TO WHEEL ARM

PETROL EDGER & PETROL TILLER INSTRUCTIONS CONTINUE PAGE 9

BATTERY EDGER AND BATTERY TILLER INSTRUCTIONS CONTINUE PAGES 11-13

PARTS & CONTROLS: ///ATOM® PETROL & BATTERY BLOWERS

PETROL 2 AND 4-STROKE MODELS

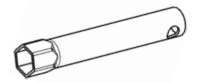
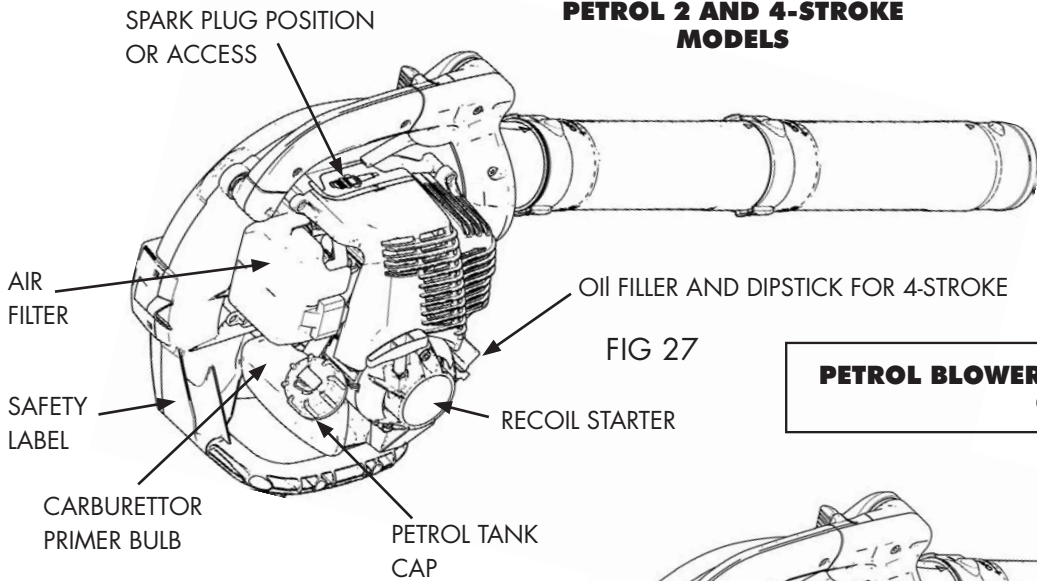

SUPPLIED 4-STROKE SPARK PLUG TUBE SPANNER

PETROL BLOWER INSTRUCTIONS CONTINUE ON PAGE 9

BATTERY MODEL

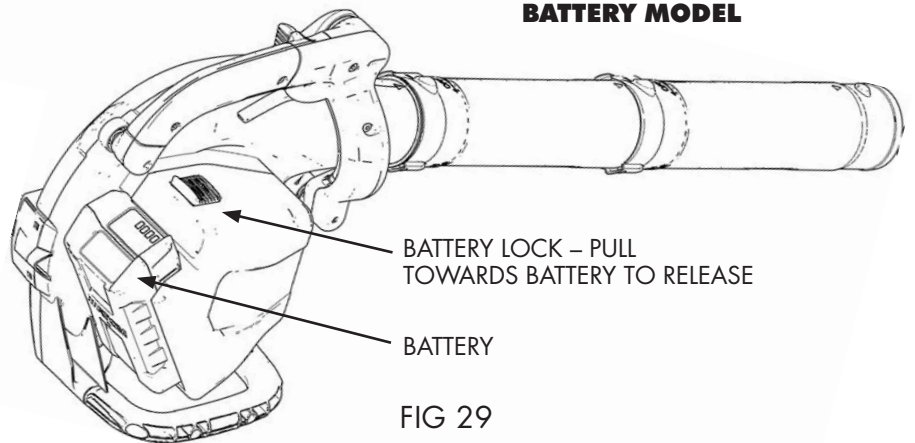

CRUISE CONTROL ALL MODELS

REARWARDS FOR CRUISE & FORWARD FOR PETROL SWITCH OFF

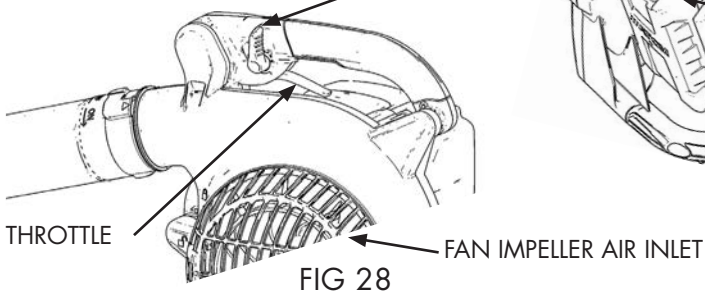

BATTERY BLOWER INSTRUCTIONS CONTINUE PAGES 12 AND 14

PARTS & CONTROLS: ///ATOM® ENGINE DRILLS

Auger 10 shown is extra. Operator to select sizes to suit holes to be drilled.

- 2 Locking collar with grub screw to secure auger
- 3 Gear box
- 4 Gripping and carrying handle
- 5 Engine
- 6 Recoil starter – to start motor
- 7 ON/OFF switch to stop motor.
- 8 Motorcycle type twist grip handle and throttle control. Twist to left (anti-clockwise) to increase engine speed.
- 9 Fuel tank cap

- 10 Auger rotates in right hand (clockwise) direction when drilling. If drill unit is pulled back auger rotation reverses (anti clockwise) and screws out. When pressure on auger is released, auger automatically rotates in right hand (clockwise) direction.
11. Holding nest for grub screw Allen Key to lock/unlock collar and auger.
12. Carburettor primer bulb.

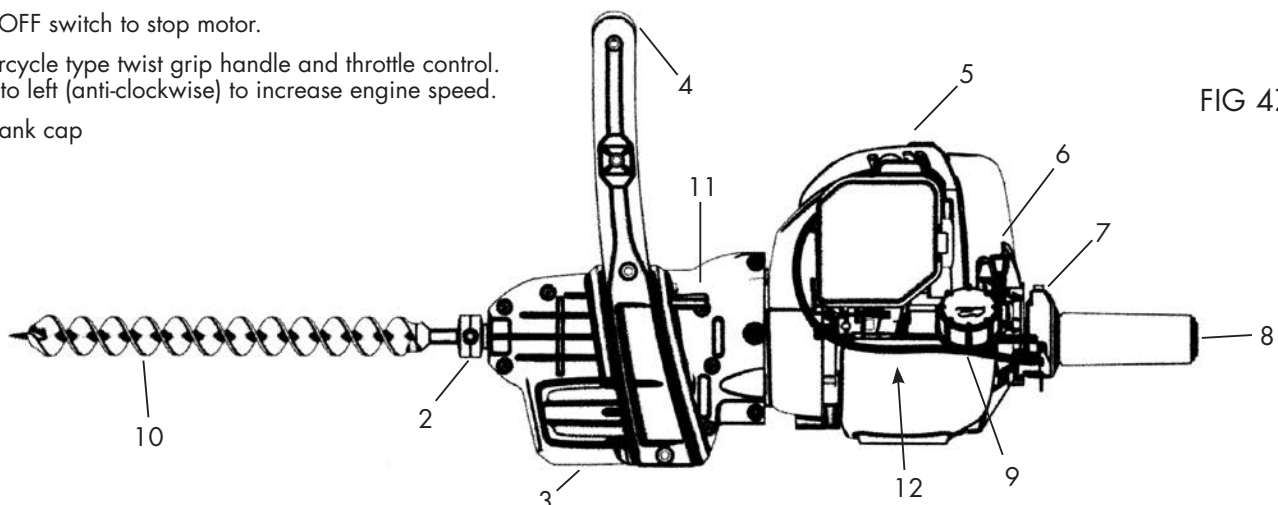

DRILL INSTRUCTIONS CONTINUE ON PAGE 9

BATTERY STRING TRIMMER ASSEMBLY, PARTS & CONTROLS

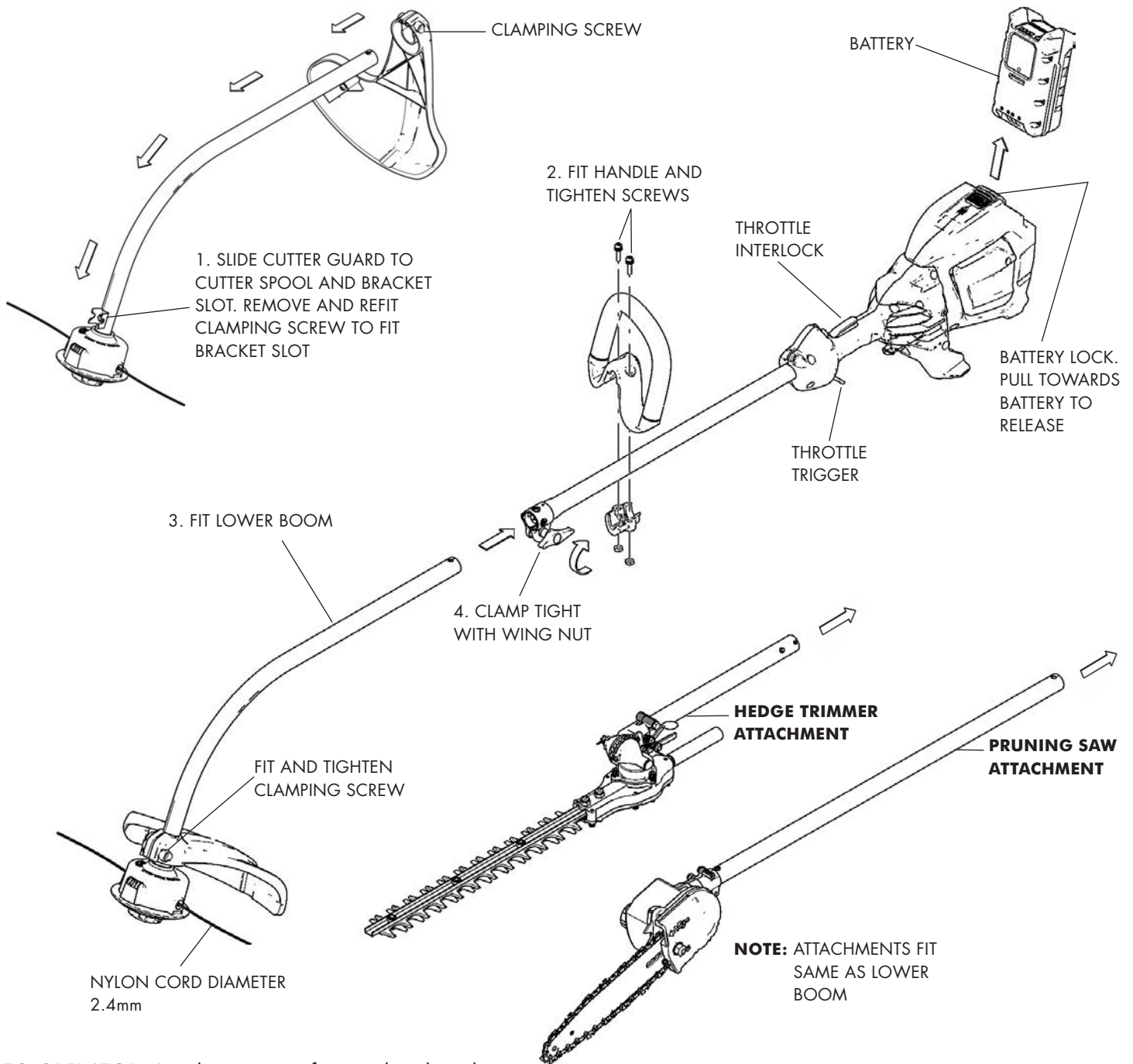

TO OPERATOR: Accelerate motor for spool and cord to spin at speed to slash vegetation. To lengthen cords, bump head on ground with spool spinning. Cords automatically cut to size.

TO REFILL SPOOL

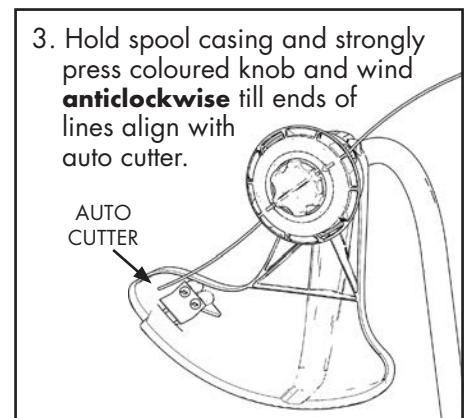
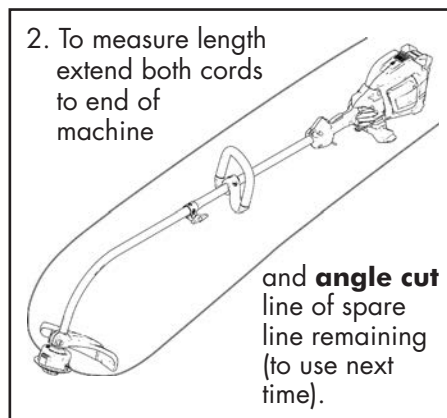
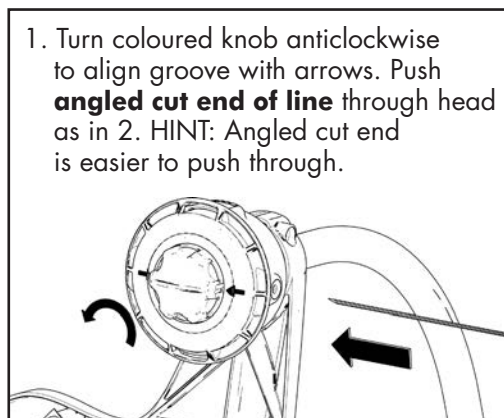

**BATTERY TRIMMER INSTRUCTIONS
CONTINUE PAGE 12**

FUELS & OILS: ALL PETROL MODELS

⚠️ WARNING DANGER!

Fuel is extremely flammable. Handle it with care. Keep away from ignition sources. Do not smoke while fueling your equipment.

⚠️ WARNING Always allow engine to cool before refueling. Accidental spillage of petrol over a hot engine could cause fire or explosion to occur.

FUEL MIX – 2 STROKE ENGINES

IMPORTANT USE AN OIL AND PETROL MIXTURE.

Only use 50:1 specialised 2-stroke oils from lawn and garden equipment shops. Do not use outboard engine oil.

REMEMBER...

- Always mix two-cycle oil with petrol before fuelling your engine. Never, ever run your 2-stroke engine on petrol alone. This will ruin your engine and void all warranties.
- Always use a clean gas can and always use non Ethanol fuels. Ethanol (E-10) can absorb water and hence cause problems.
- Never try to mix the oil and petrol in the engine fuel tank.
- **Always mix oil and gas 50:1 in the proper proportions: 80ml of 50:1 two-cycle engine oil to 4 litres of unleaded petrol.**

! NOTE 2-Stroke engines can operate with fuel mixes from 25:1 to 50:1. We recommend 50:1, which is 1 litre of unleaded petrol to 20ml (cc) of 50:1 good quality 2-stroke oil. For 4 litres fuel add 80ml (cc) of oil. **DO NOT use 2-stroke oils that claim to use less oil (eg. 100:1).**

- Two-cycle fuel separates and ages. Do not mix more than you will use in a month. Using old fuel can cause difficult starting or engine damage. Shake fuel container to thoroughly mix fuel before each use. Do not attempt to run your 2-Stroke engine on Petrol only, this will cause engine failure and void engine warranty.

⚠️ WARNING Fill or add fuel to the tank only when the machine is in a horizontal position as typically shown for all models in Fig. 51. Allow engine to cool down for at least 5 minutes before adding fuel. Use fuel funnel (not supplied) to prevent spills. Do not spill fuel over top of tank as it will be splashed into motor air cooling system or the air filter system.

⚠️ WARNING Never store the machine with Petrol inside a building where fumes may reach an open flame or spark (e.g. gas or oil-fired heater appliance, electric motor, etc.)

Before storing for a longer period, always empty the fuel tank.

⚠️ WARNING The engine exhaust from this product contains chemicals known to the State of California to cause cancer, birth defects or other reproductive harm.

⚠️ WARNING Pressure may build up in the canister. Remove fuel cap slowly to avoid injury from fuel spray. Replace fuel cap securely. Take care when handling Petrol. Avoid direct contact with the skin and avoid inhaling fuel vapor.

Before unscrewing fuel tank cap to fuel the engine, clean the tank's cap and area around it to ensure that no dirt falls into the tank.

FUEL – 4 STROKE ENGINES

- Use clean, fresh unleaded petrol (not ethanol).

Note: DO NOT use 2-Stroke fuel (oil/petrol mixture).

- Use clean 4-Stroke automotive detergent oil or SAE 10-30W mineral oil. Fill crankcase to correct level.

WARNING Using synthetic oil, or 2 stroke oil, in crankcase will shorten engine life.

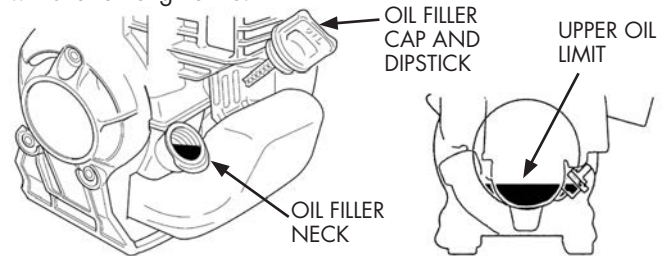

FIG 50A

FIG 50B

- **ALWAYS** check your oil every first or second fuel fill. Regular check of oil levels is essential. Change oil after first 5 hours then every 30 hours. Lack of oil or infrequent change of oil will destroy engine.

⚠️ WARNING A worn or damaged muffler is a fire hazard and may cause loss of hearing. Check to see that the muffler is in good condition.

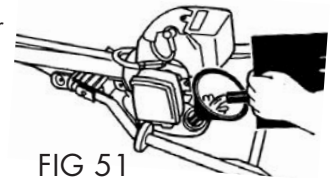

FIG 51

Always filter fuel when refuelling.

Check fuel filler cap for leaks at regular intervals. Use the specified spark plug and make sure it and the ignition lead are always in good condition.

⚠️ WARNING Start and operate your unit outdoors and in a ventilated area.

Keep the space behind and beside the engine clear at all times to allow for the escape of hot and toxic exhaust fumes.

Operate your machine under good visibility and daylight conditions only. Work carefully.

Never touch a hot muffler as burns will result. Store Atom product in a dry, high or locked location and out of reach of children.

GEAR LUBRICATION

EDGERS: There is sufficient lubrication to last the lifetime of the unit except for professional edger use, grease every 50 hours—use grease bottle P/N 43227. Refit grease cover by placing its 2 spigots into both holes before tapping cover to secure.

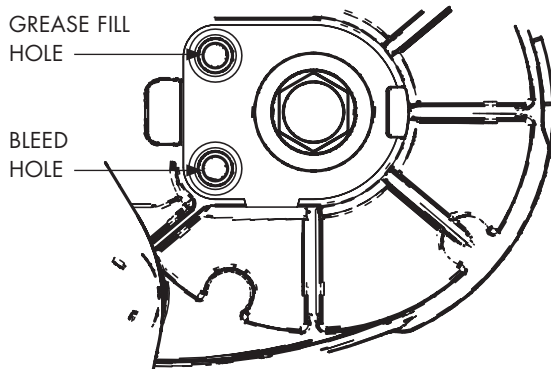

To remove grease cap refer to page 16 Fig.78

! NOTE Ensure grease cap is fitted at all times otherwise gear damage can occur.

TILLER & ENGINE DRILL:

TILLER: Every 5 hours remove filler screw and squeeze in quarter bottle grease. Page 16, Fig.84.

DRILL: Every 10 hours. Page 17, Fig.89 and Fig.90

STARTING & STOPPING INSTRUCTIONS: PETROL EDGERS & TILLERS

CHOKE ON POSITION

- ZENOAH G26L,
- HONDA GX35
- MITSUBISHI TLE33 & TLE48

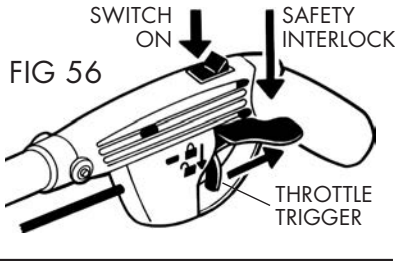
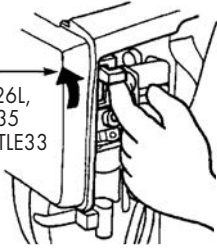

Place edger or tiller on ground in horizontal position. See Fig. 55 below.

COLD START

1. Switch ignition switch ON (Fig. 56). Engine starts at idle.
2. Slide choke lever to full choke ON position ① in Fig. 57.
3. Press and release the primer bulb 6-10 times. For first time starting of new unit, press primer bulb twenty times to remove all air from carburettor.
4. Make sure you have a firm footing. Hold down motor with left hand. With right hand pull the starter grip slowly until you feel it engage – and then give it a quick pull.
5. When engine starts to run allow it to run on half choke for a few seconds to warm up ②, then push choke off to engine run position ③.
6. Throttle Trigger (engine accelerator control) is operated by pushing down interlock with thumb and pulling on trigger (Fig. 56).

WARM OR HOT START

7. Switch ignition on and follow instructions 3 & 4 only (no choke).

FLOODED ENGINE

8. Ignition ON, choke lever OFF in run position ③.
9. Pull starter rope up to 10 times to clear excess fuel.

10. If engine has excessive fuel that cannot be cleared, remove spark plug from engine and from spark plug terminal, crank engine to clear excess fuel, wipe and dry spark plug of all fuel, re-install spark plug, terminal, and restart as above. Otherwise allow to stand for 30 minutes before restarting.

FIG 55

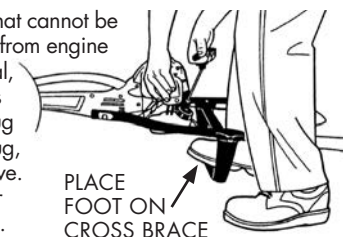

PLACE FOOT ON CROSS BRACE

FIGS 57 ALL ENGINES CHOKE POSITIONS

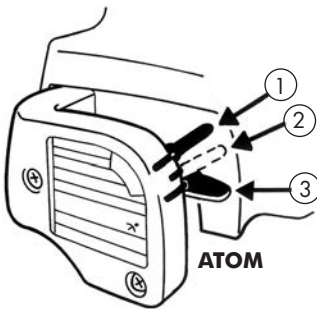

ATOM

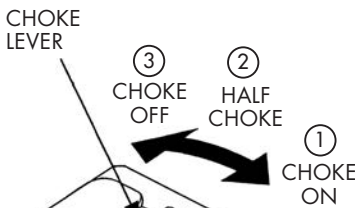

HONDA GX25

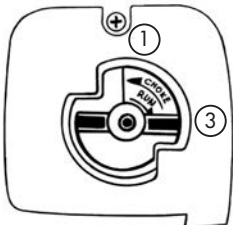

MITSUBISHI TLE33 (Also above)

**PETROL EDGERS INSTRUCTIONS CONTINUING ON PAGE 11.
TILLER INSTRUCTIONS CONTINUE ON PAGE 13.**

STARTING & STOPPING INSTRUCTIONS: AIRLIFT PETROL BLOWERS

Atom 2-Stroke and Atom 4-Stroke Honda powered Blowers start on idle, run and stop in a similar manner.

COLD START

1. Press and release the primer bulb 6-10 times. (20 times if first time for new unit) Slide choke to full CHOKE ON position. ① Fig. 57.
2. Place foot next to lower handle and hold upper handle down firmly with left hand. With right hand pull the starter grip slowly until you feel it engage – and then give it a quick pull.
When engine starts to run allow it to run on half choke for a few seconds to warm up ②, then push choke off (position ③) for engine to run.

HOT START

As above in 2.

CRUISE CONTROL

To use cruise control pull throttle trigger and move cruise control rearward. To release cruise control move lever forward to UPRIGHT POSITION or STOP MOTOR position (extra forward) Fig. 59.

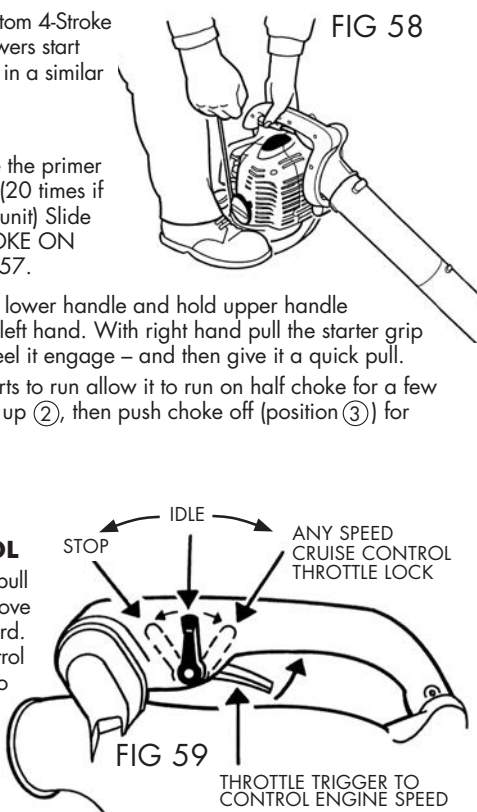

FIG 58

FIG 59

STARTING & STOPPING INSTRUCTIONS: DRILLMASTER ENGINE DRILLS

All engine types fitted to Atom Drills start and stop in a similar manner. Please follow instructions above for starting Petrol Edgers and Tillers with the exception of Clause 6.

Switch ignition switch ON.

Place Engine Drill on clear ground. Hold down firmly with left hand on top of motor. With right hand on recoil starter handle pull rope until firm, then give it a fast pull. The Engine will start on idle.

To increase engine speed twist rear throttle handle (anti-clockwise)

Switch OFF ignition switch to stop engine.

Place **CUP OF HAND UNDER** throttle handle to operate throttle. Fig. 60 & Fig. 60A.

Warm up engine for one minute before drilling.

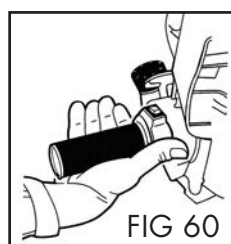

FIG 60

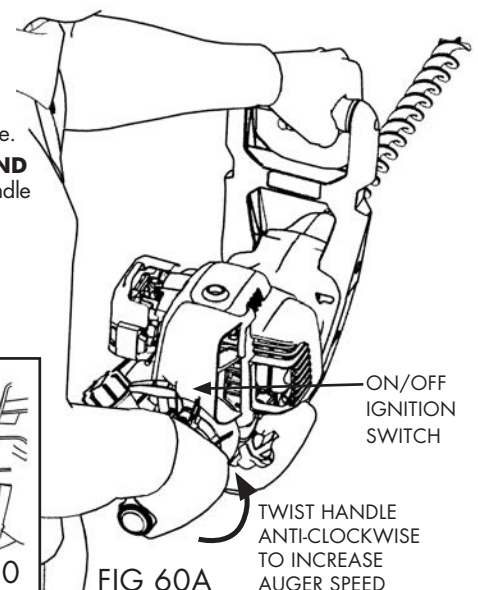

FIG 60A

BLOWER INSTRUCTIONS CONTINUE ON PAGE 14

DRILL INSTRUCTIONS CONTINUE ON PAGE 14

OPERATING INSTRUCTIONS: EDGERS ALL MODELS

1. Read all safety instructions and assemble unit according to this Manual. Select an open area of lawn or clear ground to do a test run. Place unit on ground.

2. Adjust height adjustment of wheel arm to No. 4 for average height or No. 3 for taller persons.

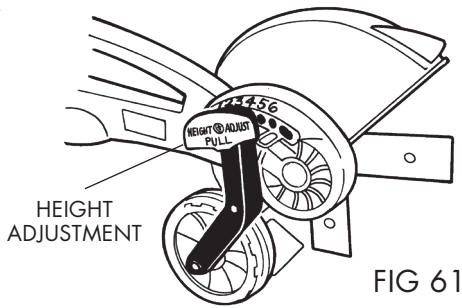

FIG 61

3. If petrol engine, start motor (see page 10) and allow engine to warm up.

! NOTE

A built in automatic centrifugal clutch disengages the blade from rotating when throttle trigger is released. The clutch engages the blades when the motor is accelerated with the throttle trigger.

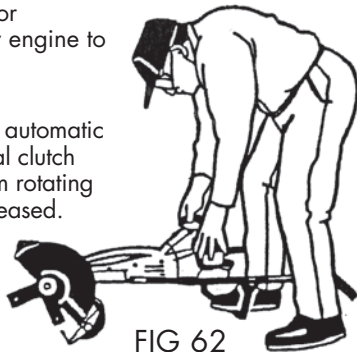

FIG 62

4. As you pick up handles, push down interlock with thumb and pull trigger fully, **accelerating engine to full speed.** Like any cutting tool, the blades must be spinning before it starts slicing.

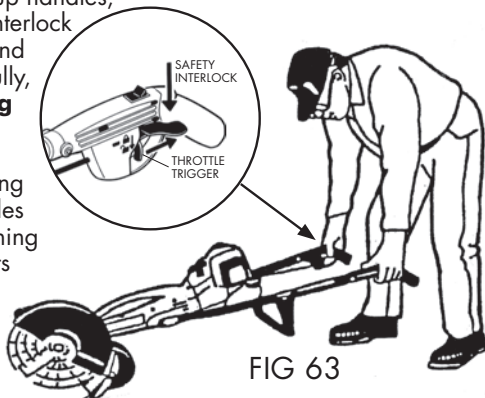

FIG 63

5. **Keep engine running at full speed** with spinning blades cutting into ground **at shallow 10mm -15mm depth.** It is always more comfortable and relaxed to have arms fully extended downwards.

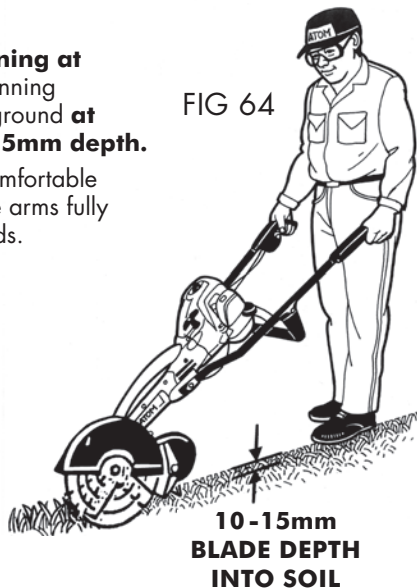

FIG 64

6. **Blades must always spin when motor is running.** If blades have stopped spinning and engine is running you could damage the unit and **warranty will not apply.** Fig.64.

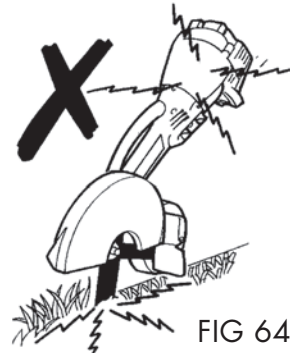

FIG 64

7. **With engine running at full speed** gradually move forward **ensuring blades are spinning and cutting shallow groove 10mm -15mm** in ground. If blades are not spinning (you are cutting too deep), lower handles or adjust wheel height to a lower number to enable blades to spin. Fig.65.

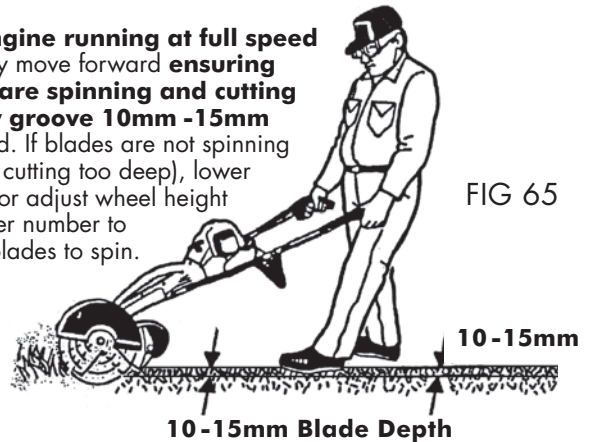

FIG 65

8. Even with the grass growing over the concrete and you cannot see the edge, you can feel the edge of the concrete with the spinning blades by **sideways tilting** the handles of the edger away from the concrete so that the blades tilt towards the concrete and skim below the concrete edge which acts as a guide (Fig 66). Edger blades are made from high tensile hardened spring steel and will last a long time. Once the edge is established the second and subsequent times are very fast.

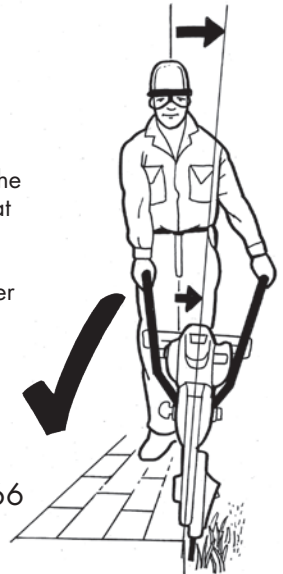

FIG 66

9. Sideways Tilting: Lower either left or right handle to achieve moderate but deeper angle cutting (Fig 67).

HINT: This moderate tilt angle can also be used slowly against a flat tiled path edge to ensure tiles are not contacted by blade. The result is a nice tidy wide clean edge.



FIG 67

EDGER OPERATING INSTRUCTIONS CONTINUE ON PAGE 12

OPERATING INSTRUCTIONS: EDGERS ALL MODELS

! WARNING To avoid personal injury, never carry the Edger while the motor is running. Never hold the handle cross brace if the motor is running (Fig. 68) Stop the engine prior to lifting or carrying. If electric edger then also disconnect extension cord.

FIG 68

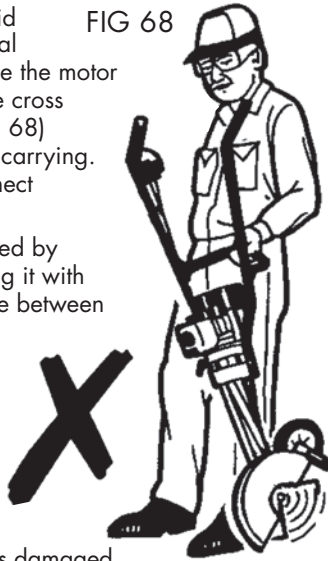

The Lawn Edger can be transported by guiding it on its wheel, or carrying it with motor switched off holding handle between blade cover and motor.

SAFE WORKING INSTRUCTIONS AND IMPORTANT ADJUSTMENTS

Never operate your machine if it is damaged, improperly adjusted or not completely and securely assembled.

At correct idle speed, the blade should not turn. Do not use the Atom Edger with incorrect idle speed (refer Adjusting the Carburettor instructions on page 19).

For battery edger do not use if switch does not turn on or off properly (see page 3).

! NOTE Keep the inside of blade guard clean, especially in muddy conditions. A clogged guard can slow down or stop blade rotation and may cause damage to automatic safety clutch. Always operate blades **spinning** at high speed when edging.

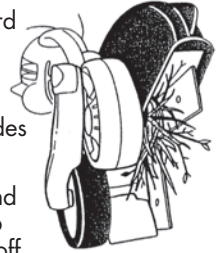
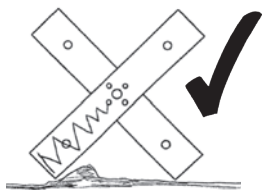

FIG 69

! WARNING Always stop the engine, or remove battery, make sure that the blade is stopped before adjusting blade height, doing any maintenance or repair work, or cleaning the unit or blade.

! WARNING USE OF NON ATOM EDGER BLADES IS DETRIMENTAL AND VOIDS ANY WARRANTY.

USE ONLY ATOM 2 PIECE CROSS BLADES



ATOM BLADES ABSORB SHOCK

Atom twin Cross Blades absorb shock and excessive loading and have been proven over 15 years as the only blades compatible with the Edger gear system to guarantee long life.

DO NOT USE ANY ONE PIECE SOLID BLADE

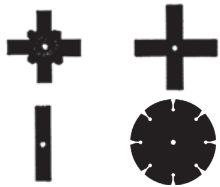

These types of blades should NOT be used on any model Atom Lawn Edger due to heavy mass weight, thickness of blade/out of balance, warping creating vibration and overloading of the gear mechanism of Atom Edgers.

These non-genuine blades do not absorb shock, which is taken by the Edger gear system causing subsequent damage. A safety issue may arise as solid one piece blades are heavier and take longer to stop spinning when motor is turned off or reduced to idle, due to heavier weight and flywheel effect.

USE ONLY ATOM 2 PIECE CROSS BLADES

Beware of blades advertised as Atom Blades, or "superseded by", "replaces", etc being "passed off" as Atom Blades. This is a trademark infringement, and are false and misleading statements.

All model Atom Edger Blades are supplied in a sealed white plastic pack branded ATOM with clear instructions on "How to fit" and promoting other Atom products on the reverse side. Any other packaging not as above, are not genuine Atom product, and, if used on Atom Edgers, will be detrimental and void any warranty.

Remove nut anti-clockwise, one large washer and two blades (Fig. 80). Before installing blade and washers, clean off all grit and grease. Re-assemble these parts clean and dry. Fit large washer, new blades #43105 with spiggots of one blade interlocking with holes on opposite blade, large washer and nut. Tighten nut to 15-20ft.lbs. (20-27Nm) or hand tight with 8" (200mm) or longer spanner.

FIG 80 FITTING INSTRUCTIONS

FIT BLADES AT RIGHT ANGLES
2 SPIGOTS ON EACH BLADE
FIT INTO HOLES OF OTHER BLADE

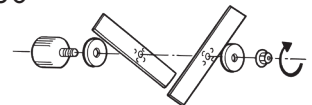

! NOTE Always use two blades as shown above. Never use a single blade or other thicker blades as you will damage the unit.

CHARGING BATTERY FOR ///ATOM BATTERY POWERED PRODUCTS

LIGHT INDICATORS ON CHARGER

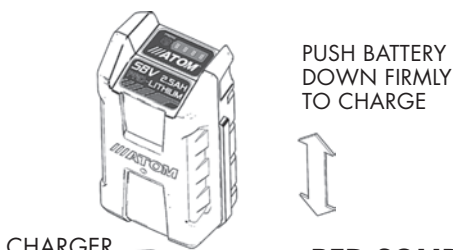

PUSH BATTERY DOWN FIRMLY TO CHARGE

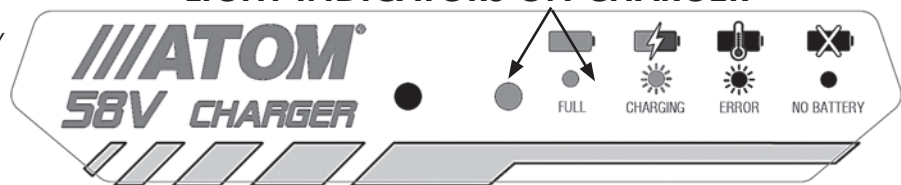

- RED SOLID** = Mains power on without battery.
- RED BLINKING** = Battery hot or battery malfunction. Remove hot battery until battery cools down.
- GREEN BLINKING** = Battery charging.
- GREEN SOLID** = Battery fully charged.

When machine not in use remove battery. Battery may discharge if unused for period of time. Best to top up charge before using for maximum run time.

BATTERY & BRUSHLESS MOTOR INFORMATION page 20

OPERATING INSTRUCTIONS: TILLERS ALL MODELS

1. The Atom Tiller is very easy and simple to use. It only takes a few minutes to become an efficient user.
2. Thoroughly inspect the area where the tiller is to be used and remove all long grass, stones, sticks, wires and other foreign objects. Give the ground and little watering to soften the ground and keep dust down.

! NOTE Before tilling, grass must be cut very low to the ground (and removed) with lawnmower or string trimmer/brush cutter to prevent fine grass strands from tangling around and under tine drum.

3. Adjust tine depth (Fig.70 or 71). Try the third hole closest to operator.
4. Start motor and, with both arms fully extended downwards, (Fig. 72), hold both handle grips firmly.
5. As tilling action begins, the tines dig and move the tiller forward.
6. **NOTE:** to reduce "Forward Pull" of tiller, adjust wheel arm for shallower depth.
7. Continue at a moderate pace until you are familiar with the controls and handling of the Atom Tiller.
NOTE: after allowing the tiller to cultivate 500mm you can pull it back towards you and then allow the unit to move forward again. You can repeat this procedure over the area you are cultivating. Always have a firm footing.
8. Mulching. The tiller is ideal to mix, cut lawn clippings, leaves etc into your garden bed. This method accelerates mulching/composting process.
9. To go deeper adjust wheel arm adjustment forward or lift handles. To go shallower adjust wheel arm adjustment rearwards or push handles down.

! WARNING Operate unit carefully. Be very careful walking backwards as you may trip, fall and injury yourself. Always have a firm footing.

! NOTE The Atom Tiller is not designed for large areas where heavier duty equipment should be used.
If you cannot push a spade into the ground, then the ground is too hard.

Very hard ground, clay or rocky conditions: The Atom rotary tiller is NOT DESIGNED for very hard ground, hard or rocky conditions. These kinds of soil will not make a good garden bed. NOT recommended for ground covered with palm leaves, vines, wire or long grass as it will clog the tines and will not till ground.

! WARNING If tines jam or stop (tines no longer rotate) pull unit back as it could release blockage. Otherwise switch off, if battery model, remove battery. Place machine upright with handles on ground (Fig.80). Remove obstruction.



FIG 80

Clutch: The Atom Tiller is equipped with a centrifugal clutch.

DO NOT run tiller at low speeds (or, if jammed) as clutch shoes will prematurely wear and cause damage, Fig. 81.

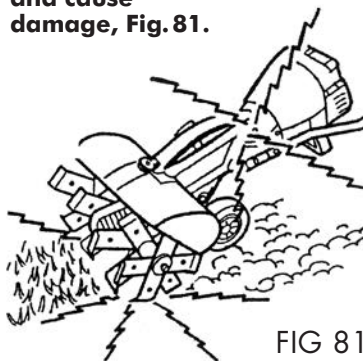
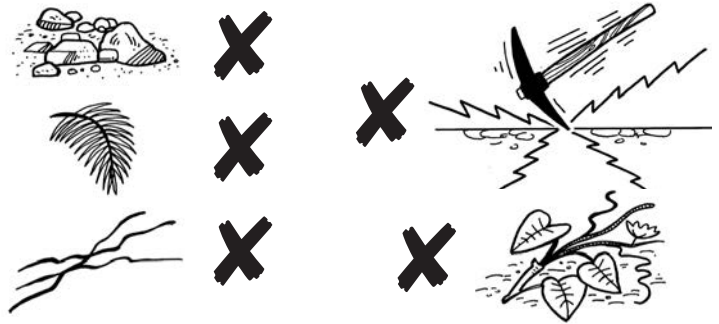
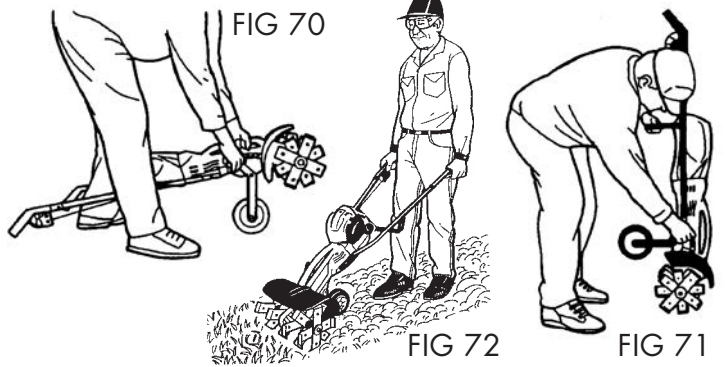

FIG 81



MULCHING

BEFORE

AFTER

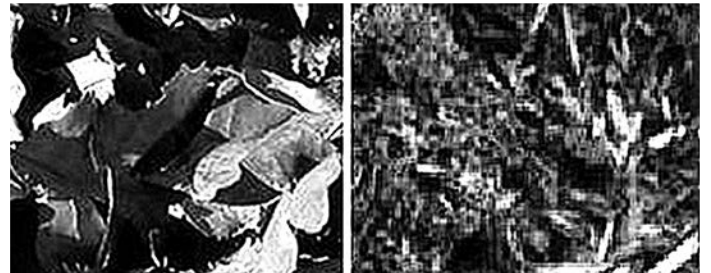

Using an Atom Tiller is a highly efficient method of creating a compost heap in the corner of your garden. This nutrient rich mulch and compost can be used to improve existing beds and stimulate rapid earth worm activity.

It only takes a few minutes to produce compost. Make a pile of leaves, lawn cuttings and other small leafy or vegetable matter, about 500mm high. Place some soil on top and spray with water. Use your Tiller to break it up into small pieces. Make the pile as big as you like.

Repeat a week later. Leave for another week and it is ready for use. You can add to the compost any time you wish.

! WARNING TO AVOID PERSONAL INJURY, NEVER CARRY THE TILLER WHILE ENGINE IS RUNNING.

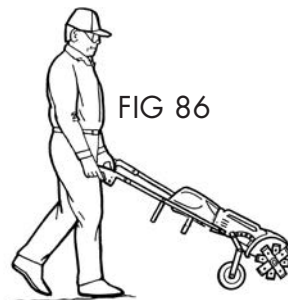

FIG 86

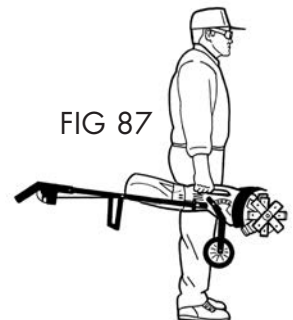

FIG 87

The Tiller can be easily moved as shown above. Prior to lifting or carrying, stop the motor Fig.87.

AFTER FINISHING WORK

Storing: Keep the unit in a dry place until you need it again.

OPERATING INSTRUCTIONS: AIRLIFT BLOWERS

AIRLIFT PETROL BLOWERS

! NOTE The Atom 4-Stroke blower achieves instant full power from start-up. As with all 2-Stroke blowers, the Atom 2-Stroke blowers may take several minutes of full speed running to achieve full power.

Start the motor (page 10, Fig.58) and allow to run to warm up.

To stop the motor, push combination stop lever/cruise control lever forward.

PETROL & BATTERY BLOWERS BLOWERS

To increase speed of blower, pull trigger throttle up. To lock in any speed, move cruise control lever rearwards when operating trigger throttle.

To release the "cruise control" push lever forward.

On full "cruise control" hold blower **at end of handle**, to allow nozzle to point at angle to ground without wrist twist. Shown in Fig.99A.

HOW TO USE YOUR ATOM BLOWER FOR THE QUICKEST AND BEST WAY TO CLEAN UP

1. Use blower holding rear of handle as shown Fig 99A (WITHOUT downward wrist twisting as has to be done for other brands) and with cruise control fully on. **AIRLIFT®** is active making blower up to 1 kg lighter to use **with either left or right hand**.
2. Because the Atom **AIRLIFT®** blower is so light at full throttle it can easily be held 30mm clear of operator pants **or in front of operator** (Fig. 99B). Regardless of position blower is always in comfortable smooth stable equilibrium.
3. Using the massive Atom **AIRLIFT®** air blast in this way speeds up the work to be done and saves on fuel. Atom petrol blowers work continuously and restart easily in extremely hot weather.

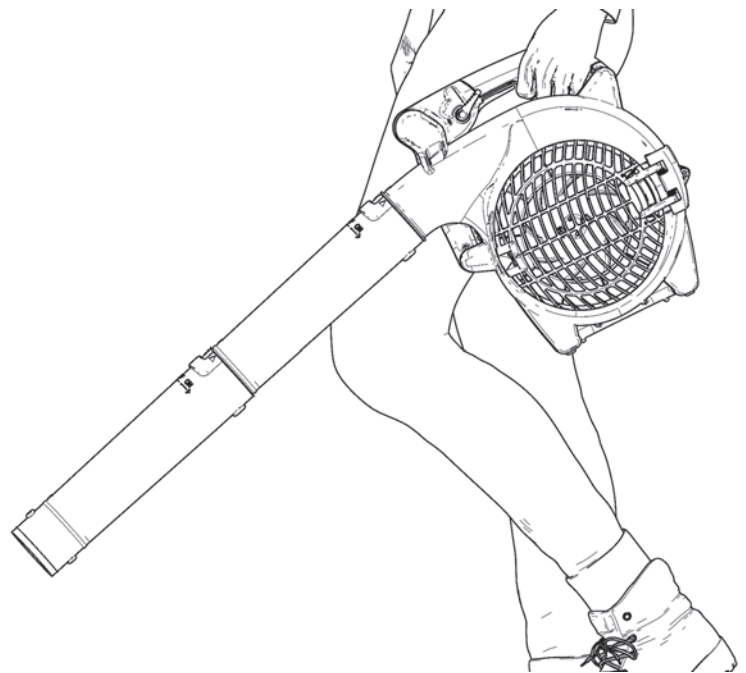

! NOTE Battery Blowers going on full power reduces run time.



FIG 99B

ATTACHMENTS (optional extras) fit all AIRLIFT Blowers

Vacuum with Shredder
Reduce leaf matter 12:1 for composting.

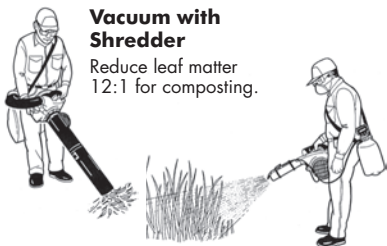

Spraying/ Misting
For quickly and easily spraying and misting vegetable gardens, fruit and ornamental trees, noxious weeds, etc.

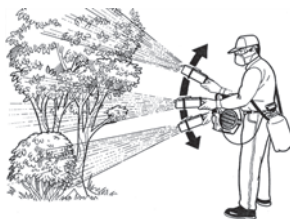

Roof Gutter Sliding Cleaner
Up to 3.5 metres above ground. **Very fast to use.**



Inspect the unit to ensure that it is complete. Select auger bit size to suit diameter of hole to be drilled. Insert auger bit into shaft with the flat on its shank pointing towards the grub screw. Tighten very firmly grub screw with the 6mm allen key provided. See Fig.73.

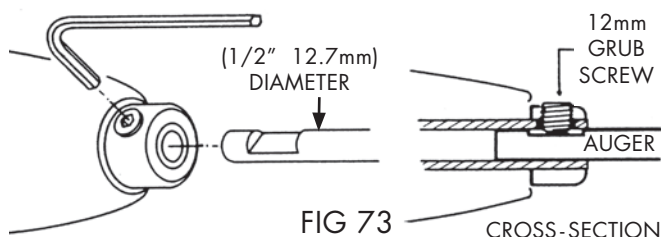

FIG 73

! WARNING As with any other power tool it is essential that you first make yourself familiar with all the safety precautions that have to be taken. Never take risks which could endanger yourself or others. You should strictly observe these simple rules:

DO NOT USE the Drill unit; unless you have proper balance, a firm and safe footing, a firm and steady grip on the clean and dry front handle and rear handle. Do not over-reach. If you do not have a firm grip and/or your feet are not securely placed in a firm position (eg. on slippery ground; in tree branches; on ladder, chair, makeshift platform; etc), injury can occur.

When using the Drill unit the front handle **must be used** and held firmly with your left hand, and **"CUPPED" RIGHT HAND UNDER REAR THROTTLE HANDLE**. (See Fig.60 on page 10). **If the engine stops while drilling do not restart with auger in hole as serious injury could occur.**

If drilling higher than your shoulder height above ground level, then you **must stand** only in a hydraulic bucket ("cherry picker"). Anything else, such as standing on ladders, tree branches, etc, is forbidden due to risk of injury. Fig. 74. Over-reaching is dangerous.

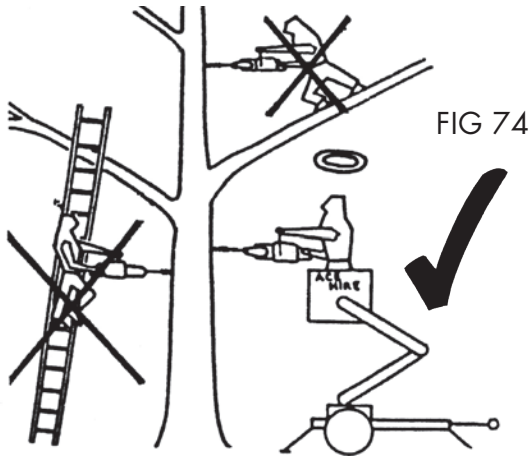

! WARNING Never touch an auger with your hand or any part of your body or clothes when the engine is running, even when the auger is not rotating. The auger continues to rotate for a short period after the throttle trigger is released until the automatic clutch disengages. The engine's idling speed must always be correctly adjusted, so that the auger does not rotate on idle.

! SAFETY WARNING Check 7 handle screws #1-#7 are tight as in Figs 36 and 38 on page 6.

REACTIVE FORCES, TWISTING ACTION

Reactive (twisting) forces with the power drill may occur at any time the auger is rotating. **Reactive forces can be dangerous!** In any drilling machine, the powerful rotational torque used to drill wood works against the operator. See Fig.75 and 76. If the rotating auger is suddenly stopped by contact with any binding object like a wood knot, split, nail or cross hole, the reactive forces twisting the drill unit may occur instantly.

! WARNING These reactive twisting forces could result in loss of control of the drill unit. An understanding of the causes of these reactive (twisting) forces will help you avoid loss of control. The greater the force of the kickback reaction, the more difficult it may become for the operator to control the drill reactive force.

DRILLING FIG 75

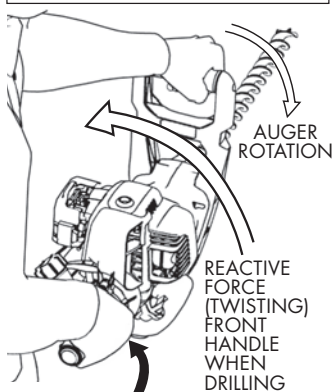

TWIST THROTTLE LEFT TO INCREASE ENGINE SPEED

REVERSING FIG 76

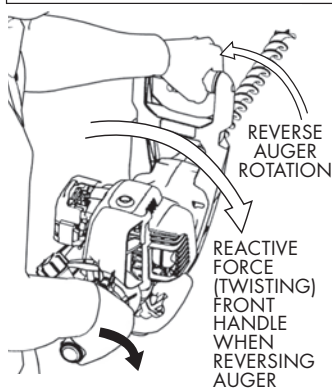

TWIST THROTTLE RIGHT TO DECREASE ENGINE SPEED

Start engine and allow to idle while locating the auger in position for drilling the hole. Push Engine Drill towards the wood and increase the power by rotating rear handle anti (counter) clockwise to drill the hole. For deep holes drill only 50 to 75mm (2-3") at a time and clear the auger frequently by pulling the drill back into reverse gear, thus preventing overloading of auger in the hole with wood chips.

! WARNING Whenever Drillmaster is put into reverse gear any re-active force DOES NOT activate safety throttle control to idle speed. Therefore, when reversing always be alert and have a firm grip on the unit.

To clear the hole or withdraw the auger, allow engine to slow down and pull attachment back towards you to engage reverse gear and then increase engine speed. This will unscrew the auger in an anticlockwise direction. The drill automatically changes back to clockwise rotation.

! NOTE The operator can stop or reduce the twisting of the Drill by firmly holding the Front handle with his left hand and twisting throttle control clockwise to the right with his right hand causing the engine speed to slow to idle thus stopping twisting of the drill and rotation of auger.

In an extreme situation when forward drilling and there is insufficient time to counteract the twisting force which will cause the drill to rotate suddenly to the left also will cause the rear hand held throttle to move to idle position thus stopping the rotation of the Drill unit. Pull unit carefully back into neutral increasing speed and pull back hard for Drill to engage reverse gear and the auger will un-screw out.

Recommence drilling and reversing to clear hole of wood chips and continue drilling.

! NOTE DRILLMASTER (including 4-Stroke Honda powered) can be used sideways (as shown in Fig.77), to reduce the handle reach when drilling at shoulder height. Any higher and you must use a hydraulic bucket as in Fig. 74.

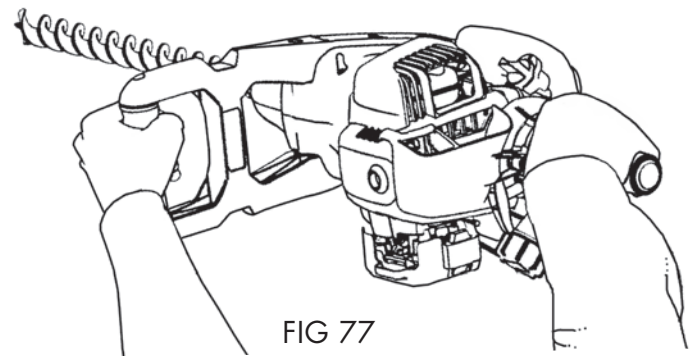

! NOTE WOOD AUGERS Atom Brand Wood Augers have double cutting front edges, better chip evacuation, excellent feed rate and easy sharpening. See page 21 for sizes and sharpening.

! SAFETY WARNING If Auger severely jams in timber, stop engine, disconnect Drill from auger and remove auger with a Stillsons wrench. If motor stops while drilling for any reason then disconnect drill from Auger and remove Auger with Stillsons. Rectify reason for stoppage eg. ran out of fuel.

TRANSPORTING THE DRILL

! WARNING Always stop the engine before putting a Drill unit down or carrying it. Carrying a drill unit by hand with the engine running is extremely dangerous. Accidental acceleration of the engine can cause the auger to rotate. Grip the front handle of the Drill when carrying, with the auger behind you. During operation, the engine muffler and the material around it reach extremely high temperatures. Avoid touching the hot muffler, you could receive serious burns. A worn, holes or damaged muffler could cause excessive heat to be blown, damage (or a fire).

Transporting: Properly secure your Drill unit to prevent turning over, fuel spillage and damage to the Drill unit. Keep drill unit clean at all times.

MAINTENANCE: EDGERS

BLADE REPLACEMENT

1. Use impact driver to undo blade nut. Otherwise clean area around grease/dust cover #62936 and pry off with screwdriver (Fig. 78) exposing 14mm hex head (for holding while unscrewing blade nut).
2. Through opening, place **14MM FULL 6 SIDED 6 pointed socket spanner** (do not use 12 sided 12 pointed socket spanner) over hex head, and use 18mm (or adjustable) spanner on blades nut. (Fig. 79).
3. Unscrew blade nut counter (anti) clockwise (normal right hand thread).

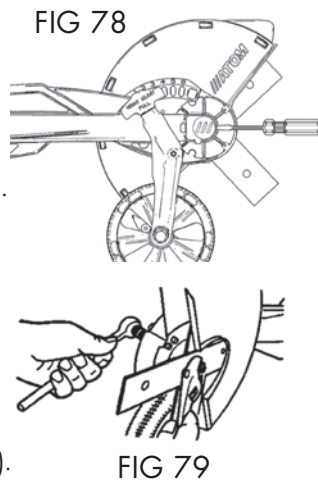

USE ONLY ATOM 2 PIECE CROSS BLADES

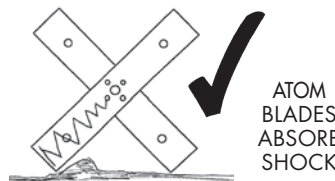

DO NOT USE any one piece solid blade

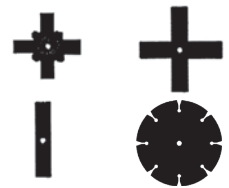

Beware of blades advertised as Atom Blades, or "superseded by", "replaces", etc being "passed off" as Atom Blades. This is a trademark infringement, and are false and misleading statements.

All model Atom Edger Blades are supplied in a sealed white plastic pack branded ATOM with clear instructions on "How to fit" and promoting other Atom products on the reverse side. Any other packaging not as above, are not genuine Atom product, and, if used on Atom Edgers, will be detrimental and void any warranty.

4. Remove nut anti-clockwise, one large washer and two blades (Fig. 80). Before installing blade and washers, clean off all grit and grease. Re-assemble these parts clean and dry. Fit large washer, new blades #43105 with spiggots of one blade interlocking with holes on opposite blade, large washer and nut. Tighten nut to 15-20ft.lbs. (20-27Nm) or hand tight with 8" (200mm) or longer spanner.

FIG 80 FITTING INSTRUCTIONS

FIT BLADES AT RIGHT ANGLES
2 SPIGOTS ON EACH BLADE
FIT INTO HOLES OF OTHER BLADE

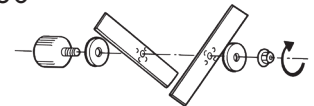

! NOTE

Always use two blades as shown above. Never use a single blade or other thicker blades as you will damage the unit.

! WARNING USE OF NON ATOM EDGER BLADES IS DETRIMENTAL AND VOIDS ANY WARRANTY.

These types of blades should NOT be used on any model Atom Lawn Edger due to heavy mass weight, thickness of blade/out of balance, warping creating vibration and overloading of the gear mechanism of Atom Edgers.

These non-genuine blades do not absorb shock, which is taken by the Edger gear system causing subsequent damage. A safety issue may arise as solid one piece blades are heavier and take longer to stop spinning when motor is turned off or reduced to idle, due to heavier weight and flywheel effect.

Atom twin Cross Blades absorb shock and excessive loading and have been proven over 15 years as the only blades compatible with the Edger gear system to guarantee long life.

MAINTENANCE: TILLERS

! NOTE LUBRICATION OF WORM GEARS

Every 5 hours top up with grease to gear box.

Remove filling screw and inject grease through hole. Grease squirts back out of filler hole when full.

Available in squeeze bottle. Part No. 43227.

DO NOT USE SYNTHETIC BASED GREASE

Use mineral grease (usually lithium based).

WARRANTY VOID IF LACK OF GREASE

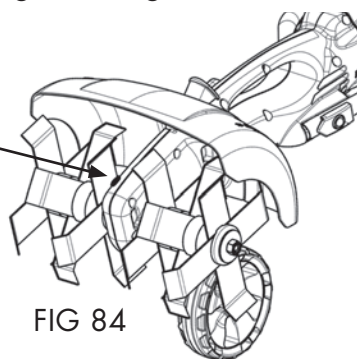

! WARNING

If tines jam or stop (tines no longer rotate) pull unit back as it could release blockage. Otherwise switch off. If battery model, remove battery. Place machine upright with handles on ground (Fig.80). Remove obstruction.

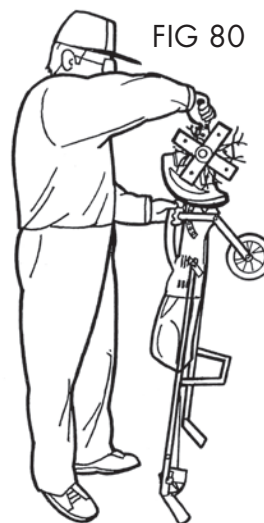

Clutch: The Atom Tiller is equipped with a centrifugal clutch.

DO NOT run tiller at low speeds (or, if jammed) as clutch shoes will prematurely wear and cause damage, Fig.81.

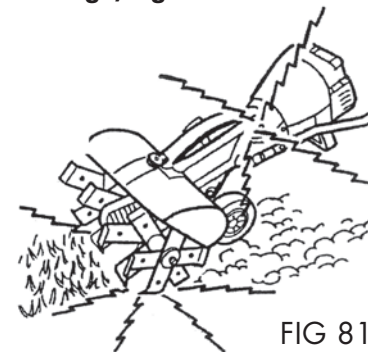

! NOTE

Keep inside of tiller guard clean, especially in wet conditions. A clogged guard can slow down or stop tine rotation and may cause damage to automatic safety clutch. Remove any tangled grass or wires around tines.

Clean tines of grass, rocks and sticks, always **use gloves** as tines are sharp and self sharpening. You could cut yourself. Remove tine cover as follows: Lift knob Fig.82 twist and slide cover forward Fig.83. If jammed, cover can be tapped off with a soft hammer.

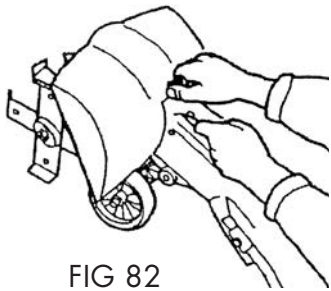

FIG 82

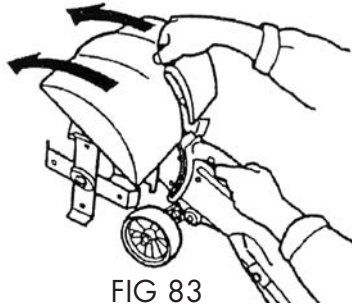

FIG 83

LOOSE TINES

Check that all tines are in correct position and are tight together, no gaps or foreign material between them. Tighten nut clockwise on LH side of unit and anti clockwise on RH side (Fig.85) as shown on top of tine cover.

! NOTE

Tines are self tightening. Excessive tension is not required.

RIGHT HAND SIDE
(Standing behind tine cover)

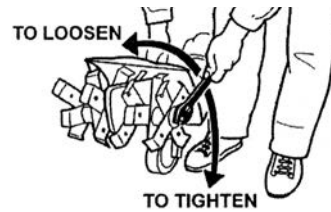

LEFT HAND SIDE
(Standing behind tine cover)

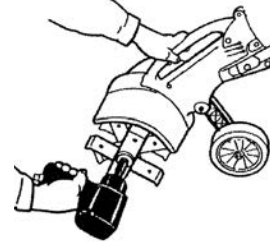
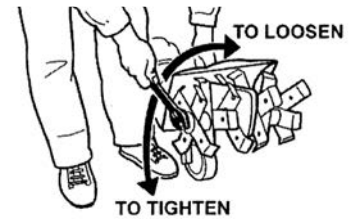
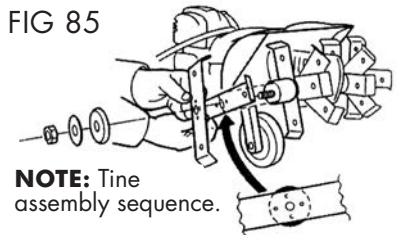

FIG 85



NOTE: Tine assembly sequence.

Levelling uneven ground: The tiller if used carefully can level uneven ground for a good garden bed. Use your arms to work the tiller forwards and backwards.

After levelling pre-work all surfaces to prepare the new flat bed. Use a rake to smooth out and tidy up.

The tiller can be transported by pushing it on its wheel.

Very hard ground, clay or rocky conditions: The Atom rotary tiller is NOT DESIGNED for very hard ground, hard or rocky conditions. These kinds of soil will not make a good garden bed. **WARNING:** When using air tools to remove nut, do not overtighten when refitting.

MAINTENANCE: PETROL AIRLIFT BLOWERS

1. Check oil level (4-Stroke) with dip stick #1. Also see page 10 Fig.50B.
2. Check regularly the air filter element as per instructions on page 19 #2.
3. Adjust idle speed screw for engine to always have fast idle speed (for easier starting).
4. Check all screws are tight on RH side of blower.
5. The internal three handle mounting springs can be checked with Torx20 screwdriver inserted into 3 handle recess holes #4.
6. Discard carefully any old fuel in tank if unit has not been used for three months or more #5. Refuel with fresh fuel.
 - For 4-Stroke engine use regular Petrol (no oil) and change sump oil every 50 hours and regularly check oil level.
 - For 2-Stroke engine use regular Petrol with 50 to 1 oil. See page 10.
7. Replace any broken or worn parts
8. Cruise control tension screw adjustment

If you have other service issues see pages 18 to 20 and consult your authorised Atom Dealer.

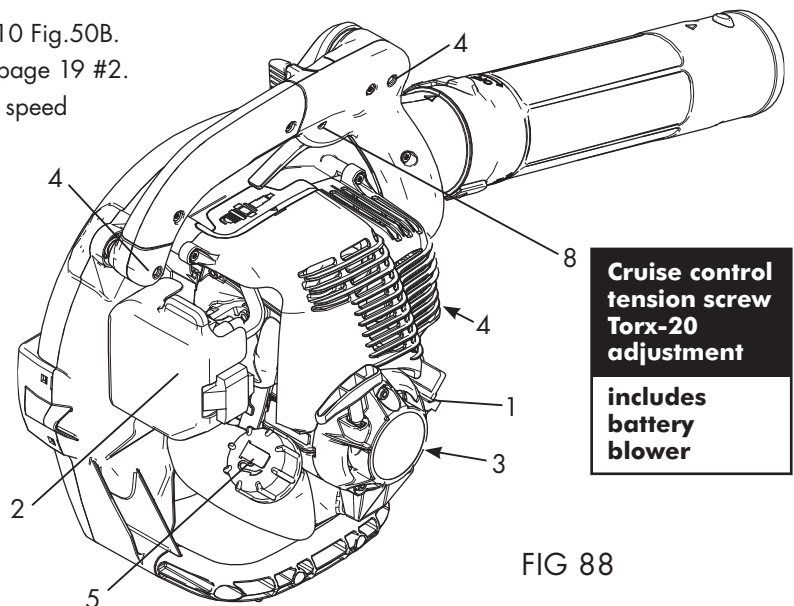

Cruise control tension screw Torx-20 adjustment
includes battery blower

FIG 88

MAINTENANCE: DRILLMASTER ENGINE DRILLS

1. Depending on use, check all Torx25 screws around gear box (A), engine mount (B), Handles (C). Check various screws around recoil starter (D). Also check Torx20 screw (E) that locks throttle cable clamp.
2. Check after starting and warm up engine that idle speed does not turn auger. If adjustment required see page 19.
3. Check that ignition OFF SWITCH (E) turns motor off.
4. Ensure grub screw is tight on auger flat to prevent auger from loosening.
5. Add grease every 50 hours from grease bottle. Part No.43227. Minimum three squeezes. Fig. 90.

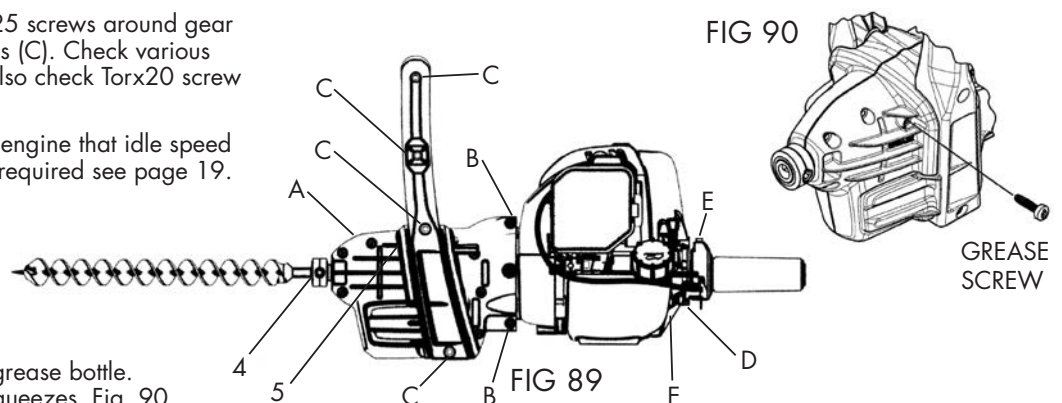

FIG 90

FIG 89

GREASE SCREW

MAINTENANCE: PETROL ENGINE AIR FILTERS

AIR FILTER MAINTENANCE

The air filter is one of the most important areas to maintain. If it is not maintained, engine will be damaged, also you will void the warranty. Before cleaning make sure the unit is turned off.

! NOTE Clean and re-oil the air filter every 10 hours of use. More frequently in dusty conditions. Eg. every 5 hours.

1. If filter is torn or very dirty, replace.
2. Wash the filter in detergent and water (Fig.92.) Rinse the filter thoroughly and allow to dry.
3. Apply enough clean engine oil or 2-Stroke oil to saturate the filter when squeezed. Squeeze the filter to spread the oil and to remove excess oil.

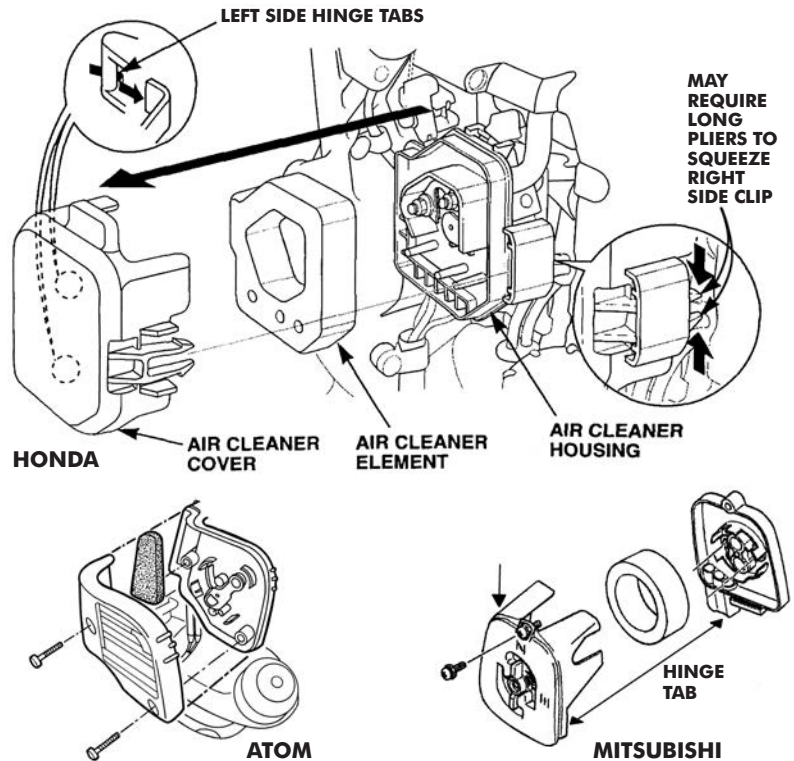
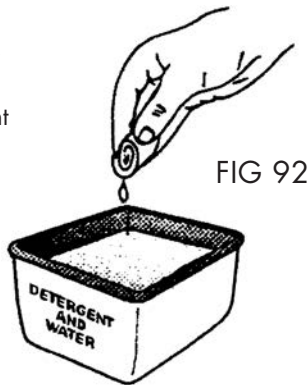

! NOTE If the unit is operated with dry or dirty filter or without the air filter and/or carburettor air filter cover, you will void the warranty.

ADJUSTING IDLE SPEED

The idling screw adjustment is accessible without removing the air filter cover. See Fig.94. To increase engine idle speed, turn IDLE SCREW (2) clockwise. To decrease engine speed, turn IDLE SCREW counter clockwise (anti-clockwise). Throttle trigger to be in idle position.

Cable adjustment can also be used to adjust idle.

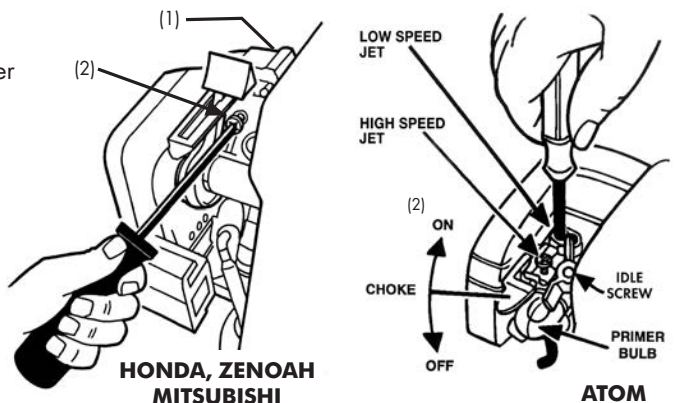
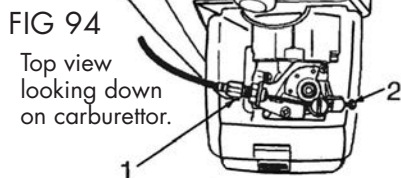

EDGERS, ENGINE DRILLS & TILLERS – Blades or Auger MUST NOT TURN AT ENGINE IDLE SPEED.

BLOWERS – ALWAYS have FAST idle speed for easier starting.

FUEL FILTER MAINTENANCE

Hook out fuel filter with piece of bent wire. Blow clean with compressed air or replace.

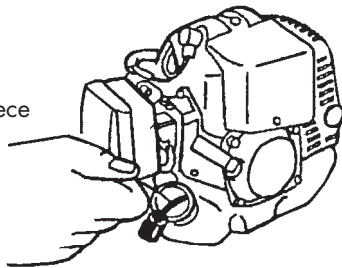

If motor doesn't deliver full speed, check fuel flow with fuel line disconnected from carburettor and shake engine for build-up pressure for fuel to rapidly run out.

ATOM ENGINES JET ADJUSTMENT

26FCS, 26FC-3, 26FC-4, 26FC-5 and 26HPE

- High speed approximately 1 1/4 turns
- Low speed approximately 1 1/4 turns

CHECKING THE SPARK PLUG

If engine is low on power, difficult to start or runs poorly at idling speed, check the spark plug.

- Allow engine to cool down. Remove spark plug.
- Clean dirty spark plug or replace with new spark plug.
- Check electrode gap 0.5mm (0.020")
- Rectify faults which have caused fouling of spark plug.

Possible faults include:

- Dirty air filter or fuel filter

- Unfavourable running conditions (eg. operating at part load)
- Too much oil or wrong type of oil in fuel tank in 2-Stroke engine.

Do not clean the spark plug in an abrasive grit spark plug cleaner, as expensive damage to the engine could occur through loose grit damaging chrome in cylinder bore.

Fit a new spark plug after approximately 50 operating hours or earlier if electrodes are badly eroded.

Check recommended spark plug is type or equivalent and specified electrode gap for each engine make.

MAINTENANCE: PETROL ENGINES & ALL GEAR BOXES

REGULAR SERVICE PERIOD

Perform at every indicated month or operating hour interval, whichever comes first.

ITEM		Each Use	Every month or 5 hrs	Every 6 months or 50 hrs	Every year or 50 hrs	Renew when unserviceable	Every 2 years or 300 hrs	Refer to page
Engine Oil (4-Stroke)	Check level	<input type="radio"/>						9
	Change		<input type="radio"/>					9
AIR CLEANER Regularly service. Very important to prolong engine life.	Check	<input type="radio"/>						18
	Clean & oil sponge filter element		<input type="radio"/> (1)					18
	Clean paper filter element		<input type="radio"/> (1)					
	Replace paper filter element					<input type="radio"/>		
Engine idle speed check adjust		<input type="radio"/>						19
Professional edger gear box	Add grease			<input type="radio"/>				9
Tiller gear box	Add grease	<input type="radio"/>	<input type="radio"/>					16
Engine drill gear box	Add grease			<input type="radio"/>				17
Fuel filter	Check and/or replace				<input type="radio"/> (2)			18
Fuel tubes and grommit	Check	Every 2 years (Replace if necessary) (2)						
Oil tube (4-Stroke)	Check	Every 2 years (Replace if necessary) (2)						
Spark Arrestor					<input type="radio"/>			
Engine cooling fins	Check		<input type="radio"/>					
Nuts, bolts, fasteners (Retighten if necessary)	Check Visual inspection	<input type="radio"/>	<input type="radio"/>					
Carburettor nuts, bolts, fixtures (Retighten if necessary)					<input type="radio"/>		<input type="radio"/>	
Spark plug	Check-adjust				<input type="radio"/>			18
	Replace						<input type="radio"/>	18 & 24
Carburettor gaskets or "O" rings. Renew as required if hard starting or lack of idle control						<input type="radio"/> (2)	<input type="radio"/> (2)	
Combustion chamber, muffler	Clean	After every 300 hrs				<input type="radio"/> (2)		
Valve clearance (4-Stroke)	Check-adjust						<input type="radio"/>	

- NOTE: (1) Service more frequently (eg every 5 hours) when used in dusty areas. Replace if damaged or unserviceable.
 (2) These items should be serviced by your servicing dealer, unless you have the proper tools and are mechanically proficient.
 (3) Log hours of operation to determine proper maintenance intervals.
 (4) Some parts of the power tool are subject to normal wear and tear even during regular operation in accordance with instructions, and depending on the type and duration of use have to be replaced in good time. Among these parts are air filters, fuel filters, fuel lines and grommets, rewind starter parts, manifold o-ring (Honda). These are not covered by warranty.

IMPORTANT STORAGE: If storing unit for three months or more drain fuel from tank, restart motor to use fuel in carburettor. Store in a safe and dry place.

BATTERY & BRUSHLESS MOTOR INFORMATION

All batteries produce high current when fully charged but after some immediate use and while discharging will produce slightly less power.

Both the battery, and motor, have separate solid state management systems to prevent overloading or burn out. If for example the edger or tine blades are suddenly jammed, the management systems will switch off. Therefore release trigger throttle completely, then after pressing interlock, pull trigger to recommence edging or tilling. Similarly for trimmer.

The blower in the first few minutes produces massive power, the management systems may switch unit off. If motor stops because of overload, release trigger completely for a few seconds before pulling trigger again, using slightly less throttle for a few minutes.

In all applications with very high ambient temperatures (35^o+) management systems may substantially reduce power output or cut out until battery cools.

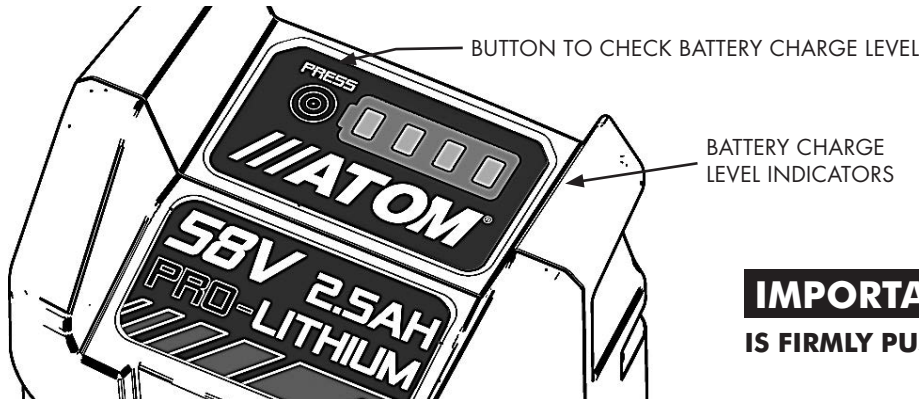

When machine not in use remove battery. Battery may discharge if unused for period of time. Best to top up charge before using for maximum run time.

IMPORTANT WHEN INSERTING BATTERY INTO MACHINE, ENSURE IT IS FIRMLY PUSHED DOWN.

TROUBLESHOOTING: EDGERS – TILLERS – BLOWERS

PROBLEM	CAUSE	ACTION
1. Blades do not turn when operating	Loose blade nut or incorrect assembly.	Tighten blade nut (or also add washer under nut).
	Blade cover filled with dirt/grass/mud.	Clean.
	Blade stops under load when blade depth is too deep.	Cut less depth. Set wheel arm on 3 or 4.
	Clutch slipping can damage clutch and housing.	Cut less depth or clean. Set wheel arm on 3 or 4.
2. Motor lacks power or blade stops rotating	Cutting too deep.	Decrease cutting depth and see (1) above, engine always to run at full throttle
3. Throttle trigger will not switch motor on battery powered machine – Edger Blower Tiller Trimmer	Battery flat.	Recharge
	Throttle cable may need re-adjusting.	Adjust throttle cable by loosening 2 trigger cover screws and pulling throttle cable about 2mm out. Retighten screws.
	Motor switches on then stops.	Battery not pushed down into machine or battery needs recharging.
	Motor switch or motor not activating.	Battery/Motor hot – allow to cool.
	Motor damaged.	Take to service dealer.
4. Heavy vibration	Wrong blade fitted.	Only use ORIGINAL Atom blade set #43105
	Worn clutch or clutch drum or damaged drive.	Take to service dealer.
5. Petrol engine will not run or runs and stops	Ignition switch is OFF	Ignition switch to be in run position.
	Choke ON	Push choke off.
	Partially empty fuel tank	Fill tank.
	Primer bulb not pushed enough times	Press primer bulb fully and slowly 10 times.
	Engine is flooded	Use correct start procedures.
	Dirty or blocked fuel or air filter	Clean or replace fuel or air filter.
6. Carburettor:	If adjustable jets fitted	Open jets slightly
	If not adjustable	Clean carburettor
	Dirt in carburettor or old fuel	Clean.
7. Edger blades or Tiller cutting tines do not turn when operating	Edger or tine cover filled with dirt, grass, sticks and rocks	Clean.
	Clutch slipping	Less depth. Check edger blades are spinning or tiller tines rotating
	Loose blade or tine nut, washers missing	Check for missing washers. Tighten edger blades or tine nuts both sides.
	Petrol engine choke partly on	Slide choke off.
9. Blowers petrol	Hard to start	Increase engine idling speed.
8. Blower 855 with red manifold	Hard to start (if well used)	Replace manifold o-ring with spring seal kit P/N 65186.

TROUBLESHOOTING: PETROL AIRLIFT BLOWERS

There is very little to go wrong with your Atom Airlift Blower. Follow all instructions including pages 18 and 19. These include:

1. **Clean and oil air filter regularly. Extremely important in dusty conditions.**
2. Use SAE 10-30W automotive oil in 4-Stroke engines (non-synthetic).
3. Use good quality 2-Stroke 50/1 oil as 50:1 fuel mix in 2-Stroke engines ie. 20ml oil to 1 litre petrol or 80ml oil to 4 litres petrol.
4. If storing unit for 3 months or more, drain fuel from tank, restart motor to use residual fuel in carburettor.
5. Follow regular maintenance chart. Page 18.
6. Starting and idling are covered on Page 19. If well used Honda engine is harder to start, check o-ring on manifold for o-ring replacement.
7. **Starting difficulties could occur when the idle speed is not fast. After much use idle speed can drop back. Keep fast idle speed for easy starting.**
8. If Atom engine powered blower does not achieve full RPM, check that choke is full off and that carby is full on when throttle trigger is pulled fully up. If necessary adjust throttle cable for full throttle. Otherwise adjust carby jet.
9. If Honda engine powered blower does not achieve full power, check that choke is fully open and that carby is full on when throttle trigger is pulled fully up. Otherwise adjust throttle cable.

TROUBLESHOOTING: DRILLMASTER ENGINE DRILLS

PROBLEM	CAUSE	ACTION
1. Auger will not turn at all	1. Blunt auger, must be sharp especially for large holes over 19mm (3/4"). Always when drilling, drill 50mm then reverse out to clean shavings from hole.	Sharpen – see instructions below.
	2. Not enough power. Check carby adjustment tune engine. Blunt auger or worn out, not cleaning hole of wood chips by reversing and cleaning holes every 50mm or less. Incorrect side clearance on auger.	Sharpen auger or replace. Only use Atom augers (Other brand augers not made for Australian wood).
2. Drill unit appears not to reverse auger to clean out hole of shavings.	1. Type of timber soft so auger does not grip auger to allow unit to reverse.	Small diameters to 13mm (5/8") may cause this problem. Drill and reverse every 50mm.
	2. Reverses and unjams very quickly. Very hard to see instant automatic reverse changing to forward drilling. (R.H. rotation)	
3. Safety issues. Not using equipment. Read manual and ensure you understand all.	Not reading manual.	Do not take risks when using equipment. Read manual thoroughly and ensure you understand. Before each work period check Drillmaster drill and ensure all screws are tight. Ensure it is working correctly. The auger must not turn when petrol engine idling and fuel tank is filled.

SHARPENING WOOD AUGERS

The best hardwood auger is the Atom chisel tip auger with 4 cutting edges (ie 2 longitudinal cutting edges and 2 radial cutting edges).

SHARPENING ATOM AUGERS

Use a small half round file or 3/16 Round file. **Carefully file inside the shaped curve of the cutting edges.**

If correctly sharpened, the cutting edges will be as sharp as saw chain teeth. Once they become dull they should be resharpened as described.

Never file the outside edges of the auger cutters.

Atom Hard Chisel Tip Augers are the perfect partner for Atom Drillmaster drills.

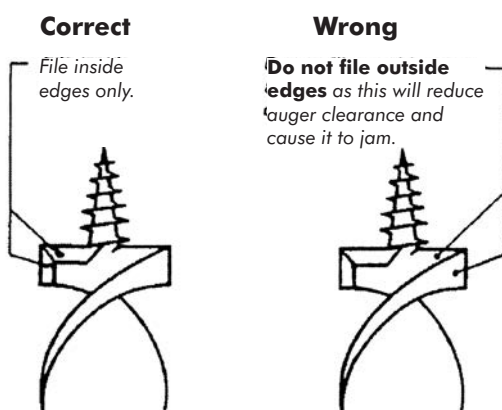

Atom augers are available in the following diameters and lengths:

PART NUMBER	DESCRIPTION
30010	3/8" (10mm) diameter x 12" (300mm) long
30011	7/16" (11mm) diameter x 12" (300mm) long
30013	1/2" (13mm) diameter x 14" (360mm) long
30014	9/16" (14mm) diameter x 14" (360mm) long
30016	5/8" (16mm) diameter x 14" (360mm) long
30018	11/16" (18mm) diameter x 14" (360mm) long
30019	3/4" (19mm) diameter x 14" (360mm) long
30022	7/8" (22mm) diameter x 14" (360mm) long
30025	1" (25mm) diameter x 14" (360mm) long
30028	1 1/8" (28mm) diameter x 14" (360mm) long
30032	1 1/4" (32mm) diameter x 14" (360mm) long
Extra Long Augers	
30116	5/8" (16mm) diameter x 30" (760mm) long
30119	3/4" (19mm) diameter x 30" (760mm) long
30122	7/8" (22mm) diameter x 30" (760mm) long
30125	1" (25mm) diameter x 30" (760mm) long

PRODUCT WARRANTY INFORMATION

Product Warranty - Consumer Rights, Warranty Information and Warranty Terms

The buyer should be aware that in relation to goods which are of a kind ordinarily acquired for personal, domestic or household use or consumption, certain provisions under the Australian Consumer Law, and the Consumer Guarantees Act, 1993 (NZ) apply. The terms set out below do not exclude rights and remedies implied by a statute which are non-excludable, and which may be more extensive than those provided by this warranty.

Atom Warranty Service

Warranty Service is available at any Atom Authorised Service Dealer. These dealers are equipped to provide expert service. Please see below as to how to claim under warranty. There is NO warranty if product is not delivered pre-serviced and assembled by an Atom dealer.

Atom Warranty

Our goods come with guarantees that cannot be excluded under the Australian Consumer Law. You are entitled to a replacement or refund for a major failure and you are also entitled to have the goods repaired if the goods fail to be acceptable quality and the failure does not amount to a major failure. The Atom Warranty is additional to the conditions and warranties which are mandatorily implied by the laws and regulations of the individual States and Territories of Australia and the Australian Consumer Law; the Consumer Guarantees Act in New Zealand; and any non-excludable laws.

Limitations of Warranty

Warranty applies to the original purchaser only. Proof of purchase date must be provided with the original sales docket prior to any warranty work. This is also proof that the unit is not a stolen unit.

USE OF NON-GENUINE ATOM PARTS VOIDS WARRANTY.

NO WARRANTY APPLIES IF GOODS ARE NOT ASSEMBLED & PRESERVICED BY A SERVICING DEALER, WHETHER PURCHASED ONLINE OR PURCHASED DIRECTLY FROM DEALER. PURCHASES IN A BOX ARE NOT WARRANTED.

ATOM LAWN EDGERS (Petrol)

DOMESTIC	MODEL NO	WARRANTY PERIOD
Non-current models	435,441,454,480	2 years - first year parts and labour. Second year parts only.
Current models	438,458,481	4 years – first year parts and labour, years 2-4 parts only.
<i>Note: Professional or commercial use of domestic models voids warranty.</i>		
PROFESSIONAL LAWN EDGERS (Petrol)		
Professional use	561,562,581,582,585,586	1 year - first 6 months parts and labour. Second 6 months parts only.
Domestic use	561,562,581,582,585,586	3 years – parts and labour.

ATOM LEAF BLOWERS (Petrol)

Deluxe Economy	838	Domestic use 3 years parts and labour.
Professional	855,858	Professional use 1 year parts and labour. Domestic use 3 years parts and labour.

ATOM DRILLMASTER ENGINE DRILLS (Petrol)

Economy and Intermediate	938, 956, 958	1 year professional use—first 6 months parts & labour. Second 6 months parts only. 2 years non-professional use - first year parts and labour. Second year parts only.
Professional & Super Pro	960,980,985	1 year - first 6 months parts and labour. Second 6 months parts only. 2 years non-professional use - first year parts and labour. Second year parts only.

ATOM TILLERS

Domestic use	738,758,756	3 years engine – 2 years parts – 1 year labour.
Used Commercially		1 year - first 6 months parts and labour. Second 6 months parts only.

ATOM BATTERY POWERED PRODUCTS (including skins)

Lawn Edger Domestic	315	5 years motor only. 4 years – (other than motor & battery) first year parts & labour, years 2-4 parts only. Professional or commercial use voids warranty.
Line Trimmer Domestic	615	
Leaf Blower Domestic	815	
Tiller Domestic	715	5 years motor only 4 years – (other than motor & battery) first year parts & labour, years 2-4 parts only. 1 year – commercial use first 6 months parts & labour. Second 6 months parts only.
58V Batteries	58V-2.5AH 58V-5AH	2 years domestic use – 6 months commercial use.
58V Charger	58V-C	2 years domestic use – 6 months commercial use.

ATOM CHISEL TIP WOOD AUGERS	All sizes 3 months	Augers guaranteed for breakage according to correct use. No warranty if augers used on hydraulic or heavy-duty electric drilling units.
------------------------------------	-----------------------	---

Under our Warranty the Atom product is warranted from the date of original purchase for the period as specified above against mechanical defects and faulty workmanship or material, which covers the replacement with factory assembled parts, parts repair or replacement of parts which fail due to a fault in manufacture.

Where applicable defective parts will be replaced or serviced by an Authorised Service Dealer without charge to the customer for labour or materials. This is subject to the condition that any repairs or adjustments required due to wear and tear or normal use. or by failure to

LAWN EDGER WARRANTY

Does not cover excessive overheating of clutch because operator neglected OPERATIONAL INSTRUCTION **and did not have blades spinning rapidly with motor speed at full throttle** and/or blades were digging in deeper than 10mm to 15mm into soil due to incorrect wheel height adjustment **thus causing blades not to spin rapidly causing clutch to continuously slip and overheat**. Blades on lawn edgers are not covered by the warranty.

GARDEN TILLER WARRANTY

Does not cover gear box damage or lack of adding grease every 5 hours as described in the operator manual.

ALL ATOM POWERED EQUIPMENT

- Use of parts by the buyer/owner other than genuine Atom spare parts (eg edger blades) and problems with the machine caused by the use of any other non-genuine parts, cancels the Warranty.
- Altering the product in any way cancels the Warranty.
- Any Atom gasoline product run with incorrect fuel, oil or oil level, is not covered by the Warranty.
- Failure to properly service cooling or air filtration systems cancels the Warranty.
- Failure to follow the instruction manual, instructions tags or instruction labels attached to the product, cancels the Warranty.
- Damage from an accident; misuse, neglect, dropping the unit or dropping anything on the unit, is not covered by the Warranty.
- Blades, filters and spark plugs are not covered by Warranty.
- Fair wear and tear and normal wear are not covered by the Warranty. Engines, like all mechanical devices, need periodic parts service and replacement to perform well. Warranty will not cover repair when normal use has exhausted the life of a part or an engine or machine. Warranty will not apply if the engine damage occurred because of misuse, lack of routine maintenance, shipping, handling, warehousing or improper installation. Similarly, warranty is void if the serial number of the engine or product has been removed or by using contaminated lubricating oil, or an incorrect grade of lubricating oil. For four stroke engines, check oil and refill when necessary, and change at recommended intervals. Two stroke engines must use the recommended fuel/oil ratio as prescribed in the manual that is supplied with the product. Spillage of fuel over engine parts creating blocked air filters is not considered warranty.
- Repair or adjustment of associated parts or assemblies such as throttle cables and switches are not covered by the Warranty.
- Damage or wear to parts caused by dirt, which entered the engine because of improper air cleaner maintenance, reassembly, or use of a non-original air cleaner element or cartridge are not covered by the Warranty. At recommended intervals, clean and/or replace the filter as stated in the Operator's Manual.
- The warranty also does not extend to repairs required because of:
 - a) Leaking carburetors, clogged fuel pipes, sticking valves, or other damage, caused by using contaminated and/or stale fuel/oil.
 - b) Parts which are scored or broken because an engine was operated with insufficient lubrication or other abuse in operation.
 - c) Requirement for a routine tune-up or adjustment of the engine.
 - d) Engine or engine component failure, ie, combustion chamber, valves, valve seats, valve guides, caused by the use of inferior gasolines, wrong oils in 4 stroke engines or incorrect gasolines and oils used in two stroke mixtures.
 - e) Service parts not replaced at the appropriate time according to the maintenance schedule.

Nothing in these terms shall exclude, restrict or modify any term, condition, warranty or liability implied into this contract by statute, where to do so would be unlawful or would render any provision of this contract void. Subject to that, all warranties implied by statute in respect of the goods are hereby expressly negated and the manufacturer's liability for the goods is limited to any warranties issued in writing by the manufacturer and the manufacturer is excluded from any liability whether under this contract or otherwise to the buyer or any third party for any loss, injury, cost or damage (direct, indirect, special, consequential, or otherwise), incurred or suffered by reason of the goods, their use, their design or any failure to deliver or delay in delivering them. Where it is legal to do so, any remaining liability implied by statute or resulting from breach of any term, condition or warranty implied by statute is limited to, at the manufacturer's sole option:

- The repair of the goods.
- The payment of the cost of replacing the goods.
- The payment of having the cost of the goods repaired.
- Or the replacement of the goods.

In particular, your rights and remedies under the Australian Consumer Law (Aust) and the Consumer Guarantees Act (NZ) are not excluded.

How to Claim Warranty

- The warranty period begins on the date of purchase by the customer and continues for the period of time stated in the warranty table on the previous page. Domestic/consumer use means for personal, domestic residential household use. Commercial or professional use means all other uses including but not limited to; use for income producing, or commercial (eg home units) etc, or rental, or any government or council purposes.
- Warranty service is available only through Atom Authorised Service Dealers. Locate your nearest Authorised Service Dealer in our dealer locator on www.atomindustries.com.au or by calling (02) 9810 0194 or freecall 1800 225 450. In NZ phone freecall 0800 174 753.
- The Customer is required to transport the Atom product to and from the Authorised Service Dealer at the expense of the Customer.
- The Customer must provide proof of purchase date by producing a sales docket.
- Before dealer commences repair they will contact Atom by phone for any genuine warranty claim. Atom will despatch parts, whether factory assembled modules or individual parts, as per warranty period and conditions.

LIMITATION OF REMEDY AND DAMAGES

Atom Industries liability under this warranty or any implied warranty that may exist is limited to repair of the defect in workmanship and repair or replacement of any defective part. Atom Industries will not be liable for incidental, special or consequential damages (including loss of profits).

ENGINES & SPECIFICATIONS

POWERED BY:	ATOM 26FC series + HPE	HONDA GX25	HONDA GX35	ZENOAH 26CC	mitsubishi TLE33	mitsubishi TLE48
Engine Type	2-Stroke (std + HPE)	4-Stroke	4-Stroke	2-Stroke	2-Stroke	2-Stroke
Engine Displacement	26cc	25cc	35cc	26cc	33cc	48cc
Engine Fuel	Petrol-oil mix 50:1	Petrol only	Petrol only	Petrol-oil mix 50:1	Petrol-oil mix 50:1	Petrol-oil mix 50:1
Engine Spark Plug	RCJ6Y	CMR5H	CMR5H	BPMR7A	BPMR8Y	BPMR8Y
	Champion	NGK	NGK	NGK	NGK	NGK

SERVICE & WEBSITE

SERVICE

Visit any of our nationwide Atom Service Dealers who will assist you with maintenance of Atom products. All dealers have immediate contact with our Head Office and a quick response is made. We and our dealers are dedicated to giving our customers good, old-fashioned and reliable service.

WEBSITE

Visit atomindustries.com for all aspects of Atom products. To see comprehensive lists of product parts, including explosions and parts lists. Click on Manuals tab and select product type.

atomindustries.com

© COPYRIGHT

This manual and part numbers are copyright. All rights reserved. This document is subject to conditions prescribed under the Copyright Act. No part of it may in any form or by any means (electronic, mechanical, photocopying, micro copying, scanning, recording or otherwise) be reproduced, stored in a retrieval system or transmitted or otherwise including reference to this copyright as a means of referring competitor products fitting to Atom products.

Atom products, including developments of **AIRLIFT®** and **BLOWMASTER®** blowers, blower anti-vibration handle system, **SMARTFAN®** impellers, and **DRILLMASTER®** engine powered drills with automatic reverse gear and rotary throttle control, are extensively protected by many Patents Pending, Patents, Registered Designs, and Registered Shapes and many Trade Marks including Atom Trade Mark 1,463,4000.

Additionally, US Patent No. 8,210,272-B2 tiller construction also covers and protects Atom Lawn Edger construction.

Registration No. 1470990 is a REGISTERED SHAPE of the Atom Lawn Edger consisting of three dimensional shape of lawn edgers having a ground engaging wheel supporting a motor or engine and a pair of handles in a wheelbarrow-like configuration.

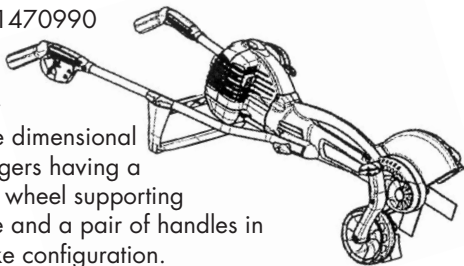

Atom machines are environmentally made with our 100% RENEWABLE ELECTRICITY generated at our Sydney factory.

Atom has a policy of continuous product improvement and development and reserves the right to modify the design and appearance of products without notice.

Registration No.s 303811 and 303812 are Registered Designs of Atom Tillers consisting of the shape and configuration of the illustrated tillers.

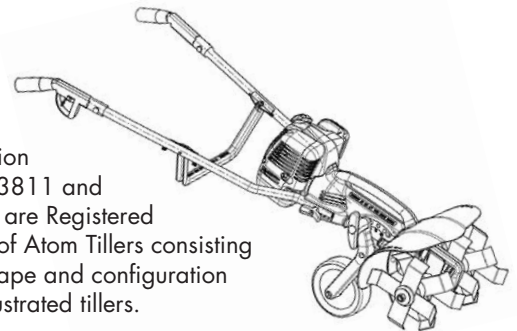

///ATOM®
Dependable Quality

Atom Industries is a division of Solo Industries Pty Ltd – an Australian owned company that invents, designs and manufactures unique and outstanding products for local tough and hard Australian conditions with a history of international award winning gold medals, great backup and service since 1961.

ATOM INDUSTRIES

9 Fred St. Lilyfield 2040 Sydney Australia
Tel: +61(0)2 9810 0194 Fax: +61(0)2 9810 6691
Email: info@atomindustries.com.au
www.atomindustries.com

ATOM INDUSTRIES (NZ) Limited

FREECALL 0800 174 753 Fax: 0800 603 403
Email: info@atomindustries.com.au
www.atomindustries.co.nz