

ZL XL 48 [AGU918013] (005000+)

TABLE OF CONTENTS

AGU918013 Unit	3
AGU918013 Anti-Scalp Wheels & Belt Covers - 42" & 48"	5
AGU918013 Bumpers, Shields & Back Wrap	7
AGU918013 Control Panel	9
AGU918013 Controls	11
AGU918013 Decals - Safety	15
AGU918013 Decals Style - 48"	17
AGU918013 Deck Idlers	19
AGU918013 Deck Lift	21
AGU918013 Deck, Belt, Blades & Spindles - 48"	23
AGU918013 Discharge Chute	25
AGU918013 Electrical	27
AGU918013 Engine - Kawasaki FR691	30
AGU918013 Fenders	33
AGU918013 Foot Pedal	35
AGU918013 Frame	37
AGU918013 Front Footrest	40
AGU918013 Front Wheels & Caster Forks	42
AGU918013 Fuel System - Kawasaki	44
AGU918013 Rear Tyres & Transaxles - 48", 52" & 60"	46
AGU918013 Seat	48
AGU918013 Transaxle Drive	51
AGU918013 Wiring Diagram	53
AGU918013 ZT 2800 Series Transmission - 09483000	55
AGU918013 ZT 2800 Series Transmission - 09483100	58

AGU918013 Unit



Rendered by LeadVenture, Inc.

AGU918013 Unit

Ref Number	Part Number	Part Description	Context Notes	Quantity
1	AGU918013	ZT XL 48- 23HP KAWASAKI FR651 V-TWIN W/48" FABRICATED DECK ZT2800 TRANSAXLE		1

AGU918013 Anti-Scalp Wheels & Belt Covers - 42" & 48"

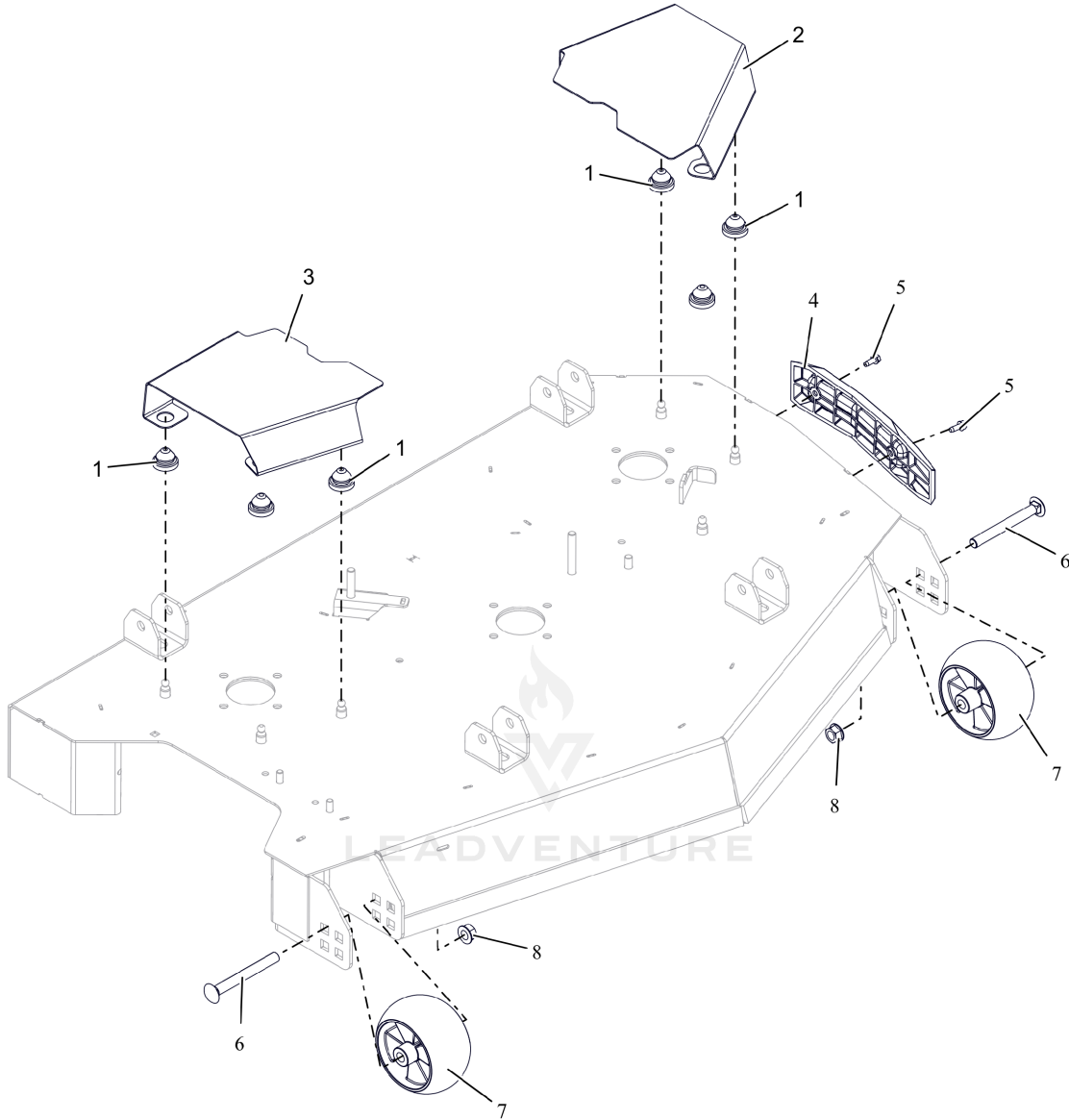

Rendered by LeadVenture, Inc.

AGU918013 Anti-Scalp Wheels & Belt Covers - 42" & 48"

Ref Number	Part Number	Part Description	Context Notes	Quantity
1	AGP07500429	COUPLING, RUBBER PUSH-IN		6
2	AGP09653553	COVER- BELT		1
3	AGP09653653	COVER- RIGHT BELT		1
4	AGP09667100	BUMPER, DECK		1
5	AGP07400135	SCR,TAP .25-20X.625 HWH ZCC		2
6	AGP06200505	BLT,RHNS .50-13X4.50 G5 ZCC NS		2
7	AGP05268800	WHEEL, ANTI SCALP - 5X3 CTR W/RIBS		2
8	AGP06500902	NUT-LK-CTR-FLG .500-13 GG ZCC		2

AGU918013 Bumpers, Shields & Back Wrap

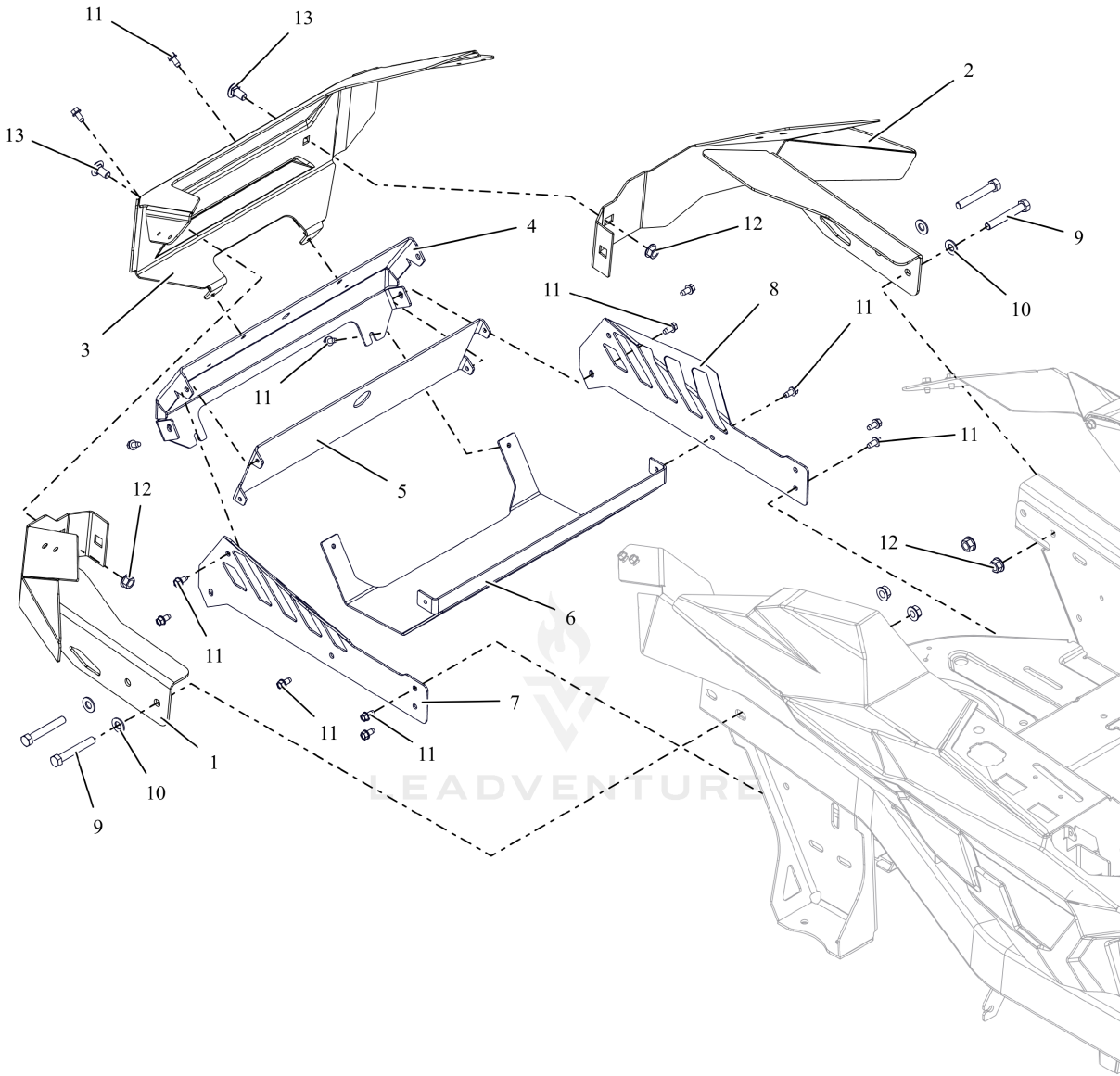

Rendered by LeadVenture, Inc.

AGU918013 Bumpers, Shields & Back Wrap

Ref Number	Part Number	Part Description	Context Notes	Quantity
1	AGP09651751	WLDMT, BUMPER - RH (BLACK)		1
2	AGP09651651	WLDMT, BUMPER - LH (BLACK)		1
3	AGP09653253	PLATE, GRAVELY REAR WRAP (RED)		1
4	AGP09666151	SHIELD, MUFFLER (BLACK)		1
5	AGP09676751	SHIELD, HEAT (BLACK)		1
6	AGP09666051	SHIELD, MUFFLER, GRASS BROWNING (BLACK)		1
7	AGP51801500	KIT, RH MUFFLER GUARD W/ DECALS		1
8	AGP51801400	KIT, LH MUFFLER GUARD W/ DECALS		1
9	AGP05901812	BLT, HEX .38-16X2.50 G5 ZCC		4
10	AGP06401013	WSHR,FLT .406X.812X.065 ZCC		4
11	AGP07400210	SCR-TAP .25-20X.50 HWH ZB500		14
12	AGP06500901	NUT-LK-CTR-FLG .375-16 GF ZCC		6
13	AGP06200432	BTL,RHSSN .375-16 X 0.75 G5 FPB		2

AGU918013 Control Panel

04986400 - KEY, IGNITION

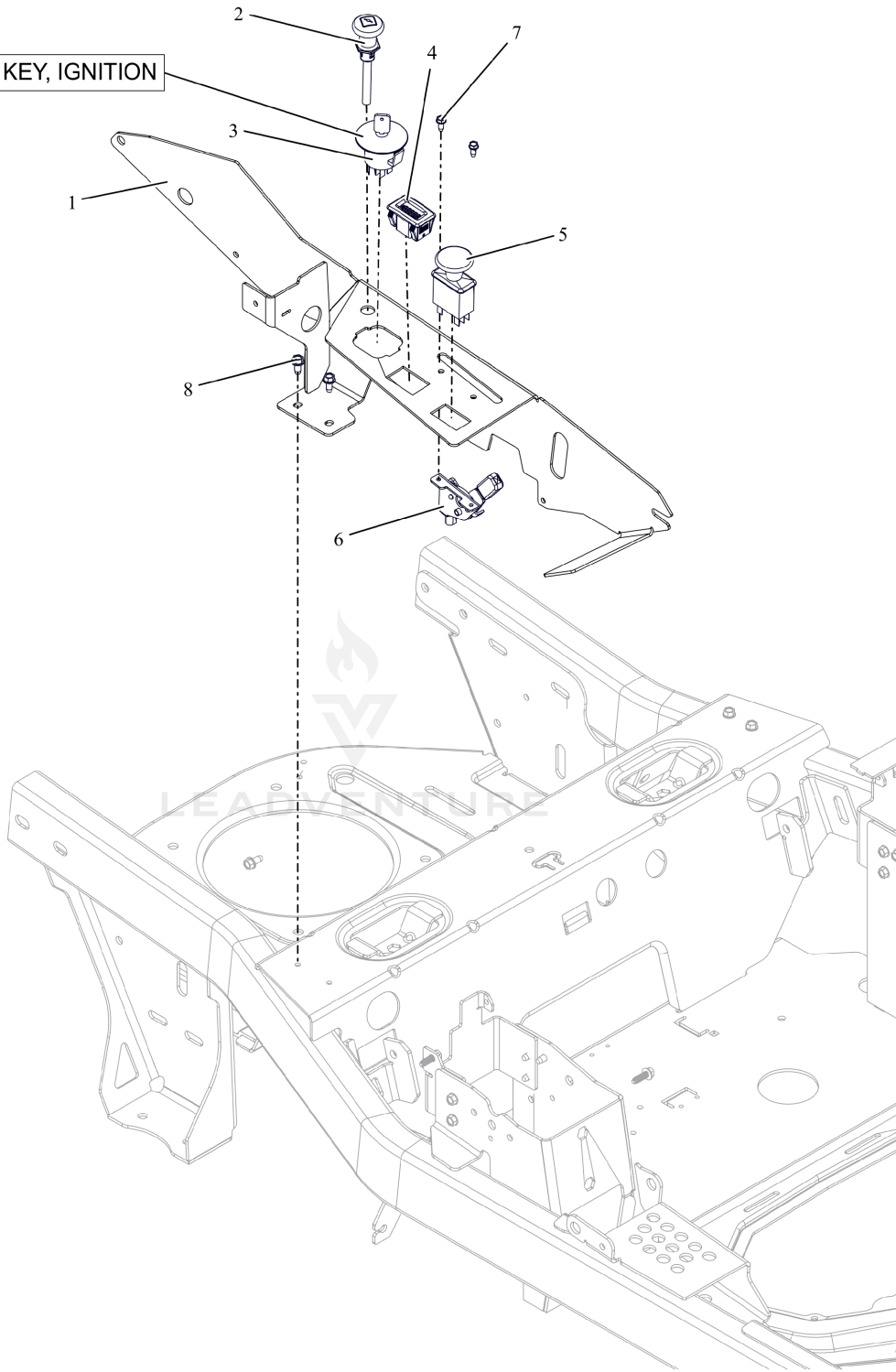

Rendered by LeadVenture, Inc.

AGU918013 Control Panel

Ref Number	Part Number	Part Description	Context Notes	Quantity
1	AGP09666653	WLDMT, CONTROL - GRAVELY-RH (RED)		1
2	AGP06900734	CABLE, CHOKE - SNAP IN 37"		1
3	AGP04974300	KEYSWITCH-IGNITION 4 POS		1
4	AGP09497400	METER, HOUR - NO PRINT		1
5	AGP01545600	SWITCH, CLUTCH		1
6	AGP06900733	CABLE, THROTTLE LH 90DEG 37"		1
7	AGP07400130	SCR,TAP #10-24X.50 HWH TR ZCC		2
8	AGP07400122	SCR-TAP .25-20X.50 HWH ZCC		2
9	AGP04986400	KEY, IGNITION	SERVICE PART COMPONENT	1

AGU918013 Controls

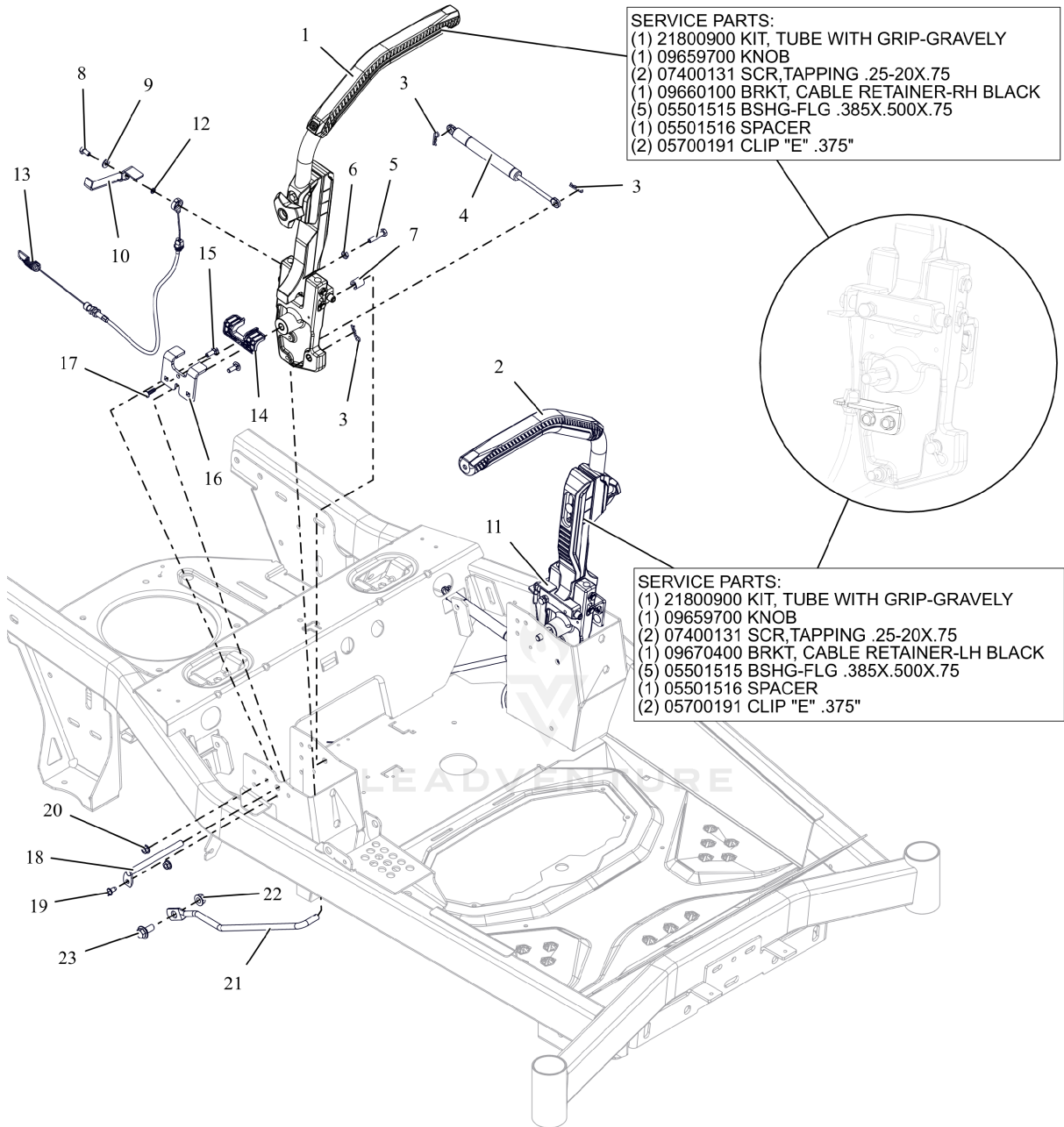

Rendered by LeadVenture, Inc.

AGU918013 Controls

Ref Number	Part Number	Part Description	Context Notes	Quantity
1	AGP09681200	ASM, CONTROLS -RH- GRAVELY		1
2	AGP09681300	ASM, CONTROLS -LH - GRAVELY		1
3	AGP06700222	PIN, HAIR #213 .08X1.19 ZCC		6
4	AGP09670000	DAMPER, STRAIGHT MOUNT		2
5	AGP05902208	BLT, HEX 0.25-20X1.25F GR5 ZCC		2
6	AGP06500908	NUT-JAM .250-20 G2 ZCC		2
7	AGP09670100	SPCR, SNAP - ON .5 X .688		2
8	AGP05901918	BLT, HEX .25-20X.50 G5ZCC EP80		2
9	AGP06401001	WSHR,FLT .281X.625X.065 ZCC		2
10	AGP09676951	BRKT, PARKING BRK ENG R (BLACK)		1
11	AGP09677051	BRKT, PARKING BRK ENG L (BLACK)		1
12	AGP06401236	WSHR-FL-STL 0.25X0.406X0.05 ZCC		2
13	AGP09669900	CABLE, PARK BRAKE		2
14	AGP07500530	STEERING, PLASTIC LINER		2
15	AGP06200307	BLT, RHSN .25-20X.750 G5 ZCC		4
16	AGP09669351	PLATE, BRAKE STOP (BLACK)		2
17	AGP07400101	SCR-TAP #12-14X.75 PLASTITE BLZC		2
18	AGP30135500	PIN, FIXED STEERING PIVOT		2

Ref Number	Part Number	Part Description	Context Notes	Quantity
19	AGP07400122	SCR-TAP .25-20X.50 HWH ZCC		2
20	AGP06500821	NUT-LK-CTR-FLG .25-20 ZC120		4
21	AGP09659900	WIREFORM, STEERING LINKAGE		2
22	AGP06500901	NUT-LK-CTR-FLG .375- 16 GF ZCC		2
23	AGP07002029	BLT, SHLDR .375-16 X .100 X .72		2
24	AGP21800900	KIT, HANDLE WITH GRIP-GRAVELY	SERVICE PART KIT	1
25	AGP09659700	KNOB	SERVICE PART COMPONENT	1
26	AGP07400131	SCR,TAP .25-20X.75 HWH TR ZCC	SERVICE PART COMPONENT	2
27	AGP09660100	BRKT- CABLE RETAINER	SERVICE PART COMPONENT	1
28	AGP05501515	BSHG-FLG .385X.500X.75	SERVICE PART COMPONENT	5
29	AGP05501516	SPACER SLEEVED .385X.500X1.045	SERVICE PART COMPONENT	1
30	AGP05700191	3/8" E RETAINING RING EXTERNAL	SERVICE PART COMPONENT	2
31	AGP21800900	KIT, HANDLE WITH GRIP-GRAVELY	SERVICE PART KIT	1
32	AGP09659700	KNOB	SERVICE PART COMPONENT	1
33	AGP07400131	SCR,TAP .25-20X.75 HWH TR ZCC	SERVICE PART COMPONENT	2
34	AGP09670400	BRKT- CABLE RETAINER LH	SERVICE PART COMPONENT	1
35	AGP05501515	BSHG-FLG .385X.500X.75	SERVICE PART COMPONENT	5
36	AGP05501516	SPACER SLEEVED .385X.500X1.045	SERVICE PART COMPONENT	1

Ref Number	Part Number	Part Description	Context Notes	Quantity
37	AGP05700191	3/8" E RETAINING RING EXTERNAL	SERVICE PART COMPONENT	2

AGU918013 Decals - Safety

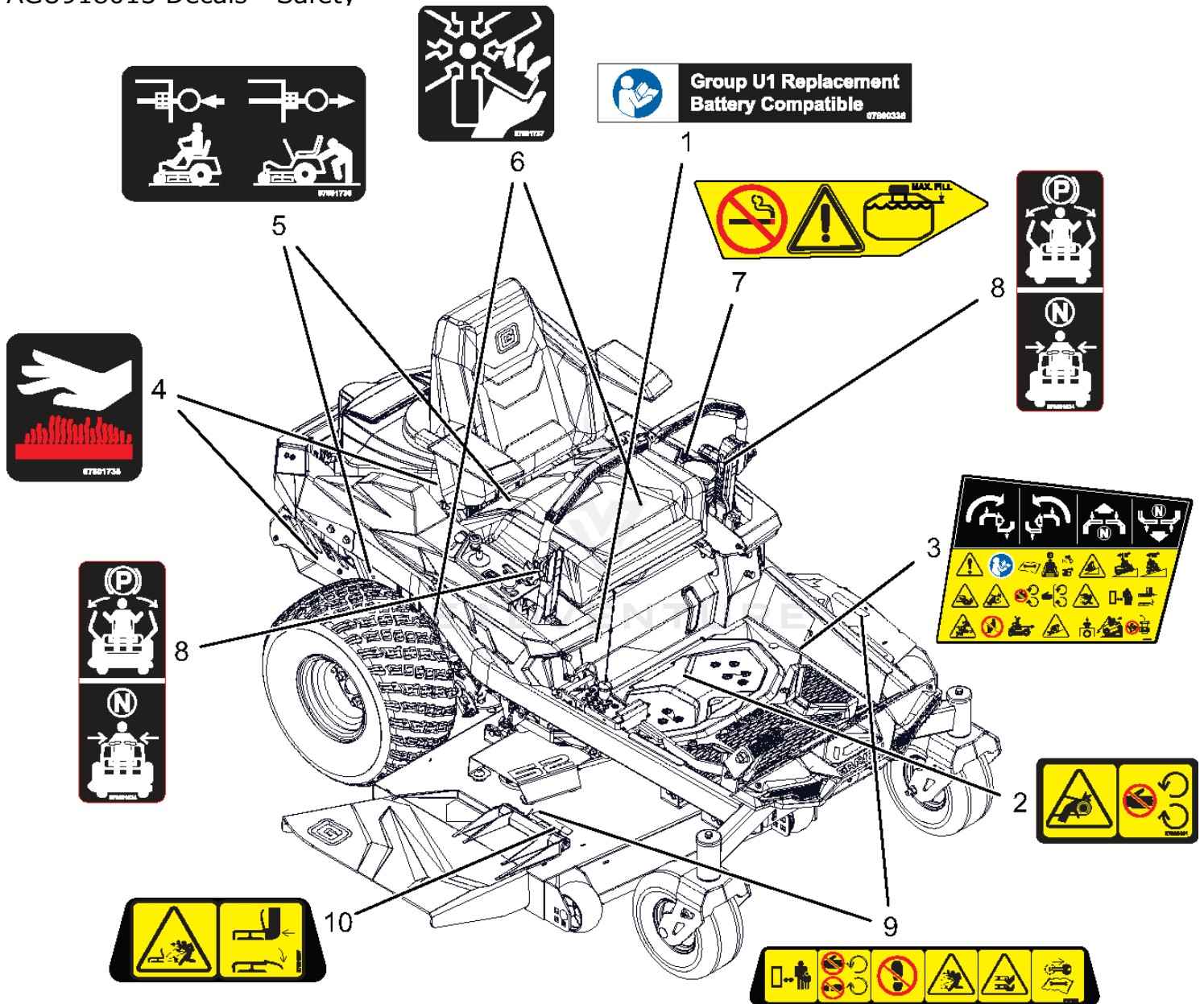

Rendered by LeadVenture, Inc.

AGU918013 Decals - Safety

Ref Number	Part Number	Part Description	Context Notes	Quantity
1	AGP07800336	DECAL, U1 BATTERY REPLACEMENT		1
2	AGP07800401	DECAL, SAFETY - GUARDING		1
3	AGP07801638	DECAL, MAIN SAFETY-INSTRUCTION		1
4	AGP07801735	DECAL, SAFETY HOT SURFACE		2
5	AGP07801736	DECAL, TRANSAXLE DISCONNECT		2
6	AGP07801737	DECAL, DANGER FAN		2
7	AGP07801833	DECAL, FUEL WARNING		1
8	AGP07801834	DECAL, STEERING BRAKE		2
9	AGP07801836	DECAL, SAFETY - MOWER DECK		2
10	AGP07801837	DECAL, SAFETY - DECK GUARDING		1

AGU918013 Decals Style - 48"

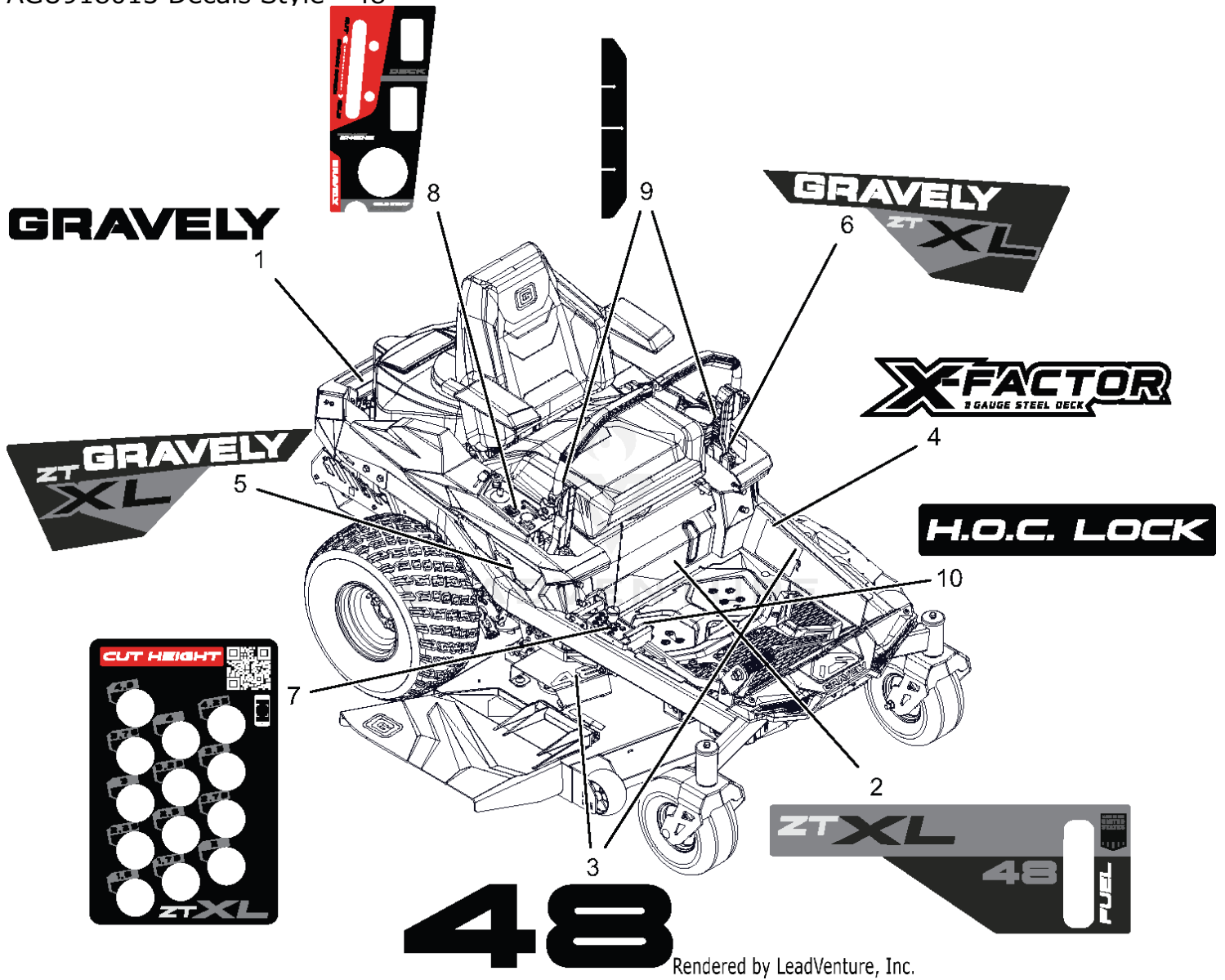

Rendered by LeadVenture, Inc.

AGU918013 Decals Style - 48"

Ref Number	Part Number	Part Description	Context Notes	Quantity
1	AGP07801708	DECAL, GRAVELY		1
2	AGP07801909	DECAL- ZTXL 48-KICK PLATE		1
3	AGP07801704	DECAL, DECK 48"		2
4	AGP07801707	DECAL, DECK X-FACTOR		1
5	AGP07801709	DECAL, ZT XL FENDER RH		1
6	AGP07801710	DECAL- ZT XL FENDER LH		1
7	AGP07801923	DECAL- HEIGHT OF CUT-XL		1
8	AGP07801713	DECAL, CONTROL PANEL, GRAVELY		1
9	AGP07802103	DECAL, HIRTH INDICATOR		2
10	AGP07801835	DECAL- HOC LOCK		1

AGU918013 Deck Idlers

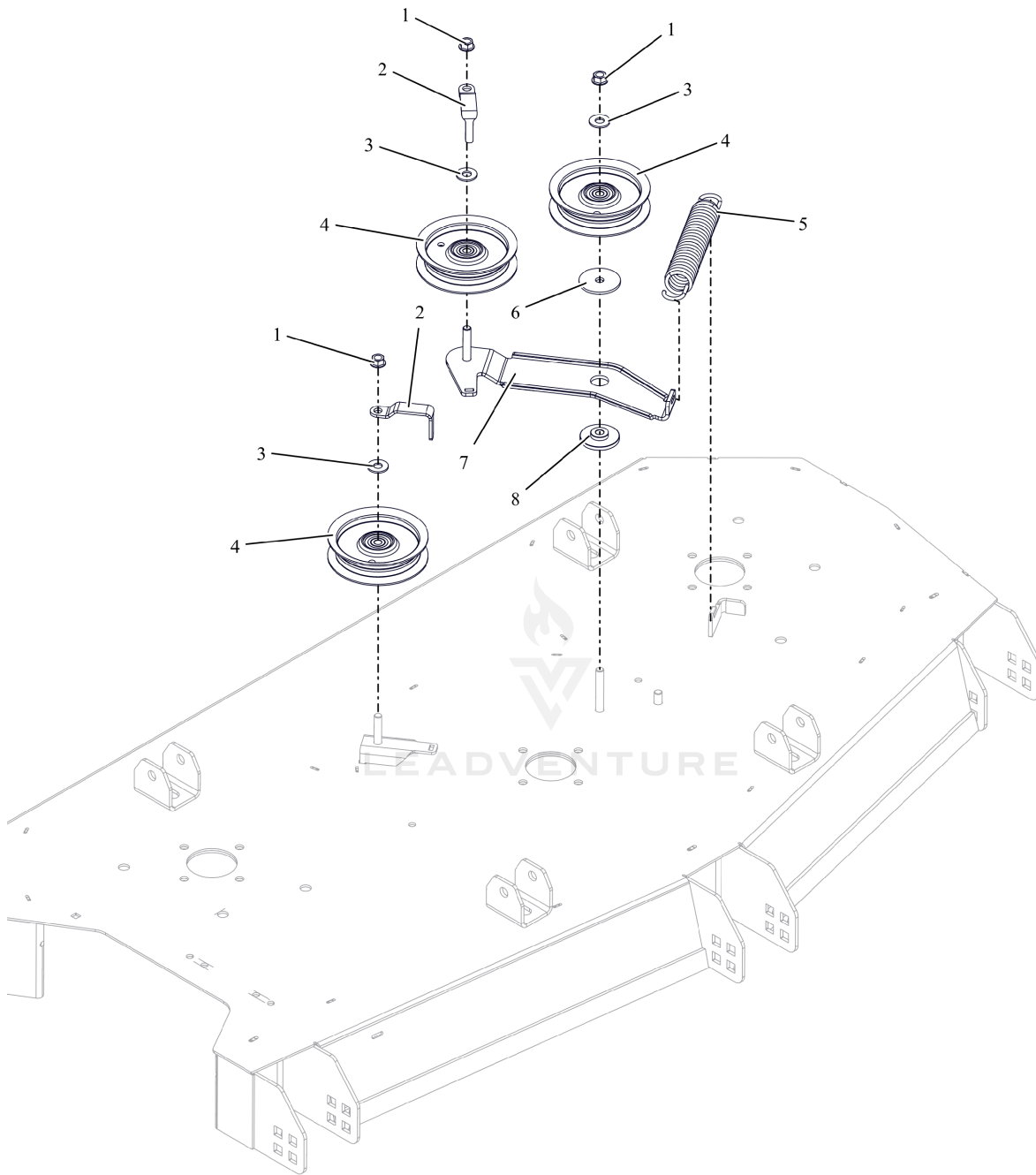

Rendered by LeadVenture, Inc.

AGU918013 Deck Idlers

Ref Number	Part Number	Part Description	Context Notes	Quantity
1	AGP06500901	NUT-LK-CTR-FLG .375-16 GF ZCC		3
2	AGP09665251	FINGER, BELT (BLACK)		2
3	AGP06401008	WSHR,FLT .438X1.00X.083 ZCC		3
4	AGP07350100	IDLER, FLAT - 4.06" X .75"		3
5	AGP08300627	SPRG, EXTENSION		1
6	AGP06401221	WSHR-FL-STL 0.406X2X0.125 ZCC		1
7	AGP09661451	WLDMT, TENSIONER ARM (BLACK)		1
8	AGP05501509	BUSHING FLANGED		1

AGU918013 Deck Lift

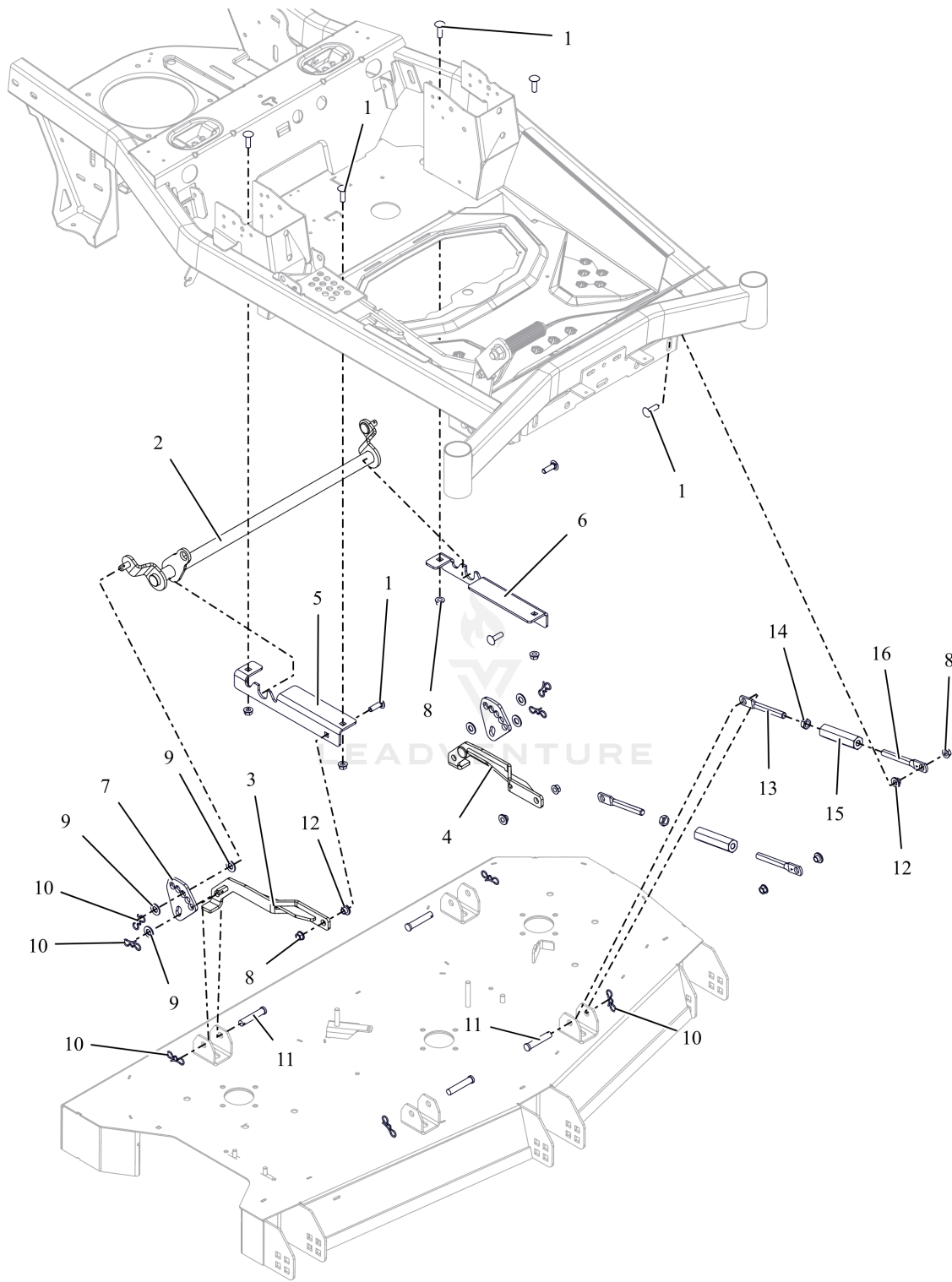

Rendered by LeadVenture, Inc.

AGU918013 Deck Lift

Ref Number	Part Number	Part Description	Context Notes	Quantity
1	AGP06200236	BLT,RHSSN .38-16X1.25 G5 ZCC		8
2	AGP09656851	WLDMT- DECK LIFT SHAFT		1
3	AGP09658351	WLDMT, REAR DECKLIFT BRKT- RH (BLACK)		1
4	AGP09658451	WLDMT, REAR DECKLIFT BRKT- LH (BLACK)		1
5	AGP09660951	BRKT, LIFT MOUNTING (BLACK)		1
6	AGP09660851	PLATE, DECK LIFT MTG-LH (BLACK)		1
7	AGP09658551	BRKT, DECK HEIGHT ADJUSTER		2
8	AGP06500901	NUT-LK-CTR-FLG .375-16 GF ZCC		8
9	AGP06443300	WSHR-FL-NYL .518X1.000X.080		6
10	AGP06700220	PIN, BOWTIE .091X1.875 ZCC		8
11	AGP06810700	PIN, CLEVIS .49 X 2.50 BRIGHT ZINC		4
12	AGP05500435	BSHG-FLG .385X.500X.875X.406		4
13	AGP09692700	LINK, DECK - RH		2
14	AGP06500911	NUT-JAM .500-13 G2 ZCC		2
15	AGP06501020	NUT,COUPLER .500 LH/RH		2
16	AGP09661500	ROD, FRONT LIFT - LH THREAD		2

AGU918013 Deck, Belt, Blades & Spindles - 48"

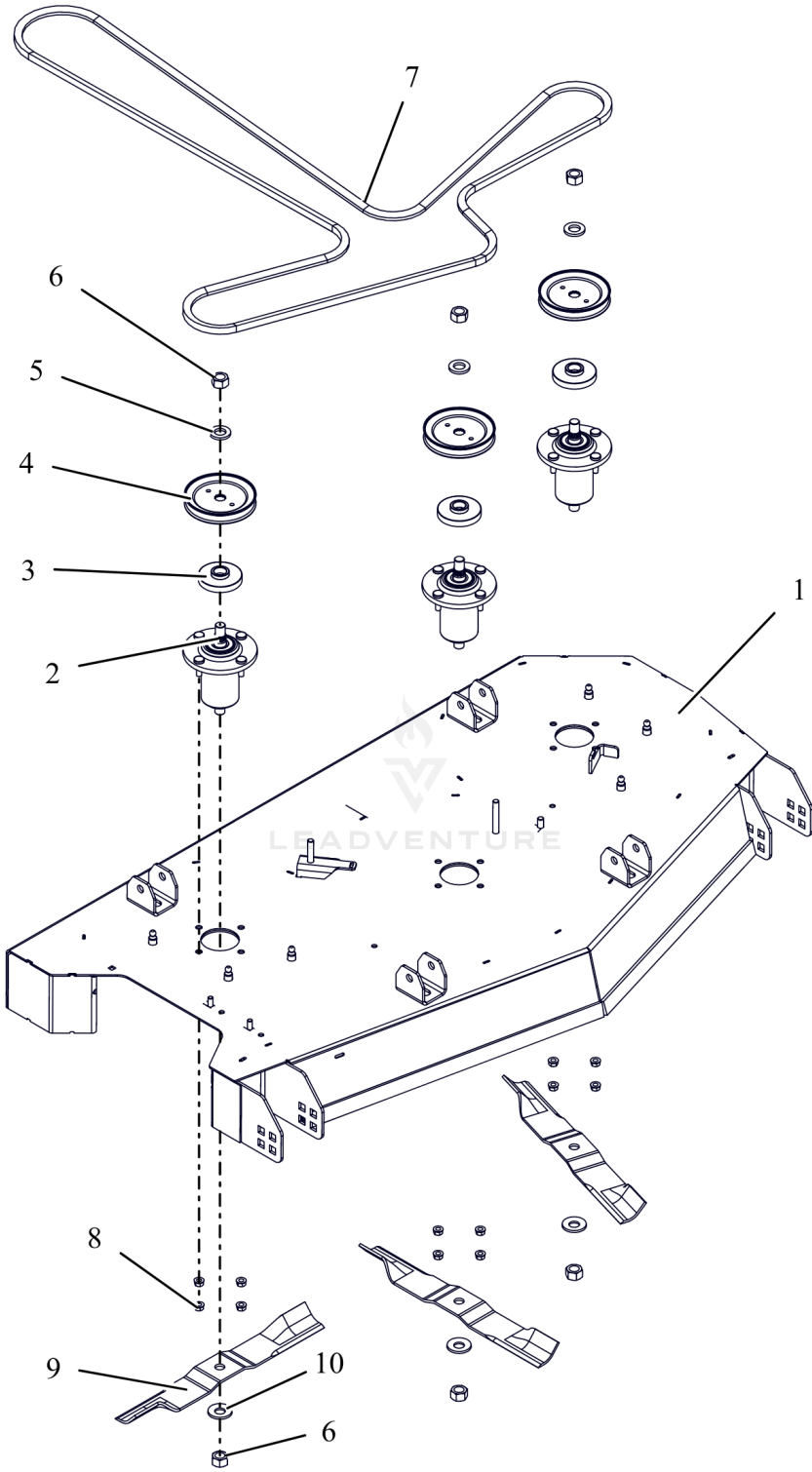

Rendered by LeadVenture, Inc.

AGU918013 Deck, Belt, Blades & Spindles - 48"

Ref Number	Part Number	Part Description	Context Notes	Quantity
1	AGP51800600	KIT, GRAVELY DECK 48" W/ DECALS		1
2	AGP30138800	ASM, ALUMINUM SPINDLE SUB		3
3	AGP09482000	SHIELD, DUST		3
4	AGP07351601	PULLEY, V-4.50 ODX.625 SPLINE ID		3
5	AGP05501510	SPACER		3
6	AGP06500920	NUT-STD .625-18 ZCC		6
7	AGP07200920	V-BELT, HA SECTION		1
8	AGP06500840	NUT,LK-CTR-FLG .31-18 GF ZCC		12
9	AGP09659000	BLADE, MOWER 16.50"		3
10	AGP06445700	WSHR-BLVL .669X1.535X.138		3

AGU918013 Discharge Chute

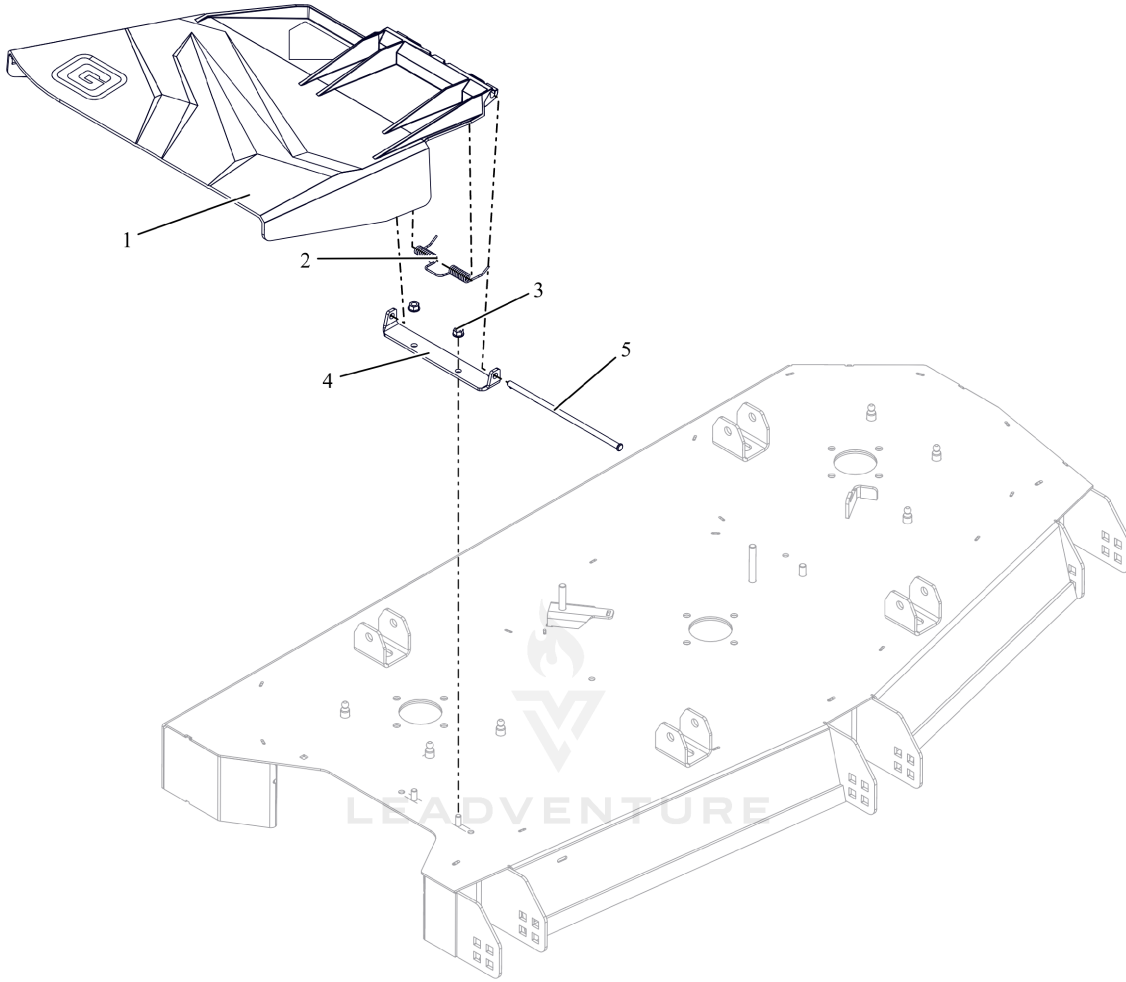

Rendered by LeadVenture, Inc.

AGU918013 Discharge Chute

Ref Number	Part Number	Part Description	Context Notes	Quantity
1	AGP09678000	CHUTE, SIDE DISCHARGE		1
2	AGP08300621	SPRING-TORSION		1
3	AGP06500840	NUT,LK-CTR-FLG .31-18 GF ZCC		2
4	AGP09669553	BRKT- DISCHARGE CHUTE- GRAVELY		1
5	AGP06800219	PIN, SLIC-.312X10.45		1

AGU918013 Electrical

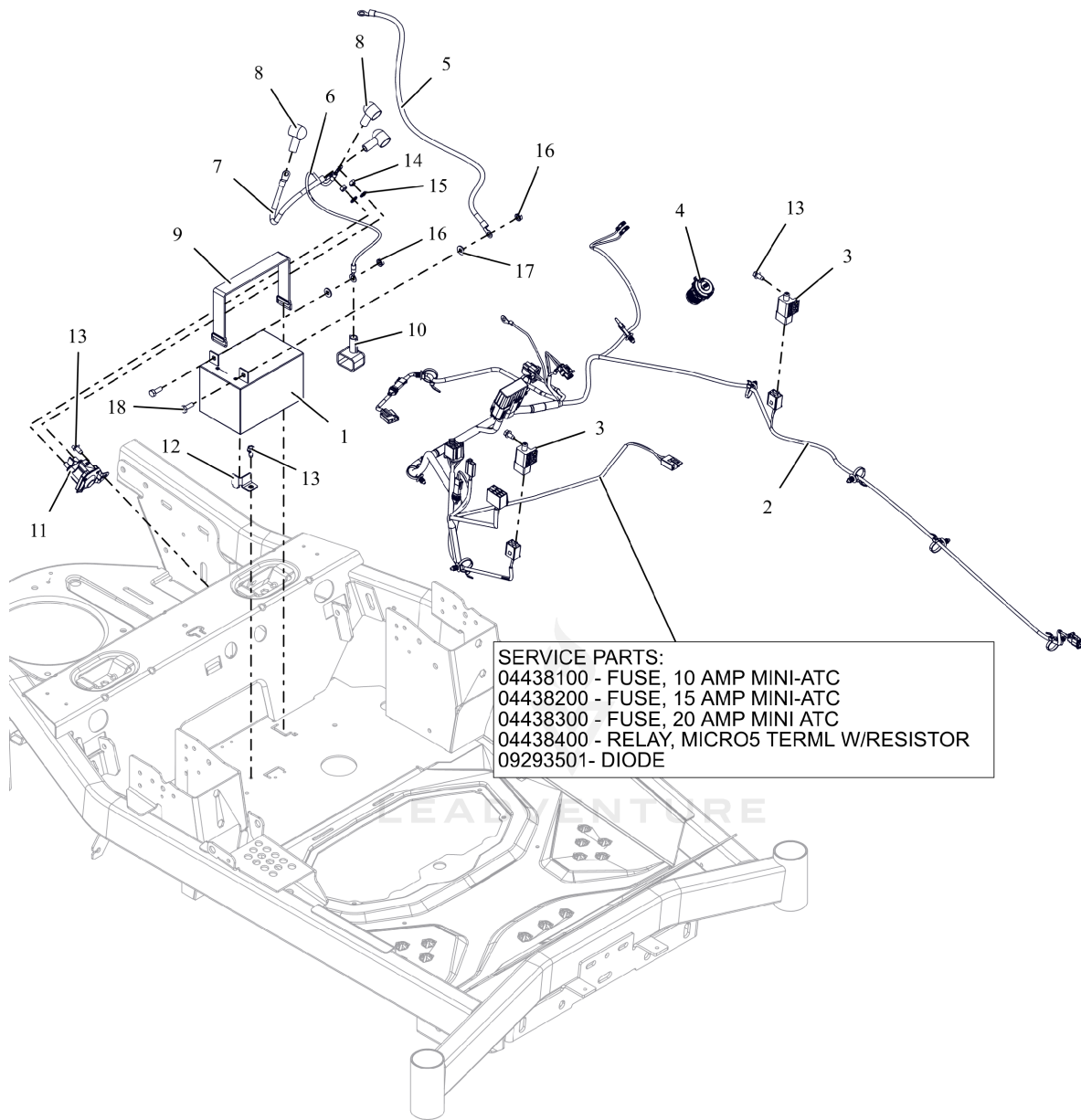

Rendered by LeadVenture, Inc.

AGU918013 Electrical

Ref Number	Part Number	Part Description	Context Notes	Quantity
1	AGP09425500	BATTERY, 12V 12A - 190CCA		1
2	AGP09481300	HARNESS, MAIN IKON 23		1
3	AGP09675800	SWITCH, BRAKE NO-NO-POST & HOLE		2
4	AGP30145700	USB, DUAL PORT USB-C, 12V BLK		1
5	AGP03288100	CABLE-NEGATIVE BATTERY 24.00"		1
6	AGP04787500	CABLE, BATTERY POSITIVE - 18.50"		1
7	AGP04783300	CABLE, POS W/(2)1/4 RING 9.0LG		1
8	AGP07533200	BOOT, EYELET TERMINAL		3
9	AGP07500521	STRAP, RUBBER, BATTERY		1
10	AGP07505700	INSULATOR		1
11	AGP05167200	SOLENOID, STARTER (SEALED)		1
12	AGP30133051	RETAINER, BATTERY CORNER (BLACK)		1
13	AGP07400122	SCR-TAP .25-20X.50 HWH ZCC		4
14	AGP06500925	NUT-STD M6-1.0 ZCC		2
15	AGP06300118	WSHR,LK-EXT.262X.502X.026 ZCC		2
16	AGP06500921	NUT-KEPS .250-20 ZCC		2
17	AGP06401001	WSHR,FLT .281X.625X.065 ZCC		2
18	AGP05901716	BLT, HEX .25-20X.75 G5 ZCC		2
19	AGP04438100	FUSE,10 AMP MINI-ATC	SERVICE PART COMPONENT	1

Ref Number	Part Number	Part Description	Context Notes	Quantity
20	AGP04438200	FUSE,15 AMP MINI-ATC	SERVICE PART COMPONENT	1
21	AGP04438300	FUSE,20 AMP MINI ATC	SERVICE PART COMPONENT	1
22	AGP04438400	RELAY,MICRO5 TERML W/RESISTOR	SERVICE PART COMPONENT	1
23	AGP09293501	DIODE, CONNECTOR SHELL	SERVICE PART COMPONENT	1

AGU918013 Engine - Kawasaki FR691

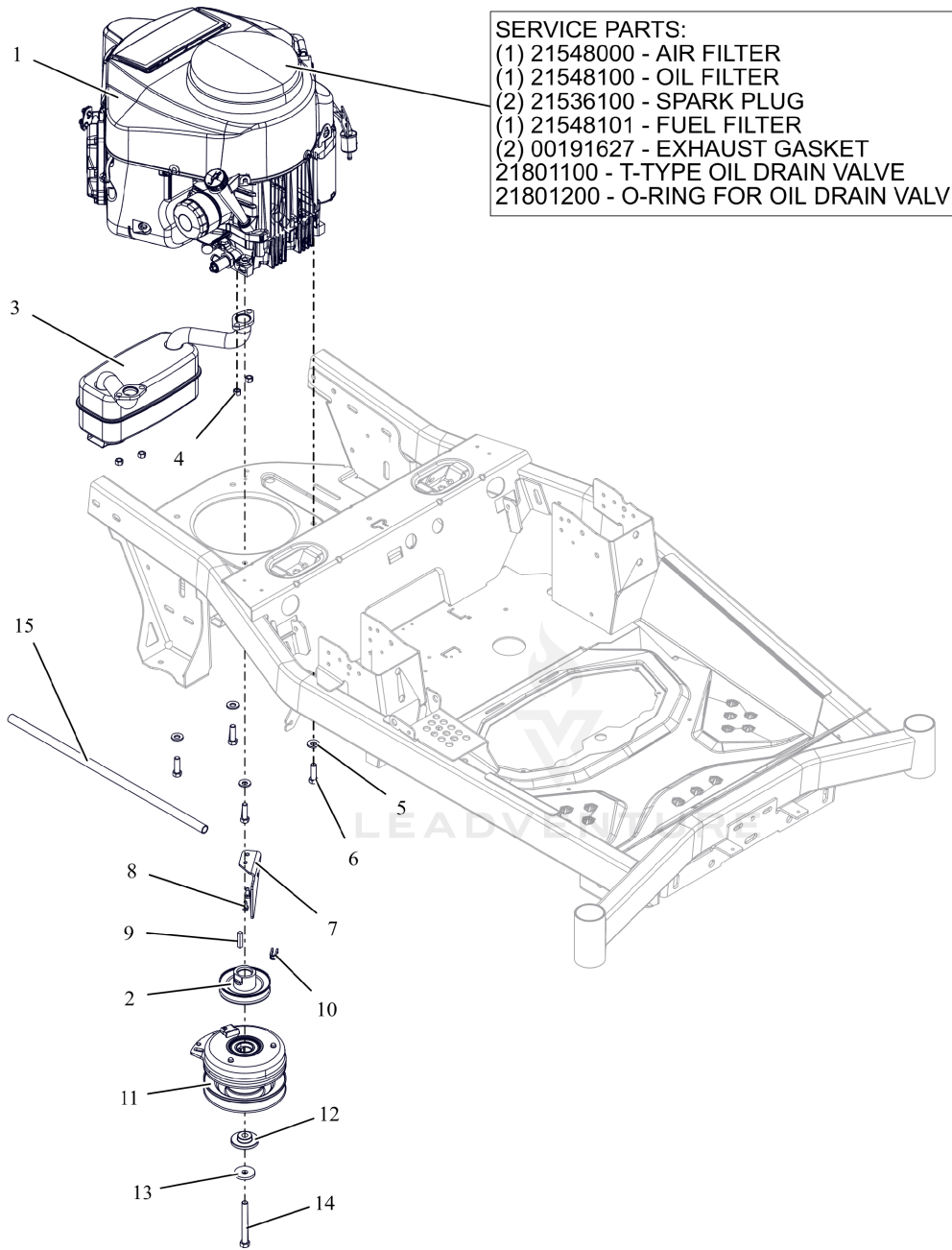

Rendered by LeadVenture, Inc.

AGU918013 Engine - Kawasaki FR691

Ref Number	Part Number	Part Description	Context Notes	Quantity
1	AGP08200717	ENGINE, KAWASAKI FR691 23HP		1
2	AGP07351400	WLDMT, PULLEY 3.75 OD X 1.003 ENGINE		1
3	AGP05088300	MUFFLER - KAWASAKI		1
4	AGP06500919	NUT-LK-TOP-FLG M8 ZCC		4
5	AGP06400927	WASHER, 3/8" SPRING DISC		4
6	AGP05901808	BLT, HEX .38-16X1.25 G5 ZCC NT		4
7	AGP09656751	BRKT, CLUTCH STOP (BLACK)		1
8	AGP07400122	SCR-TAP .25-20X.50 HWH ZCC		2
9	AGP06603400	KEY-SQ .25 X 1.25 X .25 SAE		1
10	AGP30145600	BSHG, CLUTCH		1
11	AGP09481100	CLUTCH, WARNER-IXR-18211		1
12	AGP05501206	BSHG-FLG .469X1.06X.574X2.0		1
13	AGP06400936	WASHER, 7/16" SPRING DISK		1
14	AGP05902124	BLT, HEX 0.4375-20X3.5 G8 ZCC NT		1
15	AGP30143000	HOSE, OIL DRAIN		1
16	AGP21548000	AIR FILTER, KAWASAKI FR	SERVICE PART COMPONENT	1
17	AGP21548100	OIL FILTER, KAWASAKI FR	SERVICE PART COMPONENT	1
18	AGP21536100	PLUG, SPARK	SERVICE PART COMPONENT	2
19	AGP21548101	FUEL FILTER-KAWASAKI FR	SERVICE PART COMPONENT	1

Ref Number	Part Number	Part Description	Context Notes	Quantity
20	AGP00191627	GASKET, MUFFLER S/O	SERVICE PART COMPONENT	2
21	AGP21801100	T-TYPE OIL DRAIN VALVE	SERVICE PART COMPONENT	1
22	AGP21801200	O-RING FOR OIL DRAIN VALVE	SERVICE PART COMPONENT	1

AGU918013 Fenders

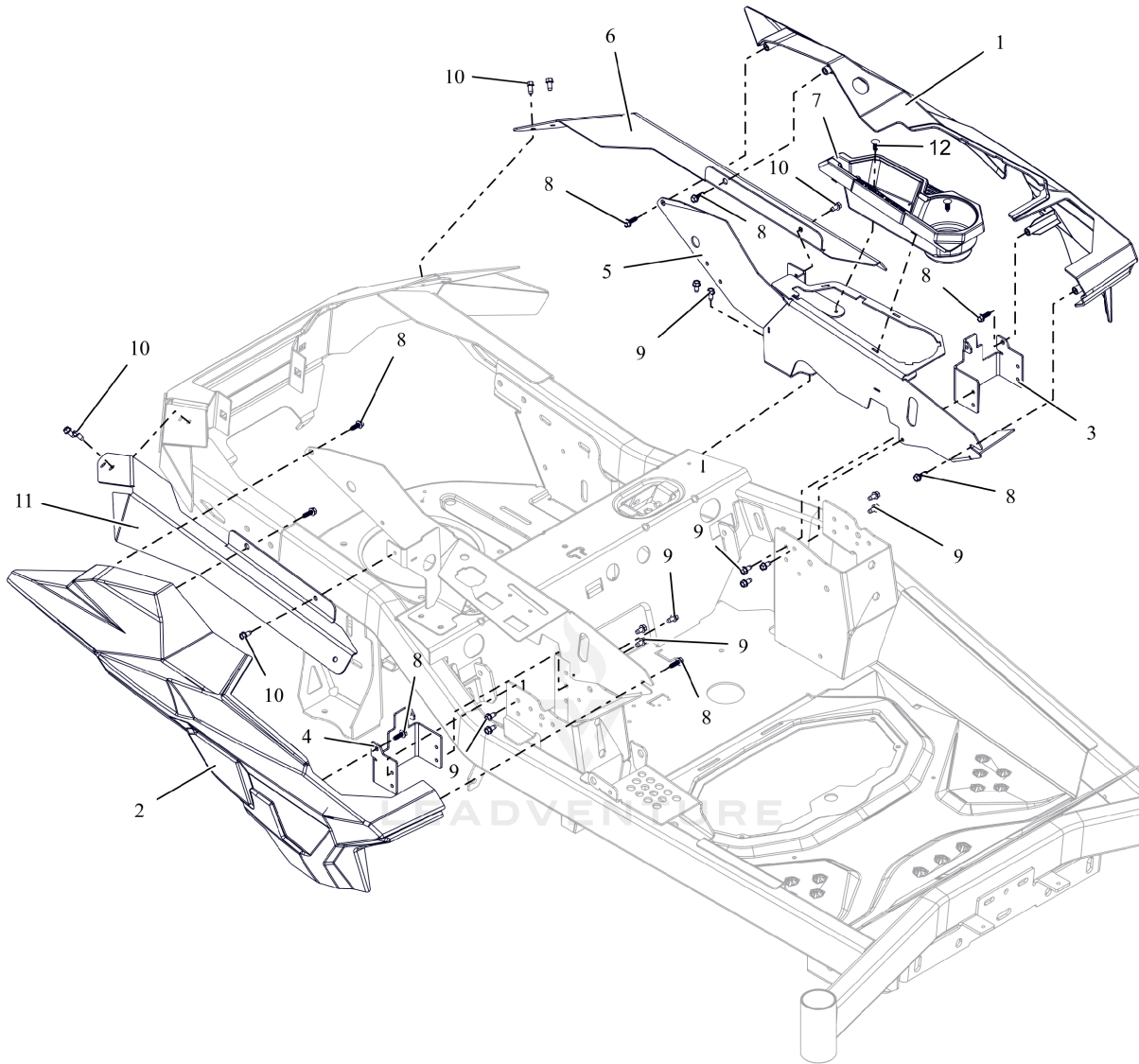

Rendered by LeadVenture, Inc.

AGU918013 Fenders

Ref Number	Part Number	Part Description	Context Notes	Quantity
1	AGP51801300	KIT, LH GRAVELY FENDER W/DECAL		1
2	AGP09662200	FENDER, RH-GRAVELY		1
3	AGP09667551	BRKT, FRONT FENDER MOUNT (RH) (BLACK)		1
4	AGP09667651	BRKT, FRONT FENDER MOUNT (LH) (BLACK)		1
5	AGP09666753	WLDMT, CONTROL PANEL-LH-GRAVELY (RED)		1
6	AGP09670251	BRKT, FENDER MOUNT-RH-GRAVELY		1
7	AGP09676300	HOLDER, CUP - GRAVELY		1
8	AGP06100231	SCR, PLASTITE-HWH 0.25 X 0.75 ZC120		8
9	AGP07400122	SCR-TAP .25-20X.50 HWH ZCC		12
10	AGP07400210	SCR-TAP .25-20X.50 HWH ZB500		6
11	AGP09670351	BRKT, FENDER MOUNT-LH		1
12	AGP07500125	RIVET, .25 NYLON PANEL		2

AGU918013 Foot Pedal

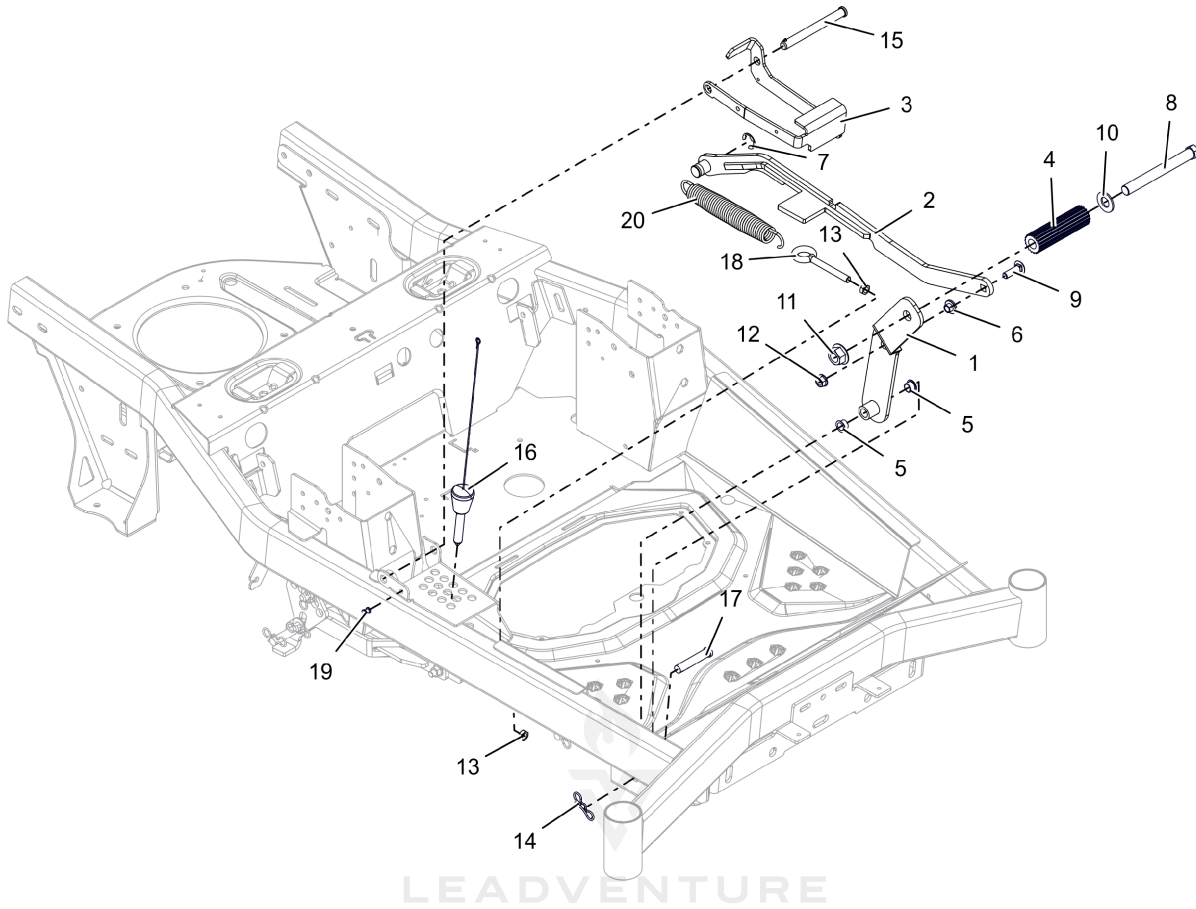

Rendered by LeadVenture, Inc.

AGU918013 Foot Pedal

Ref Number	Part Number	Part Description	Context Notes	Quantity
1	AGP09658651	WLDMT- FOOT PEDAL		1
2	AGP09660451	LINK, DECK LIFT		1
3	AGP09663651	WLDMT- TRANSPORT LOCK		1
4	AGP05120951	ROD, FOOT PEDAL (BLACK)		1
5	AGP05500026	BUSHING, POLYLINER-.50 SPLIT		2
6	AGP05500435	BSHG-FLG .385X.500X.875X.406		1
7	AGP05700218	RING, RETAINING-E .750X.050		1
8	AGP05901730	BLT, HEX .62-11X5.50 G5 FBP		1
9	AGP06200236	BLT,RHSSN .38-16X1.25 G5 ZCC		1
10	AGP06401039	WSHRFLT 5/8SAE CARBHARD FBP		1
11	AGP06500835	NUT,FLG-TOP LK .625-11 FBP		1
12	AGP06500901	NUT-LK-CTR-FLG .375-16 GF ZCC		1
13	AGP06500910	NUT-JAM .375-16 G2 ZCC		2
14	AGP06700220	PIN, BOWTIE .091X1.875 ZCC		1
15	AGP06800201	PIN, SLIC-.500X4.97X4.55 - ZC		1
16	AGP06800218	PIN, MAGNETIC .50X2.70		1
17	AGP06810700	PIN, CLEVIS .49 X 2.50 BRIGHT ZINC		1
18	AGP07001701	BOLT,EYE .38-16X4.50,.75"EYE		1
19	AGP07001918	POST, & SCREW, PUSH LOCK .25 X .25		1
20	AGP08300802	SPRING, EXTENSION		1

AGU918013 Frame

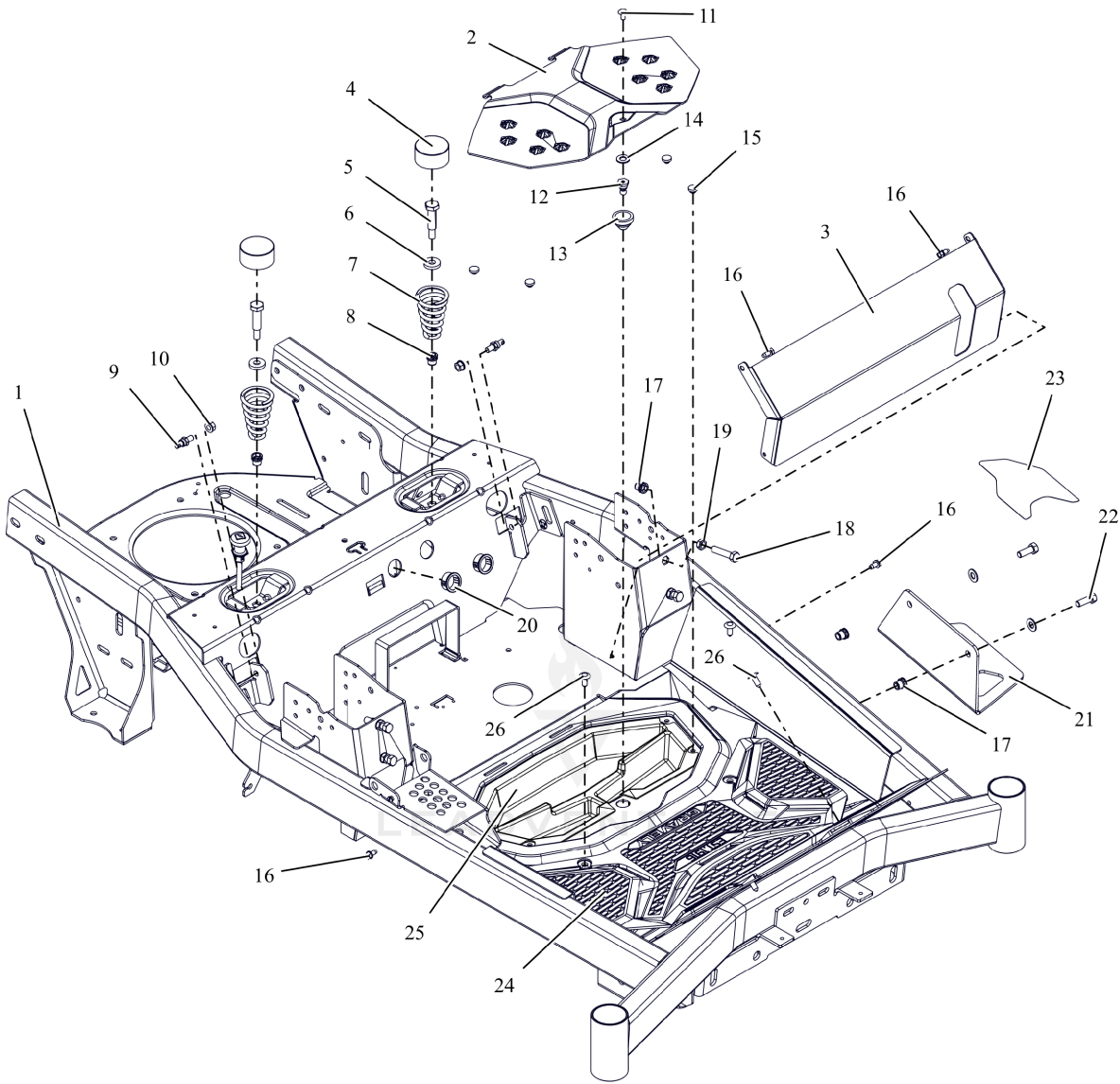

Rendered by LeadVenture, Inc.

AGU918013 Frame

Ref Number	Part Number	Part Description	Context Notes	Quantity
1	AGP51801000	KIT, GRAVELY FRAME W/ DECALS		1
2	AGP51801700	KIT, GRAVELY ACCESS PLT W/ DECAL		1
3	AGP09666853	PLATE, FRONT KICK-RED		1
4	AGP00337700	HUB CAP		2
5	AGP05902130	BLT, SHLDR .50X1.50 .375-16 LP ZCC		2
6	AGP06401108	WSHR, FLT .406X1.00X.188 ZCC		2
7	AGP08300021	SPRING, SEAT		2
8	AGP07001805	NUT, THREADED INSERT .38- 16 ZC120		2
9	AGP05171400	COUPLER, DAMPER MOUNT		2
10	AGP06500904	NUT-LK-TOP-FLG .312-18 GF ZCC		2
11	AGP06200305	BLT, RHSSN.25-20X.500 G5 ZCC		1
12	AGP05275900	STUD, BALL FEMALE .250-20 THREAD		1
13	AGP07500429	COUPLING, RUBBER PUSH-IN		1
14	AGP06401013	WSHR,FLT .406X.812X.065 ZCC		3
15	AGP07503100	BUMPER GROMMET		4
16	AGP07400122	SCR-TAP .25-20X.50 HWH ZCC		4
17	AGP07001805	NUT, THREADED INSERT .38- 16 ZC120		6
18	AGP05901612	BLT, HEX .38-16X1.75F G5 ZCC		4
19	AGP06500910	NUT-JAM .375-16 G2 ZCC		4
20	AGP07500308	BSHG, PANEL SNAP .937X1.11X.56		4

Ref Number	Part Number	Part Description	Context Notes	Quantity
21	AGP09655951	STEP, (BLACK)		1
22	AGP05901721	BLT, HEX .38-16X1.00 G8ZCCEP30		2
23	AGP09693800	GRIP, TAPE - STEP-GRAVELY		1
24	AGP09497200	MAT, RUBBER FOOTBOARD-ZT XL		1
25	AGP09696600	INSERT, GRAVELY STORAGE		1
26	AGPP80-332- A	XMAS TREE FASTNER-BLACK		4

AGU918013 Front Footrest

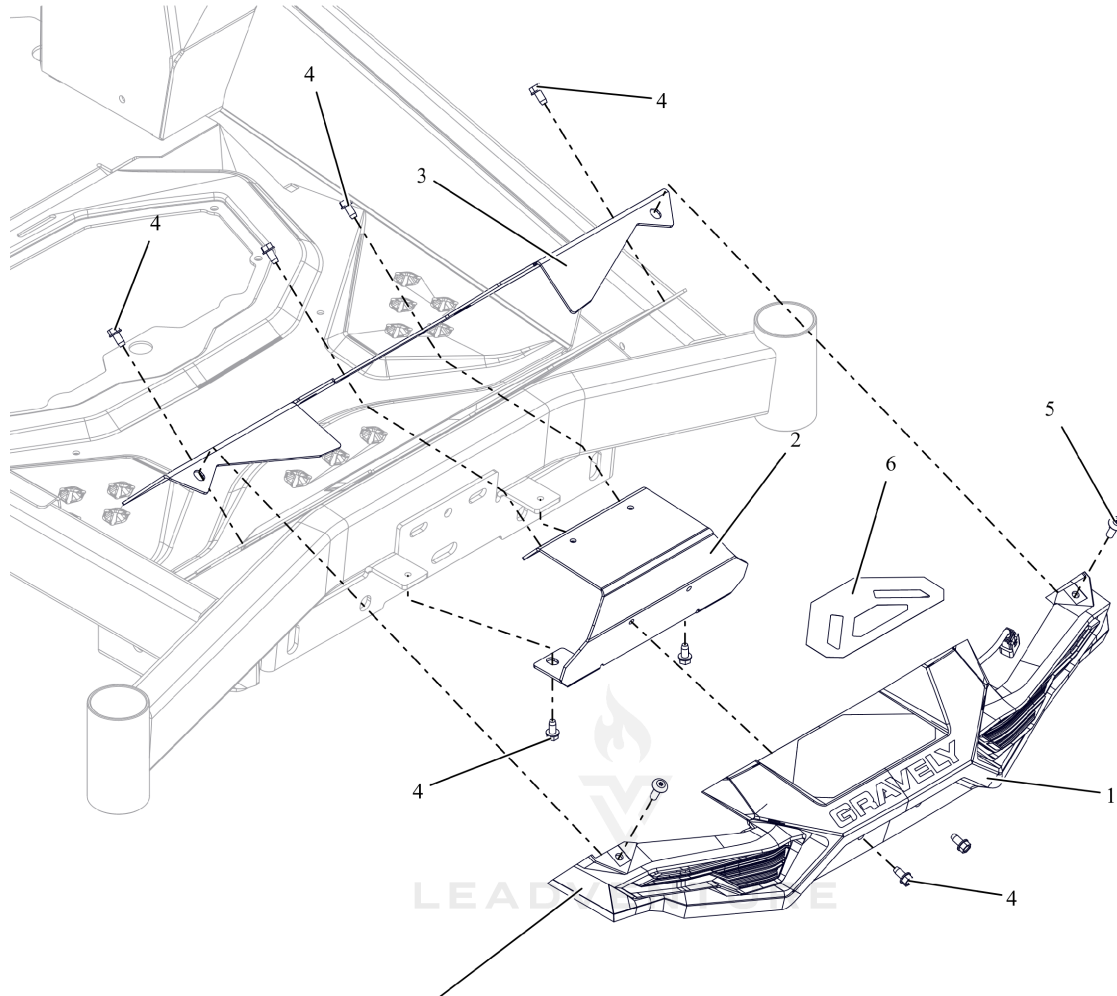

- SERVICE PARTS:**
(1) 09652301 - BEZEL, LIGHT -GRAVELY
(1) 09652302 - HEADLAMP, WITH HARNESS-GRAVELY
(2) 09495006 - NUT, RETAINER .250-20 UNC
(2) 09495007 - SCREW, PAN HD #10 X 1/2 PLASTIC THREAD FORMING

Rendered by LeadVenture, Inc.

AGU918013 Front Footrest

Ref Number	Part Number	Part Description	Context Notes	Quantity
1	AGP09652300	ASSY, HEADLIGHT/BEZEL-GRAVELY		1
2	AGP09672153	BRKT,FRT FACIA-LOWER-GRAVELY		1
3	AGP09672253	BRKT, FRT FACIA UPPER-GRAVELY		1
4	AGP07400210	SCR-TAP .25-20X.50 HWH ZB500		8
5	AGP06100313	SCR, MCH .25-20 X .750 TXTR ZB500		2
6	AGP09694000	GRIP, TAPE-FRONT STEP-GRAVELY		1
7	AGP09652301	BEZEL LIGHT-GRAVELY	SERVICE PART COMPONENT	1
8	AGP09652302	HEADLAMP, WITH HARNESS - GRAVELY	SERVICE PART COMPONENT	1
9	AGP09495006	NUT, RETAINING 1/4-20 UNC	SERVICE PART COMPONENT	2
10	AGP09495007	SCREW, PAN HD #10 X 1/2" PLASTIC THREAD FORMING	SERVICE PART COMPONENT	2

AGU918013 Front Wheels & Caster Forks

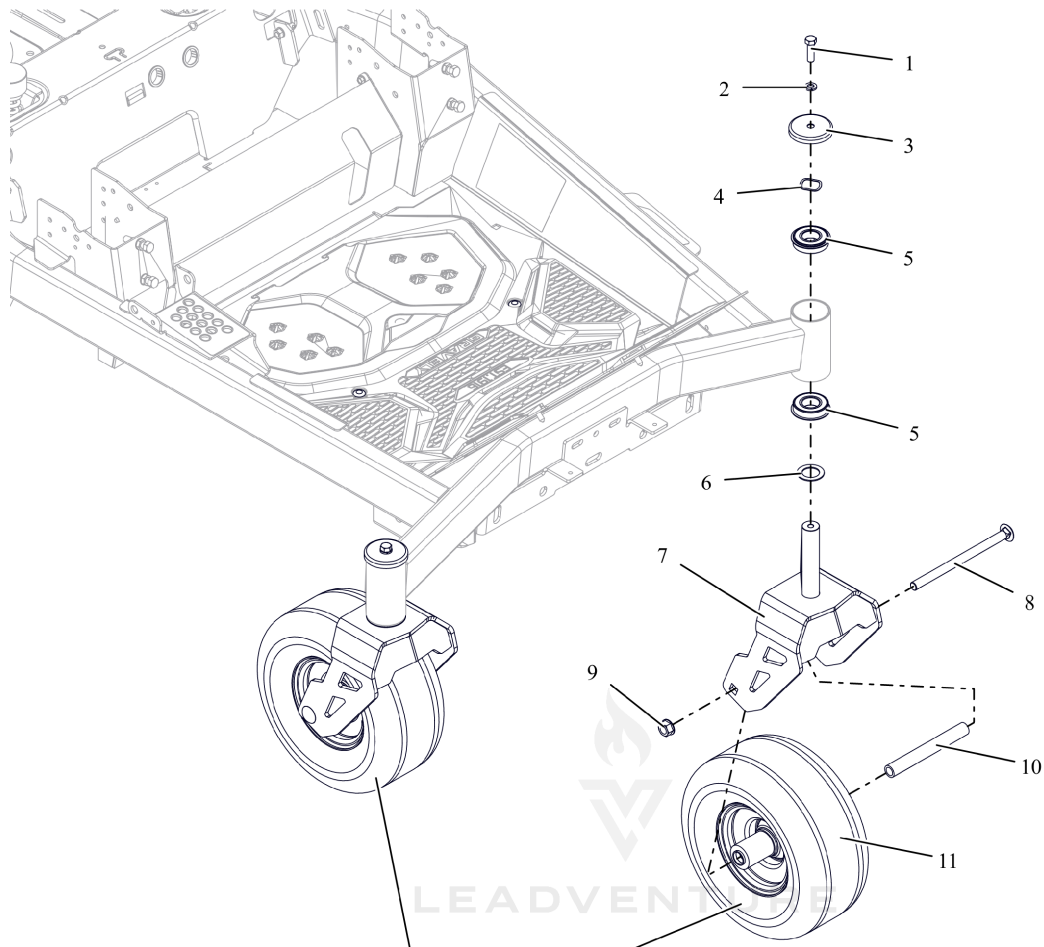

05400726 - BRG, .75 ID X 1.375 OD
07101236 - TIRE, 11 X 6-5 SMOOTH
07101534 - TUBE, 11X6.00-5

Rendered by LeadVenture, Inc.

AGU918013 Front Wheels & Caster Forks

Ref Number	Part Number	Part Description	Context Notes	Quantity
1	AGP05902203	BLT, HEX 0.375-16X1.25 GR5 ZB500		2
2	AGP06300130	WSHR, LK-REG 0.377 X 0.094 ZB500		2
3	AGP09692800	SHIELD, AXLE BEARING		2
4	AGP06401030	WSHR-WAVE 1.0X1.25X.028 .145FH		2
5	AGP05400728	BEARING, BALL -2.000 OD X 1.000 ID X .5625 W/RING		4
6	AGP06416600	WSHR-HRD-THRS 1.007X1.542X.062		2
7	AGP09657853	WMT-CASTER FORK-MY23- XL		2
8	AGP06200509	BOLT, RHNS .50-13X7.50 G5 ZCC NS		2
9	AGP06500902	NUT-LK-CTR-FLG .500-13 GG ZCC		2
10	AGP00853400	SPACER, FRONT WHEEL (WIDE 6.0)		2
11	AGP07101423	TIRE/WHEEL ASSY 11X6-5		2
12	AGP05434900	BRG-BALL .752X1.380X.500	SERVICE PART COMPONENT	4
13	AGP07101236	TIRE, 11X6-5 Smooth	SERVICE PART COMPONENT	2
14	AGP07101534	Tire Tube, 11/6.0-5	SERVICE PART COMPONENT	2

AGU918013 Fuel System - Kawasaki

Ref Number	Part Number	Part Description	Context Notes	Quantity
1	AGP09670900	ASM, FUEL TANK - IKON 23		1
2	AGP09671200	STRAP, TANK HOLD DOWN		1
3	AGP03278100	1 INCH OF HOSE, .25 LOW-PERM BULK GAS		1
4	AGP04745900	HOSE, .188 30R7 BULK		1
5	AGP09190200	CAP, FUEL - 2.25 RATCHET INLET VENT		1
6	AGP03278800	CLAMP, FUEL LINE		2
7	AGP04097700	CLAMP-HOSE, SPRING .188		2
8	AGP06500821	NUT-LK-CTR-FLG .25-20 ZC120		1
9	AGP07001712	CLIP, T, .38-.50		1
10	AGP05106200	ASM, IKON FUEL PICK-UP	SERVICE PART COMPONENT	1
11	AGP30126500	GROMMET, VENT VALVE	SERVICE PART COMPONENT	1
12	AGP30126800	VALVE, VENT	SERVICE PART COMPONENT	1
13	AGP07500206	BSHG-FLG .375X1.062X.625 NITR	SERVICE PART COMPONENT	1

AGU918013 Rear Tyres & Transaxles - 48", 52" & 60"

07101509 - TIRE, 20X10-8
07108800 - TUBE 18X9.50-8

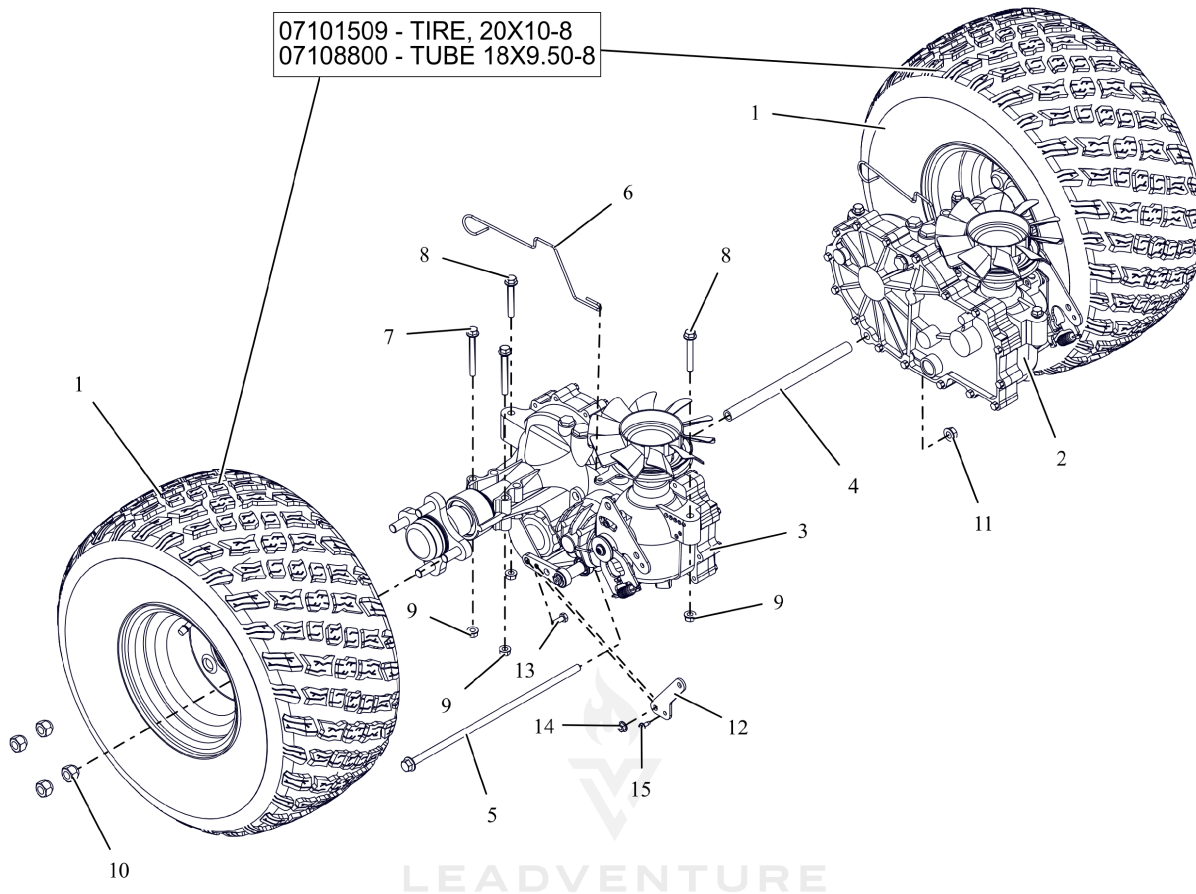

Rendered by LeadVenture, Inc.

AGU918013 Rear Tyres & Transaxles - 48", 52" & 60"

Ref Number	Part Number	Part Description	Context Notes	Quantity
1	AGP07101426	ASM, TIRE/WHL 20X10-8 K3012		2
2	AGP09483100	TRANSAXLE- 2800 - LH		1
3	AGP09483000	TRANSAXLE- 2800 - RH		1
4	AGP05162551	SPCR, TRANSAXLE .406 ID X .630 OD X 9.27 (BLACK)		1
5	AGP05901903	BLT, HEX-FLG 0.375-16X13 GR5 ZC120		1
6	AGP09661600	WIREFORM, DUMP VALVE		2
7	AGP05901911	BLT,HEX-FLG .31-18X2.75 G5 ZCC		4
8	AGP05901910	BLT,HEX-FLG .31-18X2.25 G5 ZCC		4
9	AGP06500840	NUT,LK-CTR-FLG .31-18 GF ZCC		8
10	AGP06500926	NUT, WHEEL .50-20 ZCC		8
11	AGP06500901	NUT-LK-CTR-FLG .375-16 GF ZCC		1
12	AGP09677851	PLATE, ADAPTOR PARKING BRAKE		2
13	AGP05901716	BLT, HEX .25-20X.75 G5 ZCC		2
14	AGP06500821	NUT-LK-CTR-FLG .25-20 ZC120		2
15	AGP07400130	SCR,TAP #10-24X.50 HWH TR ZCC		1
16	AGP07101509	TIRE- 20X10-8	SERVICE PART COMPONENT	2
17	AGP07108800	TUBE 18X6.50/8.50/9.50-8/20X8.00/10.00-8	SERVICE PART COMPONENT	2

AGU918013 Seat

SERVICE PARTS:
(1) 21800600 - KIT, ZTXL CUSTOM BACK COVER
(1) 21800700 - KIT, ZTXL CUSTOM SEAT COVER
(1) 21800800 - KIT, ARMRESTS (CUSTOM PAD)
(1) 02754100 - SWITCH- SNAP MTG N.O.

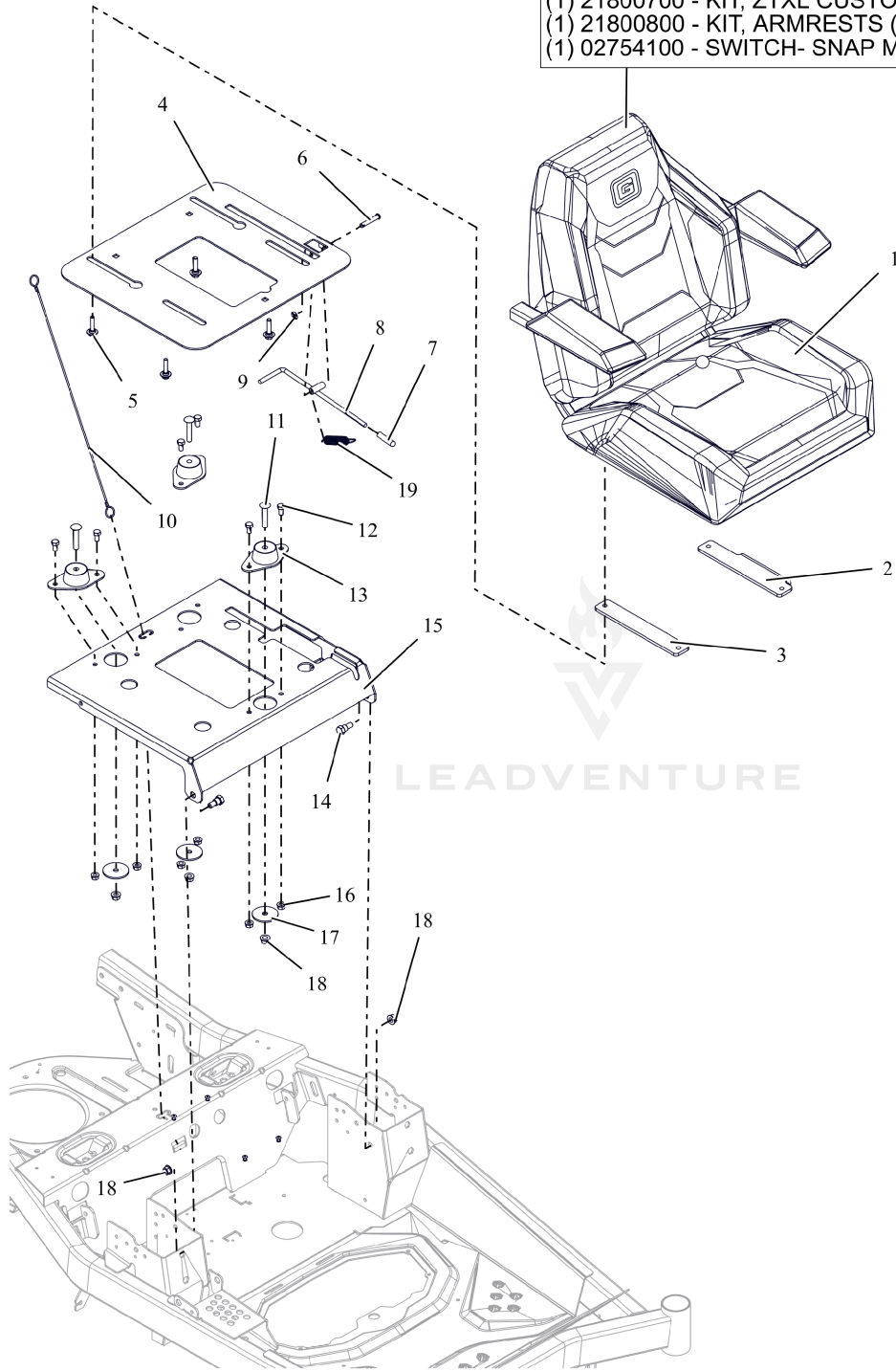

Rendered by LeadVenture, Inc.

AGU918013 Seat

Ref Number	Part Number	Part Description	Context Notes	Quantity
1	AGP30137200	SEAT- ZTXL MY23 (WOOD)		1
2	AGP09664951	PLATE, SEAT ADJUSTER (BLACK)		1
3	AGP09681151	SPCR, SEAT PLATE (BLACK)		1
4	AGP09665453	PLATE,SEAT ISOLATOR		1
5	AGP07001929	BLT, SHLDR .31-18 X .175		4
6	AGP04840500	PIN, CLEV .309X1.75 ZCC		1
7	AGP07500529	GRIP, BLACK RD- .312X1.50		1
8	AGP09679951	WLDMT, LATCH SEAT (BLACK)		1
9	AGP06514900	NUT-PUSH .312		1
10	AGP06900623	LANYARD, SEAT CABLE .093X19.5		1
11	AGP06200323	BLT,RHSSN.375-16X2.00 G5 ZCC		3
12	AGP05901832	BLT, HEX .31-18X.625 G5 ZCC		6
13	AGP07500520	MOUNT, FAIL-SAFE COMPRESSION		3
14	AGP07002030	BLT, SHLDR .50X.38 ZCC		2
15	AGP09665353	BRKT,SEAT,ISOLATOR MTG		1
16	AGP06500840	NUT,LK-CTR-FLG .31-18 GF ZCC		6
17	AGP06401221	WSHR-FL-STL 0.406X2X0.125 ZCC		3
18	AGP06500901	NUT-LK-CTR-FLG .375-16 GF ZCC		5
19	AGP08300628	SPRG, EXTENSION .063 X .653 X 2.755		1

Ref Number	Part Number	Part Description	Context Notes	Quantity
20	AGP21800600	KIT- ZTXL CUSTOM BACK COVER	SERVICE PART KIT	1
21	AGP21800700	KIT- ZTXL CUSTOM SEAT COVER	SERVICE PART KIT	1
22	AGP21800800	KIT- ARMRESTS (CUSTOM PAD)	SERVICE PART KIT	1
23	AGP02754100	SWITCH- SNAP MTG N.O.	SERVICE PART COMPONENT	1

AGU918013 Transaxle Drive

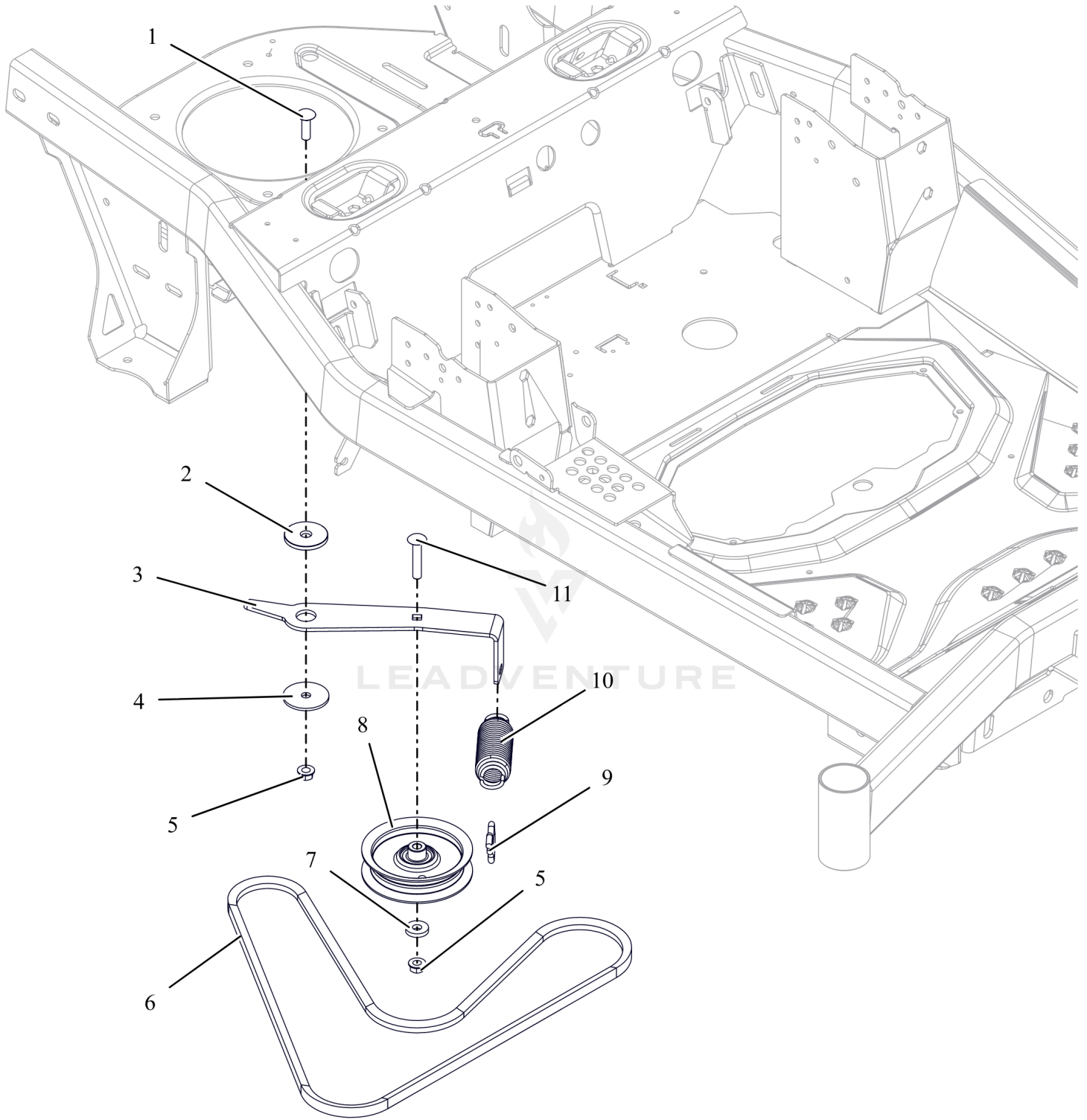

Rendered by LeadVenture, Inc.

AGU918013 Transaxle Drive

Ref Number	Part Number	Part Description	Context Notes	Quantity
1	AGP06200236	BLT,RHSSN .38-16X1.25 G5 ZCC		1
2	AGP05501509	BUSHING FLANGED		1
3	AGP09653351	ARM, GROUND DRIVE IDLER (BLACK)		1
4	AGP06401221	WSHR-FL-STL 0.406X2X0.125 ZCC		1
5	AGP06500901	NUT-LK-CTR-FLG .375-16 GF ZCC		2
6	AGP07200726	V-BELT, HA -RAW EDGED COGGED		1
7	AGP06401108	WSHR, FLT .406X1.00X.188 ZCC		1
8	AGP07350100	IDLER, FLAT - 4.06" X .75"		1
9	AGP09663200	ROD, SPRG BELT TENSIONER		1
10	AGP08300729	SPRG, EXTENSION		1
11	AGP06200323	BLT,RHSSN.375-16X2.00 G5 ZCC		1

AGU918013 Wiring Diagram

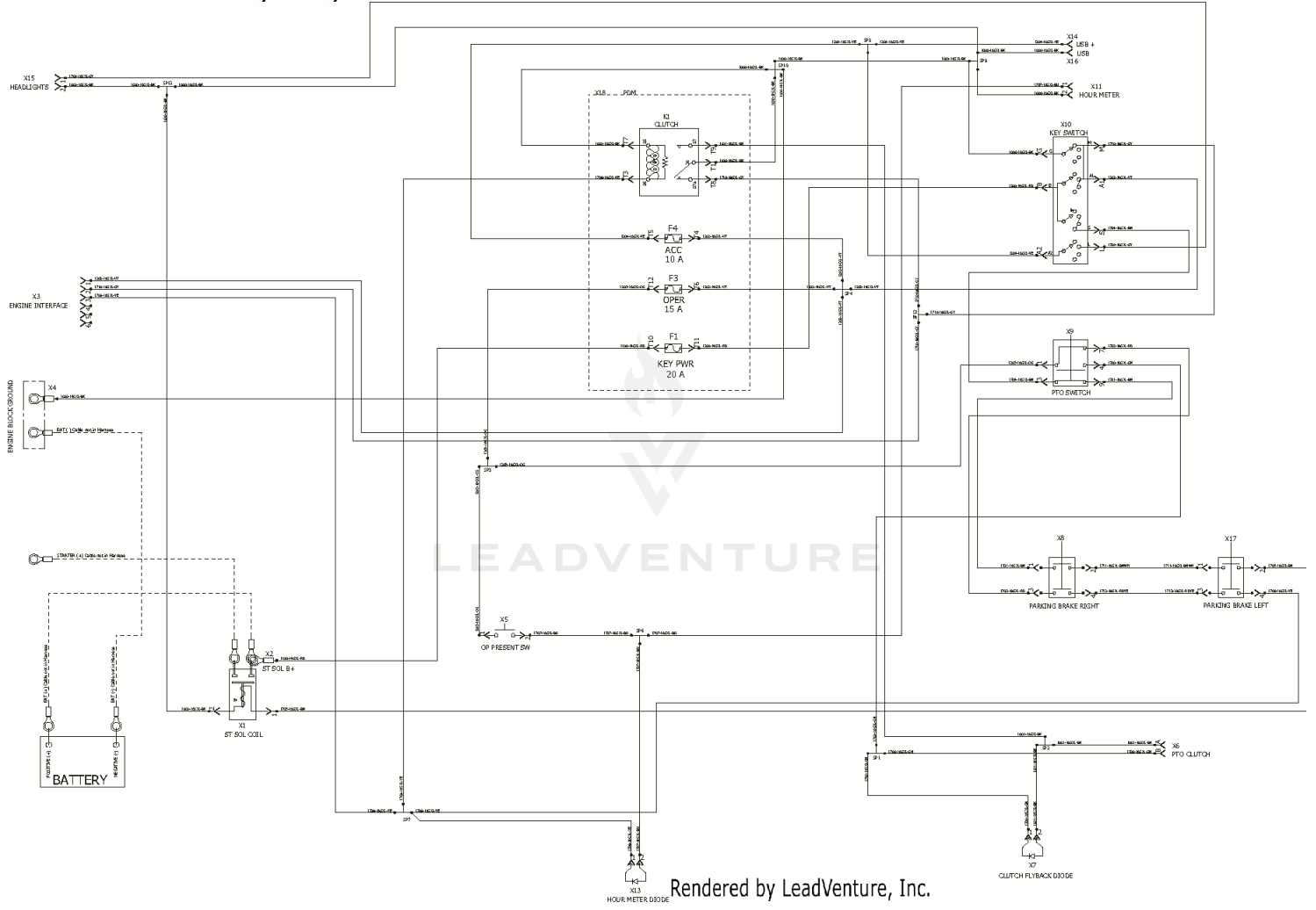

Rendered by LeadVenture, Inc.

AGU918013 Wiring Diagram

Ref Number	Part Number	Part Description	Context Notes	Quantity
-------------------	--------------------	-------------------------	----------------------	-----------------

AGU918013 ZT 2800 Series Transmission - 09483000

ZH-JCBB-ULDB-1MTX

ITEMS NOT SHOWN

3 SEALANT

4 OIL, 20W50

200 SEAL KIT

PARTS INCLUDED IN 200 SEAL KIT :

10, 30, 31, 33, 35, 41, 56, 57, 71, 103,

130, 157

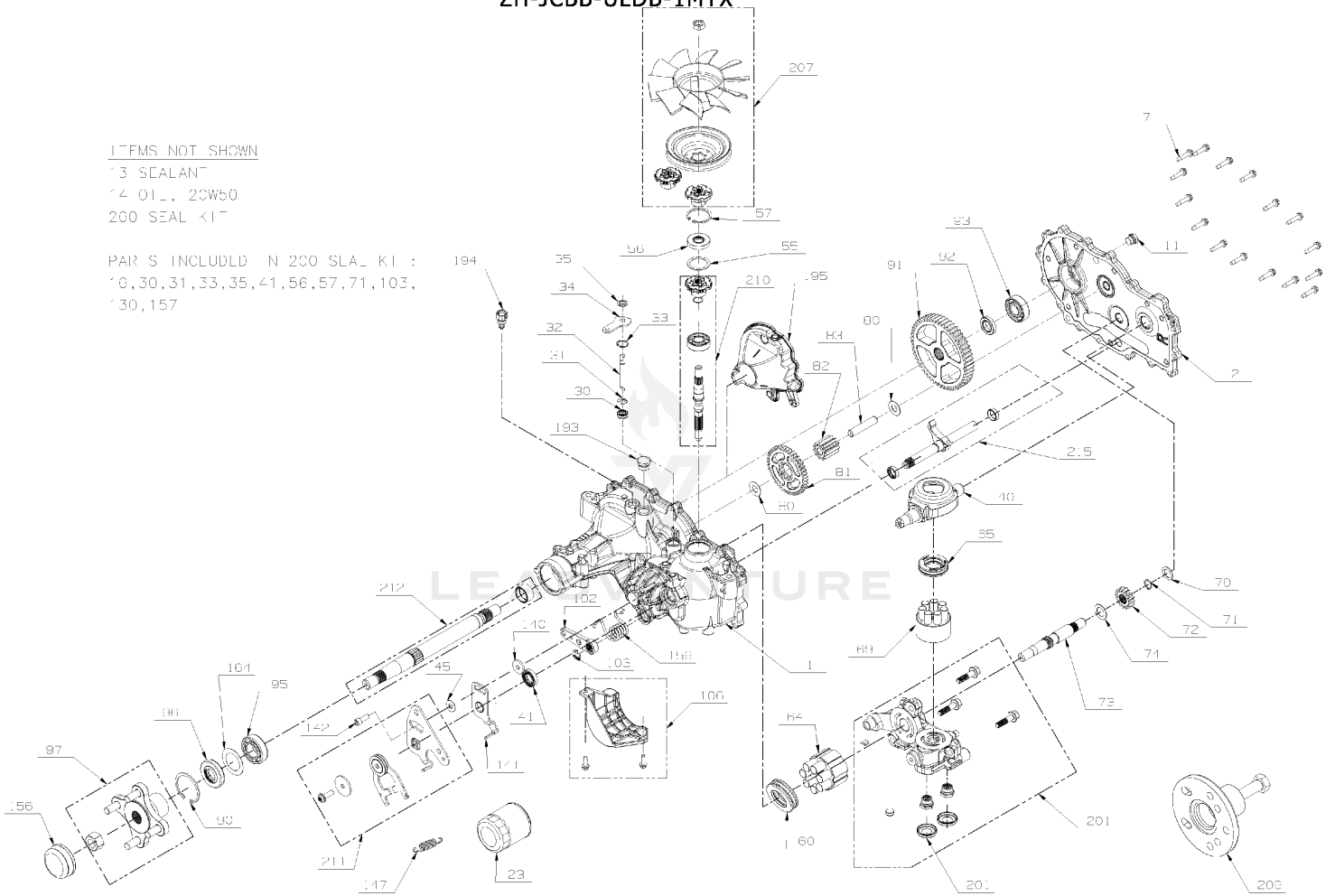

AGU918013 ZT 2800 Series Transmission - 09483000

Ref Number	Part Number	Part Description	Context Notes	Quantity
7	AGP27105900	SCREW,HEX WASHER 1/4-20X1.125		16
11	AGP21500049	PLUG EXT HEX VENT 9/16 18		1
13	AGP21543771	SEALANT TUBE 10.1OZ.		1
14	AGP00057100	FLUID, HYDRO 15W50 QT	RECOMMENDED TRANSMISSION OIL. APPROX. 64 oz	2
14	AGP00058100	FLUID, HYDRO 20W50 QT	OPTIONAL TRANSMISSION OIL. APPROX. 64 Oz	2
23	AGP21544900	FILTER, HYDRO- GEAR 2800 TRANS		1
30	AGP21500013	Seal, lip .375 x 375 x 325	INCLUDED IN ITEM NUMBER 200	1
31	AGP08622500	RING. RETAINING	INCLUDED IN ITEM NUMBER 200	1
33	AGP21543846	RING, RET .750	INCLUDED IN ITEM NUMBER 200	1
34	AGP21543847	ARM, BYPASS		1
35	AGP21543848	RING, RTNG .	INCLUDED IN ITEM NUMBER 200	1
40	AGP21543783	TRUNNION, SWASHPLATE		1
41	AGP21543809	SEAL, LIP 18X32X7	INCLUDED IN ITEM NUMBER 200	1
55	AGP21543773	WASHER 1.23X1.56X.04		1
57	AGP21543741	RING, RET 1.56 INT	INCLUDED IN ITEM NUMBER 200	1
60	AGP21548902	HG THRUST BEARING (51462)		1
64	AGP21548904	HG 16CC CYLINDER BLOCK (71579)		1
65	AGP08609100	BEARING. THRUST 30 X 52 X 13		1
69	AGP21543921	ASSY, BLOCK 7 PISTON		1

Ref Number	Part Number	Part Description	Context Notes	Quantity
74	AGP21543788	WASHER .71 X 1.16 X .04		1
80	AGP21543724	WASHER .5X1.0X.032		2
90	AGP08616500	RING, RETAINING		1
93	AGP21500082	KIT, BEARING		1
95	AGP08614000	BEARING, BALL 25.4 X 52 X 15		1
96	AGP08614300	SEAL, LIP		1
97	AGP21500051	KIT, HUB 4 BOLT		1
102	AGP21500047	HANDLE-ACTUATING		1
103	AGP21544007	CLIP,BRAKE ARM HYDROGEAR 52027	INCLUDED IN ITEM NUMBER 200	1
140	AGP21543870	SPACER		1
141	AGP21543866	ARM, NEUTRAL RIGHT		1
142	AGP21543843	SHCS 5/16-24X1 PATCH		1
147	AGPTCU19204	SPRING, EXTENSION		1
156	AGP21500034	CAP, AXLE		1
159	AGP21544052	SPRING, TORSION CCW		1
200	AGP21543999	KIT, SEAL		1
207	AGP21500024	KIT, FAN / PULLEY		1
209	AGP21544008	HUB PULLER 5 BLT	OPTIONAL SERVICE TOOL	1

AGU918013 ZT 2800 Series Transmission - 09483100

ZH-MCBB-ULDC-1MTX

ITEMS NOT SHOWN

- 13 SEAL ANT
- 14 OIL POW50
- 200 SEAL KIT

PARTS INCLUDED IN 200 SEAL KIT:
10, 30, 31, 33, 35, 41, 56, 57, 71, 103,
130, 157

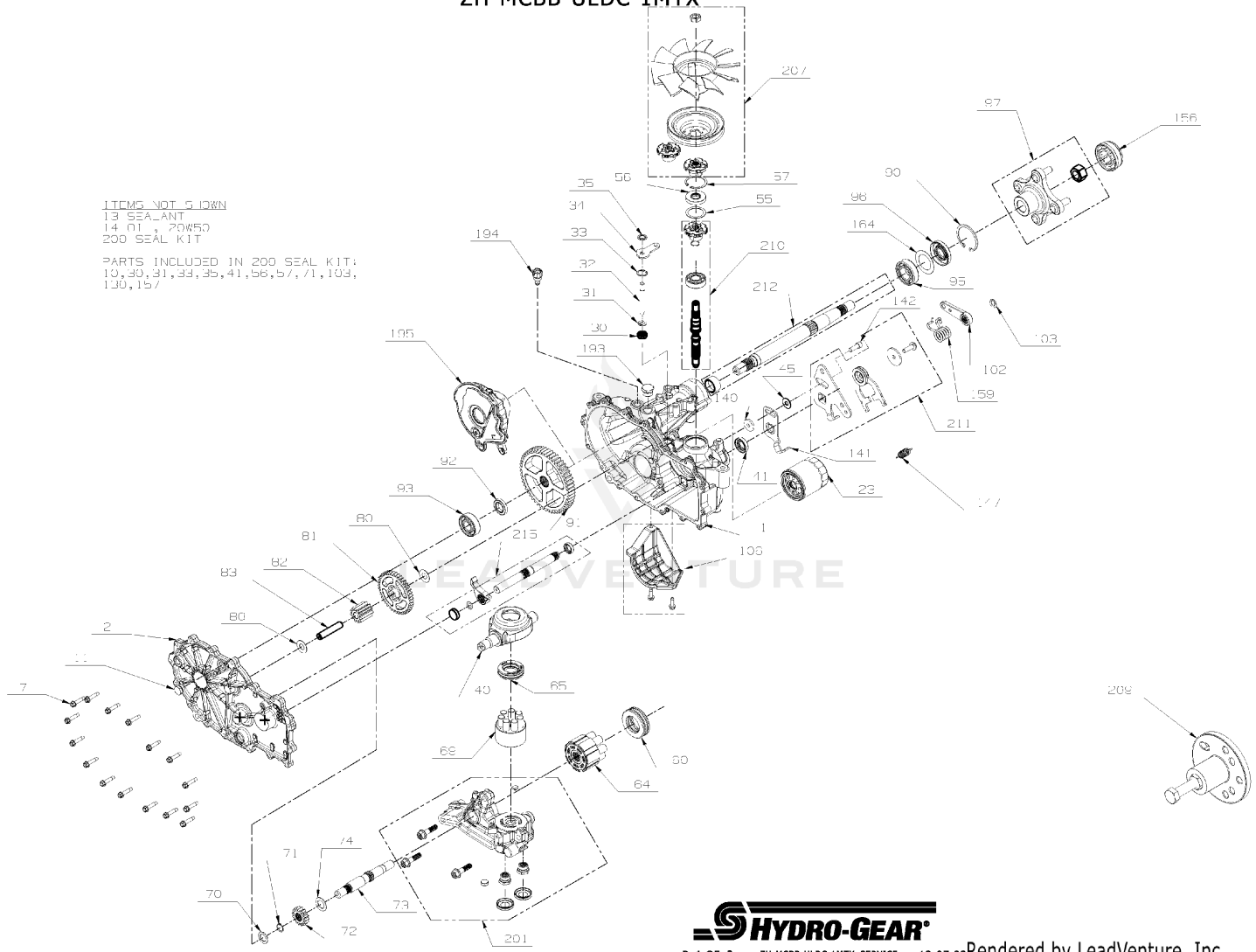

AGU918013 ZT 2800 Series Transmission - 09483100

Ref Number	Part Number	Part Description	Context Notes	Quantity
7	AGP27105900	SCREW,HEX WASHER 1/4-20X1.125		16
11	AGP21500049	PLUG EXT HEX VENT 9/16 18		1
13	AGP21543771	SEALANT TUBE 10.1OZ.		1
14	AGP00057100	FLUID, HYDRO 15W50 QT	RECOMMENDED TRANSMISSION OIL. APPROX. 64 oz	2
14	AGP00058100	FLUID, HYDRO 20W50 QT	OPTIONAL TRANSMISSION OIL. APPROX. 64 Oz	2
23	AGP21544900	FILTER, HYDRO- GEAR 2800 TRANS		1
30	AGP21500013	Seal, lip .375 x 375 x 325		1
31	AGP08622500	RING. RETAINING		1
33	AGP21543846	RING, RET .750		1
34	AGP21543847	ARM, BYPASS		1
35	AGP21543848	RING, RTNG .		1
40	AGP21543783	TRUNNION, SWASHPLATE		1
41	AGP21543809	SEAL, LIP 18X32X7		1
55	AGP21543773	WASHER 1.23X1.56X.04		1
57	AGP21543741	RING, RET 1.56 INT		1
60	AGP21548902	HG THRUST BEARING (51462)		1
64	AGP21548904	HG 16CC CYLINDER BLOCK (71579)		1
65	AGP08609100	BEARING. THRUST 30 X 52 X 13		1
69	AGP21543921	ASSY, BLOCK 7 PISTON		1
80	AGP21543724	WASHER .5X1.0X.032		2
90	AGP08616500	RING, RETAINING		1

Ref Number	Part Number	Part Description	Context Notes	Quantity
93	AGP21500082	KIT, BEARING		1
95	AGP08614000	BEARING, BALL 25.4 X 52 X 15		1
96	AGP08614300	SEAL, LIP		1
97	AGP21500051	KIT, HUB 4 BOLT		1
102	AGP21500047	HANDLE-ACTUATING		1
103	AGP21544007	CLIP,BRAKE ARM HYDROGEAR 52027		1
140	AGP21543870	SPACER		1
141	AGP21543867	ARM, NEUTRAL LEFT		1
142	AGP21543843	SHCS 5/16-24X1 PATCH		1
147	AGPTCU19204	SPRING, EXTENSION		1
156	AGP21500034	CAP, AXLE		1
159	AGP21500036	SPRING, TORSION, CW		1
200	AGP21543999	KIT, SEAL		1
207	AGP21500024	KIT, FAN / PULLEY		1
209	AGP21544008	HUB PULLER 5 BLT	OPTIONAL SERVICE TOOL	1