



TTM98SH Series
TTM108SH Series

RIDE ON



OWNER'S MANUAL



WARNING!

Read this manual carefully before using the machine.



INTRODUCTION

for replacing them in the event of their becoming detached or illegible.

LABEL POSITION

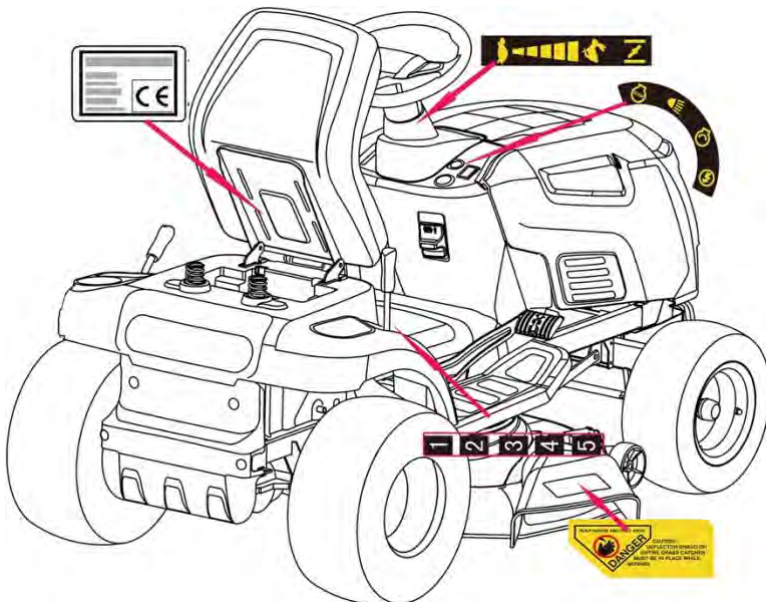
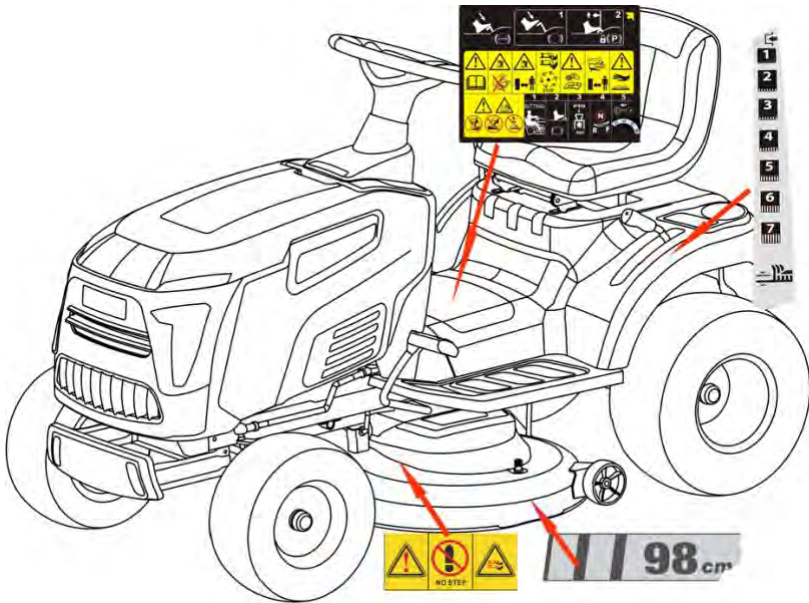

TABLE OF CONTENTS

1. SAFETY.....5

2. IDENTIFICATION OF THE MACHINE AND COMPONENTS.....10

3. UNPACKING AND ASSEMBLY.....13

4. CONTROLS AND INSTRUMENTS.....18

5. HOW TO USE THE MACHINE.....21

 5.1 SAFETY RECOMMENDATIONS.....21

 5.2 WHY THE SAFETY DEVICES CUT IN.....22

 5.3 DIRECTIONS BEFORE STARTING WORK.....22

 5.4 USING THE MACHINE24

 5.5 USING ON SLOPING GROUND25

 5.6 TRANSPORTING.....27

 5.7 LAWN MAINTENANCE27

6. MAINTENANCE.....31

 6.1 SAFETY RECOMMENDATIONS.....31

 6.2 SCHEDULED MAINTENANCE31

 6.3 CHECKS AND ADJUSTMENTS.....32

 6.4 DISMANTLING AND REPLACEMENT33

 6.5 LUBRICATION35

7. TROUBLESHOOTING.....36

8. SPECIFICATIONS.....39

9. WARRANTY.....44

10. CE DECLARATION.....45

1. SAFETY

1.1 HOW TO READ THE MANUAL

Some paragraphs in the manual containing important information regarding safety and operation are emphasized in the following ways.

NOTE or **IMPORTANT** *These give details or further information on what has already been said, in the aim to prevent damage to the machine.*

▲ WARNING! *Non-observance will result in the risk of injury to oneself or others.*

▲ DANGER! *Non-observance will result in the risk of serious injury or death to oneself or others.*

This manual describes various versions of the machine

NOTE *Positions on the machine, such as “front”, “back”, “left” or “right” hand side, refer to the direction of forward travel*

IMPORTANT *For all operations regarding the use and maintenance of the engine not described in this manual, refer to the relevant manuals which form an integral part of all the documentation supplied with the machine.*

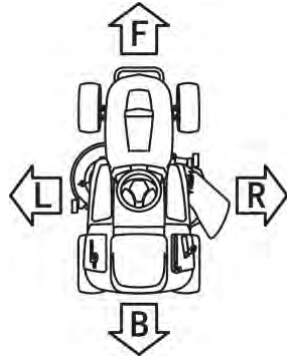

1.2 GENERAL SAFETY REGULATIONS

▲ WARNING! *Read carefully before using the machine.*

A) TRAINING

1) Read the instructions carefully. Be familiar with the controls and how to use the equipment properly.

2) Never let children or people unfamiliar with these instructions use the machine. Local regulations can restrict the age of the user.

3) Never mow while people, especially children, or pets nearby; Never mow while dark.

4) Keep in mind that the operator or user is responsible for accidents or hazards occurring to other people or their property.

5) Do not carry passengers.

6) All drivers should seek and obtain professional and practical instruction. Such instruction should emphasize:



SAFETY

- the need for care and concentration when working with ride-on machines;
- you can not use the brake to regain control of a ride-on machine sliding down a slope.

The main reasons for loss of control are:

- insufficient wheel grip;
- over-speeding;
- inadequate braking;
- the type of machine is unsuitable for its task;
- unawareness of the effect of ground conditions, especially slopes;
- incorrect hitching and load distribution

B) PREPARATION



1) While mowing, always wear sturdy footwear and long trousers.

Do not operate the equipment barefoot or wearing open sandals.

2) Thoroughly inspect the area where the equipment is to be used

and remove all objects which can be ejected from the machine.



3) DANGER! Petrol is highly flammable:

– store fuel in containers specifically designed for this purpose;

– refuel outdoors only and do not smoke while refueling;

– add fuel before starting the engine. Never remove the cap of the fuel tank



or add petrol while the engine is running or when the engine is hot;

– if you spill petrol, do not start the engine and move the machine away from the area of spillage. Do not create any source of ignition until the petrol vapours

have evaporated;

– put back and tighten all fuel tank and container caps securely.

4) Replace faulty silencers.

5) Before use, always inspect the machine to check that the blades, blade bolts and cutter assembly are not worn or damaged. Replace worn or damaged blades and bolts in sets to preserve balance.

6) On multi-bladed machines, remember that the rotation of one blade can cause other blades to rotate



C) OPERATION

1) Do not start the engine in a confined space where dangerous carbon monoxide fumes can collect.

2) Mow only in daylight or good artificial light.

SAFETY

- 3) Before starting the engine, disengage the blades and shift into neutral.
- 4) Do not use the machine on slopes with longitudinal gradients of more than 15°(27%); do not use the machine on slopes with lateral gradients above 10°(18%).
- 5) Remember there is no such thing as a “safe” slope. Travelling on grass slopes requires particular care. To guard against overturning:
 - do not stop or start suddenly when going up or downhill;
 - engage the drive slowly and always keep the machine in gear, especially when travelling downhill;
 - machine speeds should be kept low on slopes and during tight turns;
 - stay alert for humps and hollows and other hidden hazards;
 - never mow across the face of the slope.
- 6) Use care when pulling loads or using heavy equipment:
 - use only approved drawbar hitch points;
 - limit loads to those you can safely control;
 - do not turn sharply. Use care when reversing;
 - use counterweight(s) or wheel weights whenever advised in the instructions manual.
- 7) Stop the blades before crossing surfaces other than grass.
- 8) Never use the machine with damaged guards, or without the safety protective devices in place.
- 9) Do not change the engine governor settings or overspeed the engine. Operating the engine at excessive speed can increase the risk of personal injury.
- 10) Before leaving the driving seat:
 - disengage the blades and lower the attachments;
 - go into neutral and apply the parking brake;
 - stop the engine and remove the ignition key.
- 11) Disengage the blades, stop the engine and remove the ignition key:
 - before clearing blockages or unclogging the collector channel;
 - before cleaning, checking or servicing the machine;
 - after striking a foreign object. Inspect the machine for damage and make repairs before restarting and operating the machine;
 - If the machine starts to vibrate abnormally (check for the causes immediately).
- 12) Disengage the blades for transport or whenever they are not in use.
- 13) Stop the engine and disengage the blades:
 - before refueling;
 - before making height adjustment unless adjustment can be made from the operator’s position.
- 14) Reduce the throttle during engine run-out. If the engine is provided with a shut-off

SAFETY

valve, cut off the fuel when you have finished mowing.

15) Watch out for traffic when crossing or near roadways.

16) Never direct discharge of material toward bystanders nor allow anyone near the machine while in operation.

D) MAINTENANCE AND STORAGE

1) Keep all nuts, bolts and screws tight to be sure the equipment is in safe working condition.

2) Never store the equipment with petrol in the tank inside a building where fumes may reach an open flame or spark.

3) Allow the engine to cool before storing in any enclosure.

4) To reduce fire hazards, keep the engine, silencer, battery compartment and petrol storage area free of grass, leaves, or excessive grease.

5) Check the grass-catcher frequently for wear or deterioration.

6) Replace worn or damaged parts for safety purposes.

7) If the fuel tank has to be drained, this should be done outdoors.

8) On multi-bladed machines, remember that the rotation of one blade can cause other blades to rotate.

9) When the machine is to be parked, stored or left unattended, lower the cutting means unless a positive mechanical lock is used.

1.3 SAFETY LABELS

Your machine must be used with care. This is why labels with illustrations have been placed on the machine, to remind you of the main precautions to take during use.

These labels are to be considered an integral part of the machine.

Should a label come off or become illegible, contact your dealer to replace it. Their meaning is explained below.



Warning:

Read the instructions before operating this machine.



Danger!

Risk of injury.

Blades in movement.
The blades will continue turning for some time after switching off the engine or disabling the blade control.



Warning:

Disconnect the ignition key and read the instructions before carrying out any repair or maintenance work.



Warning:

Do not step on the deck or discharge guard.



Warning: Do Not Step.



Danger!

Ejected objects:

Do not operate without the discharge guard or grass-catcher in place.



Danger!

Ejected objects:

Warning: Keep bystanders away.



Danger!

Dismemberment:

Make sure that children stay clear of the machine at all times while the engine is running.



Warning!

Never use pressure lances to wash the transmission system.



Danger!

Risk of burns

Wait for the engine to completely cool down before making any adjustments or servicing the engine itself.



Warning:

KEEP HAND AND FEET AWAY FROM THE BLADES

Danger!

Risk of serious injury.

Keep hands and feet away until the blades and all moving parts come to a halt.



Danger!

Risk of overturning on steep gradients

WARNING! Do not use the machine on slopes with longitudinal gradients greater than 15°(27%).

Do not use the machine on slopes on slopes with lateral gradients greater than 10°(18%).

1.4 REGULATIONS FOR TOWING

A kit for towing a small trailer is available on request, this accessory is to be fitted following the instructions provided, when using the towing kit. Do not exceed the recommended loads stated on the label and follow the safety instructions.

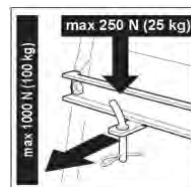

2. IDENTIFICATION OF THE MACHINE AND COMPONENTS

2.1 IDENTIFICATION OF THE MACHINE

The label located in the seat bracket has the essential data of each machine

1. Name and address of manufacturer.
2. Designation of the machine
3. Type of machine
4. Cutting width
5. Mass of machine
6. Nominal power of engine
7. Serial number
8. Year of manufacture
9. Acoustic power level according to directive 2000/14/CE
10. Conformity mark according to directive 2006/42/EC

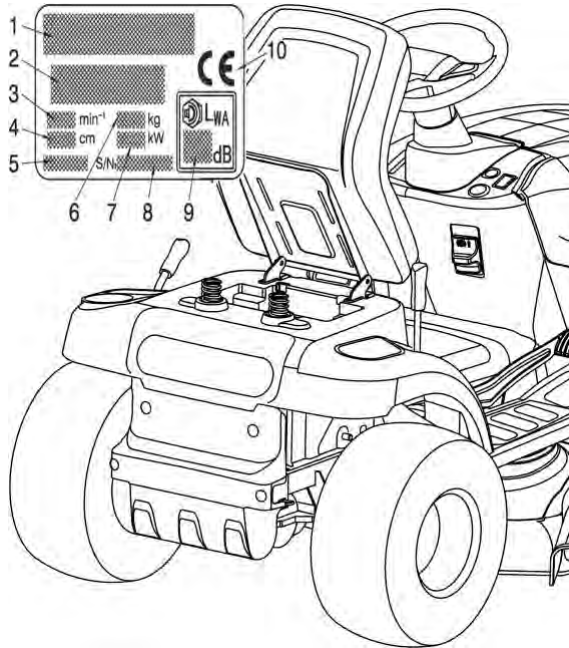

2.2 IDENTIFICATION OF MAIN COMPONENTS

The main components of the machine as following:

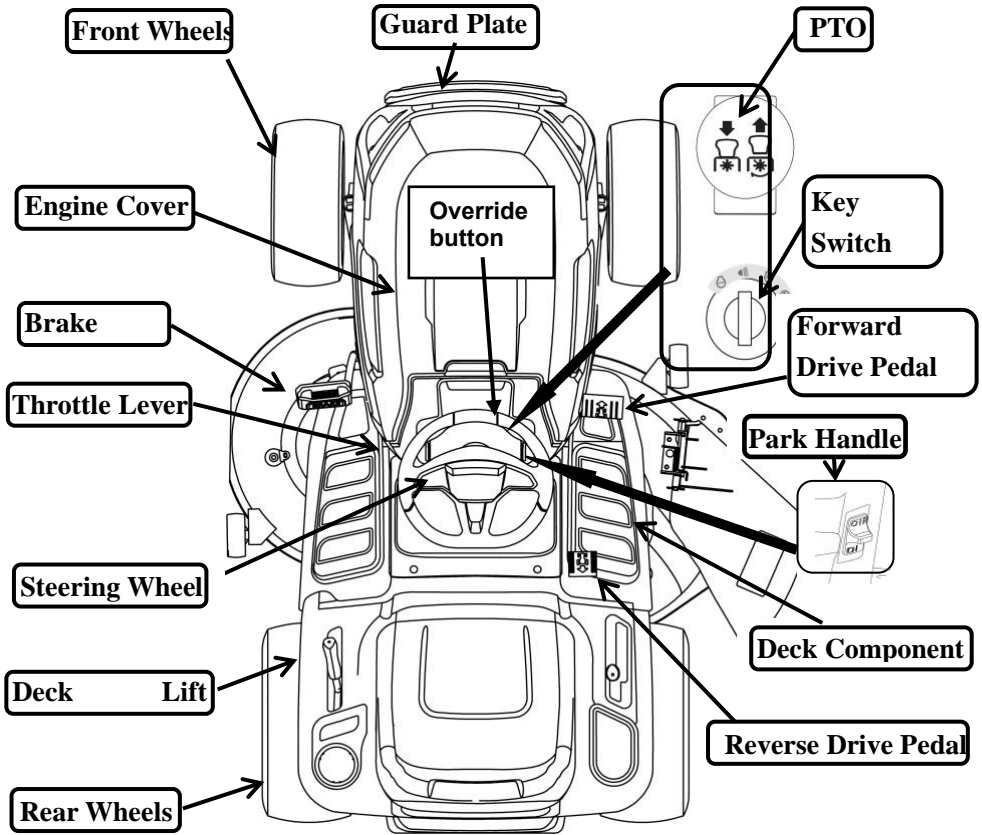

3. UNPACKING AND ASSEMBLY

For storage and transport purposes, some components of the machine are not installed in the factory and must be assembled after unpacking. Follow the instructions below.

IMPORTANT

The machine is supplied without engine oil or fuel. Before starting the engine, fill it with oil and fuel following the instructions given in the engine manual.

3.1 UNPACKING

When unpacking the machine, take care to gather all individual parts and fittings, and do not damage the cutting deck when taking the machine off the pallet.

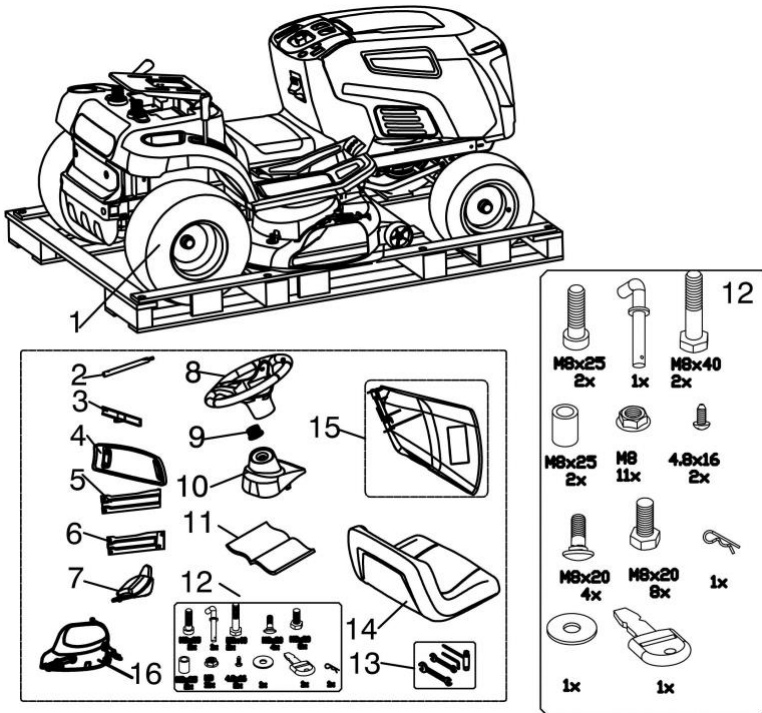

- 1. machine body
- 2. Steering connect shaft
- 3. Towing kit
- 4. Bumper
- 5. Bumper bracket L
- 6. Bumper bracket R
- 7. Steering wheel cover
- 8. Steering wheel
- 9. Splined hub
- 10. Steering shaft cover
- 11. instruction manual
- 12. Nuts, bolts, washer,
- bushing and starter key
- 13. Tools
- 14. Seat
- 15. Side deflector
- 16. Mulching kit

NOTE

To prevent damage to the cutting deck, raise it to its maximum height and take utmost care when taking the machine off the pallet.

3.2 FITTING THE STEERING WHEEL

Put the machine on a flat surface and straighten up the front wheels.

a. Fit the shaft (1) onto the couplings and tightening the screw M8x25 (2). (Use the hex wrench 5 in accessories tools.)

b. Fit the steering shaft cover (3).

c. Inset the splined hub (4) to shaft (1), mounting steering wheel (5), spacer (6) and tightening nut M8 (7). (Use the open end wrench 13-15 in accessories tools.)

d. Inset the steering wheel cover (8) into steering wheel and tightening two screws ST4.8x16 (9). (Use the cross screwdriver in accessories tools.)

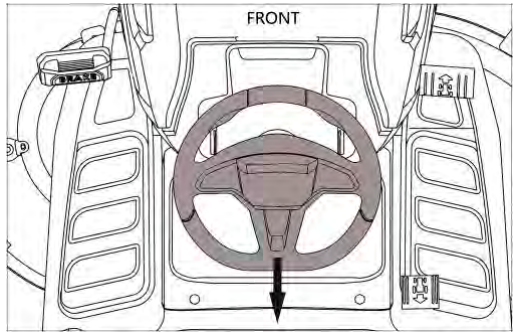
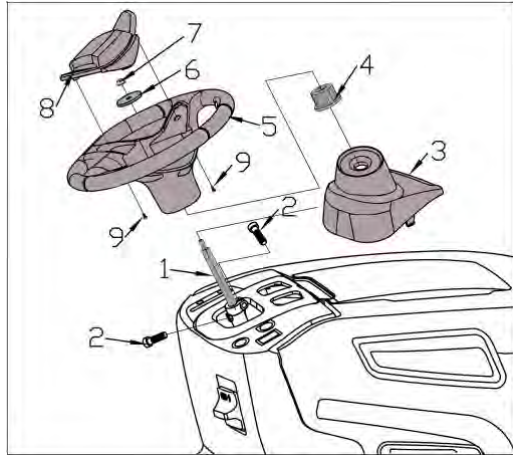

NOTE

Pay attention to the direction when mounting the steering wheel.

3.3 FITTING THE SEAT

Mount the seat on the plate using the 4pcs M8x20 screws. (Use the open end wrench 8-10 in accessories tools.)

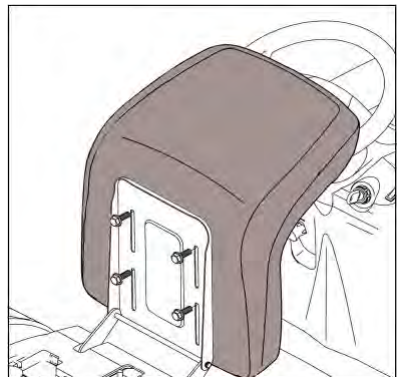

3.4 CONNECTING THE BATTERY



The electrolytic fluid is a solution of sulphuric acid.

Danger: Sulphuric acid is poisonous



Danger: Sulphuric acid is corrosive Sulphuric acid can cause blindness or severe burns.



Danger: Keep out of reach of children.



The owner of the electrical equipment must make sure that the equipment is properly disposed of if he no longer wants to keep the equipment. The old equipment can be returned to a suitable collection point that will dispose of the equipment in accordance with the national recycling and waste disposal regulations. This does not apply to any accessories or aids without electrical components supplied with the old equipment.

The reprinting or reproduction by any other means, in whole or in part, of documentation and papers accompanying products is permitted only with the express consent of Masport Ltd.



1) Fit the battery in its housing.

IMPORTANT

Position the battery with the polarities (+) and (—)

2) Connect the battery connectors to the machine connection leads and tighten the 2 screws. then cover the protective cap for the 2 wire is in place.(Use the open end wrench 8-10 and cross screwdriver in accessories tools)

3) Secure the battery with the small rubber strap.

NOTE

This machine used the battery: **12 V**  **18Ah.**
The battery is fully charged before leaving the factory. If the battery is found to be insufficient, please use a 12V1A charger to charge the battery

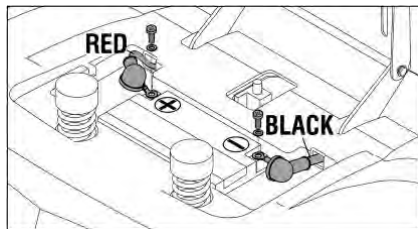

3.5 MOUNTING THE FRONT BUMPER

a. Mounting the bumper bracket L and bumper bracket R on the bumper, using 4pcs M8 nuts and 4pcs M8x20 screws. (Use the open end wrench 13-15 in accessories tools.)

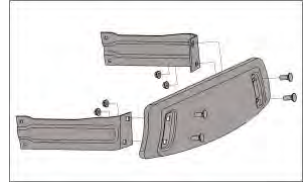

b. Mounting the front bumper on the bottom of the frame using the 4pcs M8 nuts and 4pcs M8x20 biots. (Use the open end wrench 13-15 in accessories tools.)

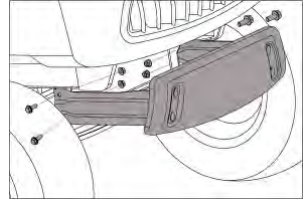

3.6 MOUNTING THE SIDE DEFLECTOR

a. Insert the elastic pin (1) and washer (2) into the right end of the pin (3);

b. Insert the pin shaft into the side deflector (4), bracket (6) and torsion spring (5) in sequence, and insert the washer (2) and elastic latch (1) at the other end.

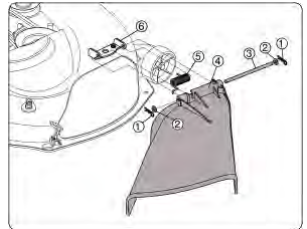

Note: When you need to open the side deflector, please press the self-locking button first, and do not force it to open.

3.7 MOUNTING THE MULCHING KIT

If you decide to mow the grass, mulching it and leaving it on the grass, a "mulching" kit is included with the machine. This must be assembled on the cutting deck as indicated in the bellows,

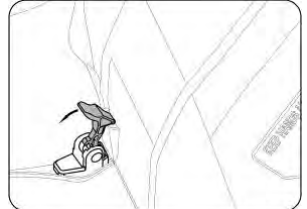

- Press the self-locking button to open the side deflector;
- Pass the lug boss (M) on the mulching kit through the bottom of the pin (N), insert the lower left corner of the mulching kit into the space under the self-locking parts base (Figure B), and insert the right dowel pin into the hole of deck (Figure C);

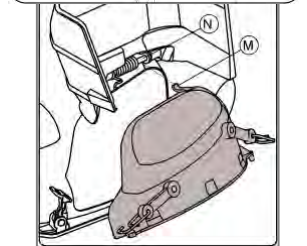

- Hang the left hook into the groove on the base of the self-locking parts (Figure A), and the right hook into the hole of the deck (Figure D).

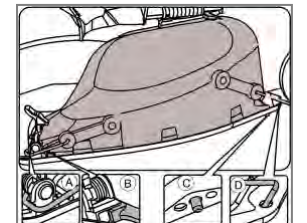

3.8 MOUNTING THE TOWING KIT

- a. Remove the tension arm bushing (2), the hexagonal flange bolts M8×20 (3), and the hexagonal flange locking nuts M8 (1) that secured the gearbox cover (4);

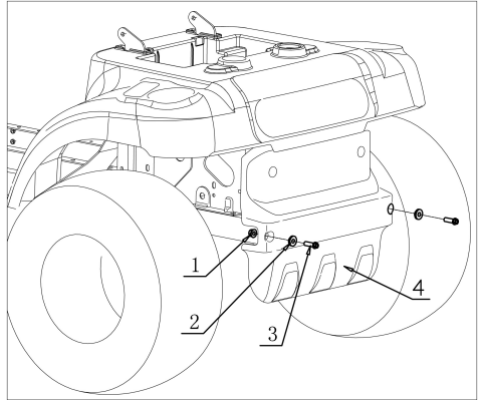

- b. Insert the bushing (2) into the two holes where the bolts were just removed, align the towing plate (5), and then install the hexagonal flange bolts M8×40 (3), hexagonal flange locking nut M8 (1), and then tighten the bolt.

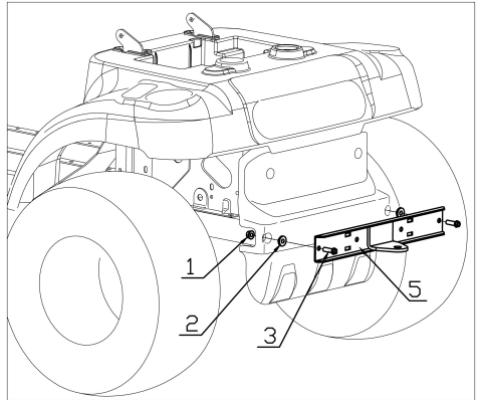

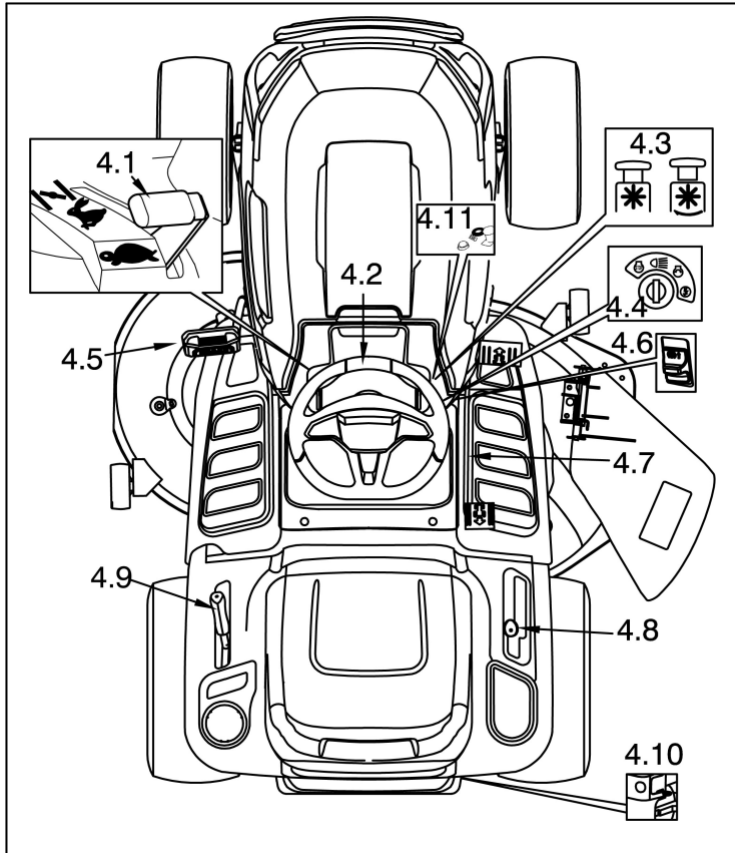

4. CONTROLS AND INSTRUMENTS



4.1 THROTTLE LEVER

This regulates the engine revs, The positions are indicated on a label showing the following symbols:

-  «CHOKE» cold starting
-  «SLOW» for minimum engine speed
-  «FAST» for maximum engine speed

- The «CHOKE» position enriches the mixture so must only be used for the time necessary when starting from cold.
- When moving from one area to another, put the lever in a position between «SLOW» and «FAST».
- When cutting, shift into «FAST».

4.2 STEERING WHEEL

Turns the front wheels.

4.3 BLADE START/STOP KNOB

The blade start/stop knob is located on the RH console in front of the key switch.

The blade start/stop knob operates the electric clutch. Pull the knob upward to engage the blades. Push the knob downward to disengage the blades.

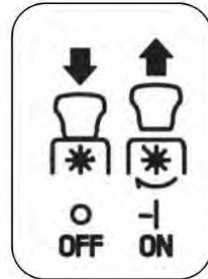

4.4 KEY IGNITION SWITCH

This key operated control has four positions:



«OFF» everything is switched off.



«ON» activates all parts.



«START» connects the starter Motor. If you release the key on «START», it will automatically return to «ON».



The key sends power to the headlights when the switch is in the position.

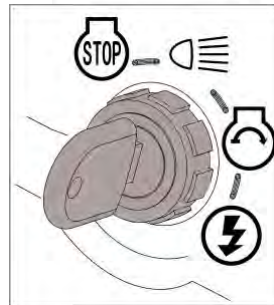

4.5 Brake Pedal

The brake pedal is located on the left front side of the board. The brake pedal can be used for sudden stops or **setting the parking brake**.

NOTE

When the machine is moving, keep your foot off the pedal.



4.6 PARKING BRAKE LEVER

With machine stopped:

- 1) Keep the pedal pressed;
- 2) Lift the parking brake lever and keep lifted;
- 3) Release the pedal.



This way, the rear wheels remain braked. To release the parking brake, fully press the pedal (the parking

brake lever is automatically released and returns to down position).

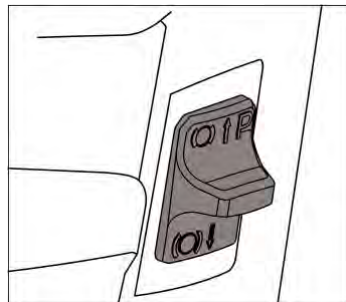

NOTE

The engine can only be started at the parking position. Sitting on the machine with either the parking brake lifted or brake pedal pressed.

4.7 DRIVE ENGAGEMENT

(for hydrostatic transmission model)

This pedal engages drive in the wheels as well as modulating the machine's forward and reverse speeds.

—To engage forward drive, press it towards «F» with your toecap. As you increase the pressure on the pedal, the speed of the machine increases.

—Reverse is engaged by pressing the pedal with the heel towards «R».

—The pedal automatically goes into neutral «N» when released.

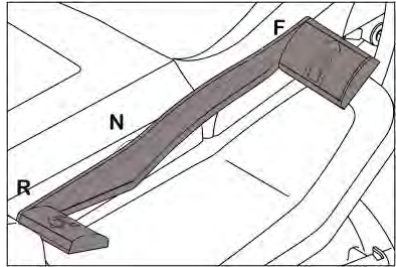

▲ WARNING!

Reverse must only be engaged when the machine is stopped.

Make sure the parking brake has been released before driving the mower.

NOTE

4.8 CUTTING HEIGHT ADJUSTMENT LEVER



Lifts or lowers the blade deck and thereby adjusts the grass cutting height.

There are seven positions for this lever (shown as «1» to «7» on the label), which correspond to various heights between 30 and 90 mm.

4.9 SEE DESCRIPTION IN 5.3.3

4.10 Reverse Mode Operation Button (RMO)

The reverse mode operation knob is located on the RH console to the left of the blade start/stop knob. The blades will stop when traveling in reverse. To keep the blades rotating when traveling reverse, press and hold the RMO button.

NOTE: In most cases, mowing in reverse is not recommended.

5. HOW TO USE THE MACHINE

5.1 SAFETY RECOMMENDATIONS

▲ DANGER!

The machine must only be used for the purpose for which it was designed (cutting grass).

Do not tamper with or remove the safety devices fitted on the machine.

REMEMBER THAT THE USER IS ALWAYS RESPONSIBLE FOR DAMAGE AND INJURY TO OTHERS. *Before using the machine:*

– *read the general safety regulations, paying particular attention to driving and cutting on slopes;*

– *carefully read the instructions for use, make sure you are familiar with the controls and know how to stop the blades and the engine quickly;*

– *never put your hands or feet next to or beneath the rotating parts and always keep away from the exit.*

Do not use the machine when in a precarious state of health or under the effect of medicine or any other substances that can reduce your reflex actions and your ability to concentrate. It is the user's responsibility to assess the potential risk of the area where work is to be carried out, and to take all the necessary precautions to ensure his own safety and that of others, particularly on slopes or rough, slippery and unstable ground.

Do not leave the machine on high grass with the engine running to avoid the risk of starting a fire.

Do not use the machine without the side deflector in place.

▲ WARNING!

Do not use the machine on lawns with gradients of more than 15° (27%). Do not use the machine on lawns with side gradients above 10° (18%). If the machine is likely to be used mostly on sloping ground fit counterweights beneath the cross-member of the front wheels. These improve stability at the front and reduce the chances of tipping over.

IMPORTANT

All the references relating to the positions of controls are described in chapter 4.

5.2 WHY THE SAFETY DEVICES CUT IN

The safety devices work in two ways:

- they prevent the engine from starting if all the safety requirements have not been met;
- they stop the engine if even just one of the safety requirements is lacking.

a) To start the engine, it is necessary that:

- the blades are not engaged;
- the parking brake is engaged and the transmission is disengaged;
- the operator sits on the seat;

b) The engine stops when:

- the operator leaves his seat while mowing or driving;

5.3 DIRECTIONS BEFORE STARTING WORK

Before starting to mow, it is necessary to carry out several checks and operations to ensure you can work efficiently and in maximum safety.

5.3.1 Seat adjustment

To change the seat position, loosen the four fixing bolts and slide it along the slots.

Once you have found the right position, tighten the four screws.

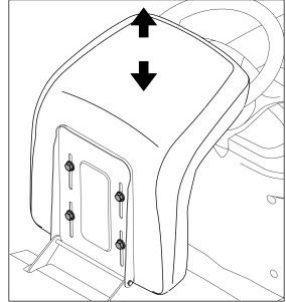

5.3.2 Tyre pressure

Having the correct tyre pressure is important for ensuring that the cutting deck is horizontal and mows evenly.

Unscrew the valve caps and connect a compressed air line with a gauge to the valves.

The pressures are:

FRONT 1.0 bar (15 x 6.0-6)

REAR 1.2 bar (18 x 8.5-8)

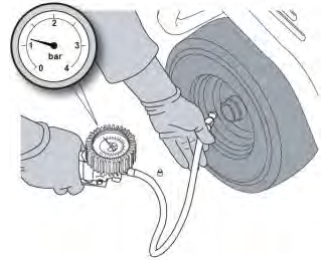

5.3.3 Checking the fuel and oil

NOTE

The engine manual indicates what type of oil and fuel you can use.

With the engine off, check the oil level. According to the instructions in the engine manual, this must be between the MIN and MAX marks on the dipstick.

Refuel using a funnel, but do not completely fill the tank. The tank's capacity is about 7.5 litres.

⚠ DANGER!

Refuelling should be carried out in an open or well-ventilated area with the engine off.

Always remember that petrol fumes are inflammable.

DO NOT USE A NAKED FLAME TO LOOK INSIDE THE TANK AND DO NOT SMOKE WHEN REFUELLING

IMPORTANT

Do not drip petrol onto the plastic parts to avoid damaging them. In the event of accidental spills or leaks, rinse immediately with water. The warranty does not cover for damage to plastic parts of the bodywork or the engine caused by petrol.

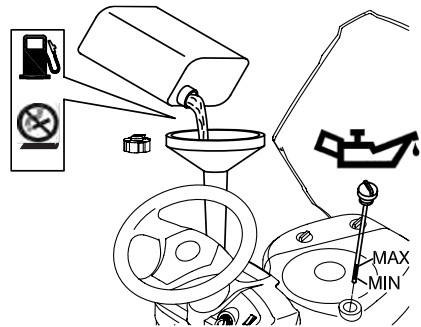

5.3.4 Checking machine safety and efficiency

1. Check that the safety devices function as described. (see 5.2)
2. Check that the brake is in perfect working order.
3. Do not start mowing if the blades vibrate or if you are unsure whether they are sharp enough. Always remember that:
 - A badly sharpened blade pulls at the grass and causes the lawn to turn yellow.
 - A loose blade causes unwanted vibrations and can be dangerous.

▲ WARNING!

Do not use the machine if you are unsure whether it is working safely or efficiently. If in doubt, contact your Dealer immediately to make the necessary checks and repairs.

5.3.5 Hydrostatic transmission disengagement lever

This lever has two positions as shown on the label:

- «A» = Transmission engaged: for all uses, when moving and during cutting;
«B» = Transmission disengaged: this makes it much easier to move the machine by hand, with the engine stopping.

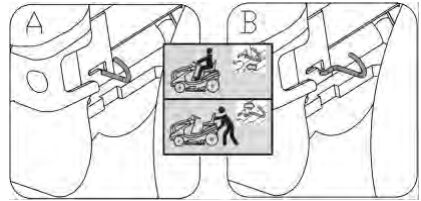

5.4 USING THE MACHINE

5.4.1 Starting

▲ DANGER!

The engine must be started in an open or well-ventilated area!
ALWAYS REMEMBER THAT EXHAUST GASES ARE TOXIC!

To start the engine:

- open the fuel stopcock (to “I”);
- close the engine cover;
- lift the cutting deck raised as high as possible.
- disengage the blades;
- shift the gear lever to neutral;
- operate the parking brake;
- when starting from cold, move the throttle to the «CHOKE» position shown on the label;
- if the engine is already warm, position the lever between «SLOW» and «FAST»;
- put in the ignition key and turn to «ON» to make electrical contact, then turn to «START» to start the engine;
- release the key once the engine has started.

When the engine has started, move the throttle to «SLOW».

IMPORTANT

The choke must be opened as soon as the engine is running smoothly. Using it when the engine is already warm can foul the spark plugs and cause the engine to run erratically.

NOTE

If there are engine starting problems, do not persist as you can risk

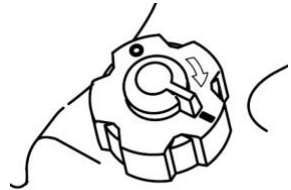

running the battery flat and flooding the engine. Turn the key to «OFF», wait for a few seconds and then repeat the operation. If the malfunction persists, refer to the engine manual.

IMPORTANT

Always bear in mind that the safety devices prevent the engine from starting if safety requirements have not been met. In these cases, once the situation has been corrected, the key must first be turned back to «OFF» before the engine can be restarted.

5.4.2 Starting and moving without mowing

▲ WARNING!

This machine has not been approved for use on public roads. It has to be used (as indicated by the highway code) in private areas closed to traffic.

When moving the machine, the blades must be disengaged and the cutting deck raised as high as possible. (position «7»)

Position the throttle between «SLOW» and «FAST»

Keep the brake pedal pressed down and release the parking brake, release the brake pedal slowly to start forward movement of the machine.

▲ WARNING!

The brake pedal has to be released gradually as a sudden engagement may cause the machine to tip over and the driver to lose control.

Gradually reach the desired speed using the throttle

5.4.3 Braking

First slows down the machine by reducing the engine speed, and then push the brake pedal right down to lower the speed even more until the machine stops.

5.4.4 Reverse

IMPORTANT

Reverse must be engaged only when the machine has stopped completely.

When the machine is stopped, start the reverse movement by pressing the drive engagement pedal in the «R» direction.

5.4.5 Grass cutting

To start cutting:

- move the throttle to «FAST»;
- raise the cutting deck as high as possible;
- engage the blades;
- start moving forwards on the grass very slowly and with utmost caution, as already described;
- regulate the cutting height and speed considering the conditions of the lawn. (the height, density and dampness of the grass).

▲ WARNING!

When cutting on sloping ground, reduce your speed to ensure safe conditions.

Whatever the conditions, always reduce the speed if you notice a drop in engine speed – if you travel too fast compared to the amount of grass being cut, you will not be able to mow the grass well.

Disengage the blades and raise the cutting deck as high as possible whenever you need to get past an obstacle.

IMPORTANT *This machine has not been approved for mowing when it going reverse. The blades will stop when the machine go reverse by press the drive pedal towards «R». Press the override button (right of the steering wheel) can keep the blades rotating when the mower moving reverse.*

5.4.6 End of mowing

When you have finished mowing, disengage the blades, lower the engine speed and ride the machine with the cutting deck raised as high as possible.

5.4.7 End of work

Stop the machine, move the throttle to «SLOW» and turn off the engine by turning the key to «OFF».

When the engine has stopped, close the fuel stopcock.

▲ WARNING! *To avoid backfire, position the throttle on «SLOW» for 20 seconds before stopping the engine.*

▲ WARNING! *Always take out the ignition key before leaving the machine unattended!*

IMPORTANT *To keep the battery charged, do not leave the key in the «ON» position when the engine is not running.*

5.4.8 Cleaning the machine

After use, clean the outside of the machine, empty the discharge chute, and shake it to remove grass and other debris.

Clean the plastic parts of the body with a damp sponge using water and detergent, taking care not to wet the engine, the electrical parts or the electronic circuit board located under the dashboard.

IMPORTANT *Never use hose nozzles or harsh detergents to clean the bodywork or the engine!*

When washing the inside of the cutting deck, the machine must be on firm ground with:

- the discharge chute fitted;
- the operator seated;
- the engine running;
- the transmission in neutral;
- the blades engaged.

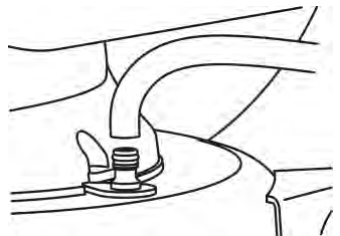

Connect a water hose to each of the pipe fittings one at a time and run water through each one for a few minutes, with the blades moving.

When washing, the cutting deck should be lowered right down.

5.4.9 Storage and inactivity for long periods

If you intend not to use the machine for a long period (more than 1 month), disconnect the battery cables and follow the instructions in the engine instruction manual.

Empty the fuel tank by disconnecting the tube situated at the inlet of the fuel filter and follow the instructions in the engine manual.

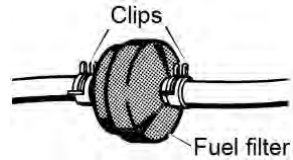

▲ WARNING!

Carefully remove any dry grass cuttings which may have collected around the engine or silencer to prevent their catching fire the next time the machine is used!

Put the machine away in a dry, sheltered place and preferably covered with a cloth.

IMPORTANT

The battery must be kept in a cool and dry place. Before a long storage period (more than 1 month), always charge the battery, and then recharge before using again.

The next time the machine is used, check that there are no fuel leaks from the tubes, fuel stopcock or carburetor.

5.4.10 Card protection device

The electronic circuit board has a self-resetting protector which breaks the circuit if there is a fault in the electrical system. It results in the stopping of the engine and the switching off the lamp.

The circuit automatically resets after a few seconds, but the cause of the fault should be ascertained and dealt with to avoid reactivating the protection device

IMPORTANT

To avoid activating the protection device:

- do not invert the leads on the battery terminals;***
- do not use the machine without its battery or damage may be caused to the charging regulator;***
- be careful not to cause short-circuits.***

5.4.11 Summary of main steps to follow when using the machine

To...	You must...
Start the engine	Open the fuel stopcock, ensure that all the conditions allowing starting are met, and then turn the key.
Go forward	push the pedal right down, engage the gear and then gradually release the pedal.
Brake or stop	Reduce the engine speed and press the brake pedal.
Reverse	Stop the machine; put into neutral, push the brake pedal right down, engage reverse, and then gradually release the brake pedal.
Cut the grass	Fit the discharge chute; apply the throttle; engage the blades; adjust the cutting height, push the pedal right down, engage the gear and then gradually release the pedal.
Finish mowing	Disengage the blades and reduce the engine speed.
Stop the engine	Reduce the engine speed, wait a few seconds, turn the key and close the fuel stopcock.
Store the machine	Engage the parking brake, remove the key and, if necessary, wash the machine, the inside of the cutting deck.

5.5 USING ON SLOPING GROUND

Only mow on slopes with gradients up to the maximum already mentioned.

Lawns on a slope must be mowed moving up and down and never across them. When changing direction, take great care that the wheels facing up the slope do not hit any obstacles (such as stones, branches, roots, etc.) that may cause the machine to slide sideways, tip over or make you lose control.



▲ DANGER! *REDUCE SPEED BEFORE ANY CHANGE OF DIRECTION ON SLOPES, and always apply the parking brake before leaving the machine at a*

standstill and unattended.

▲ WARNING!

Start moving forwards very carefully on sloping ground to prevent the risk of tipping over. Reduce the forward speed before going on a slope, particularly downhill.

▲ DANGER!

Never use reverse to reduce speed going downhill: this could cause you to lose control of the vehicle, especially on slippery ground.

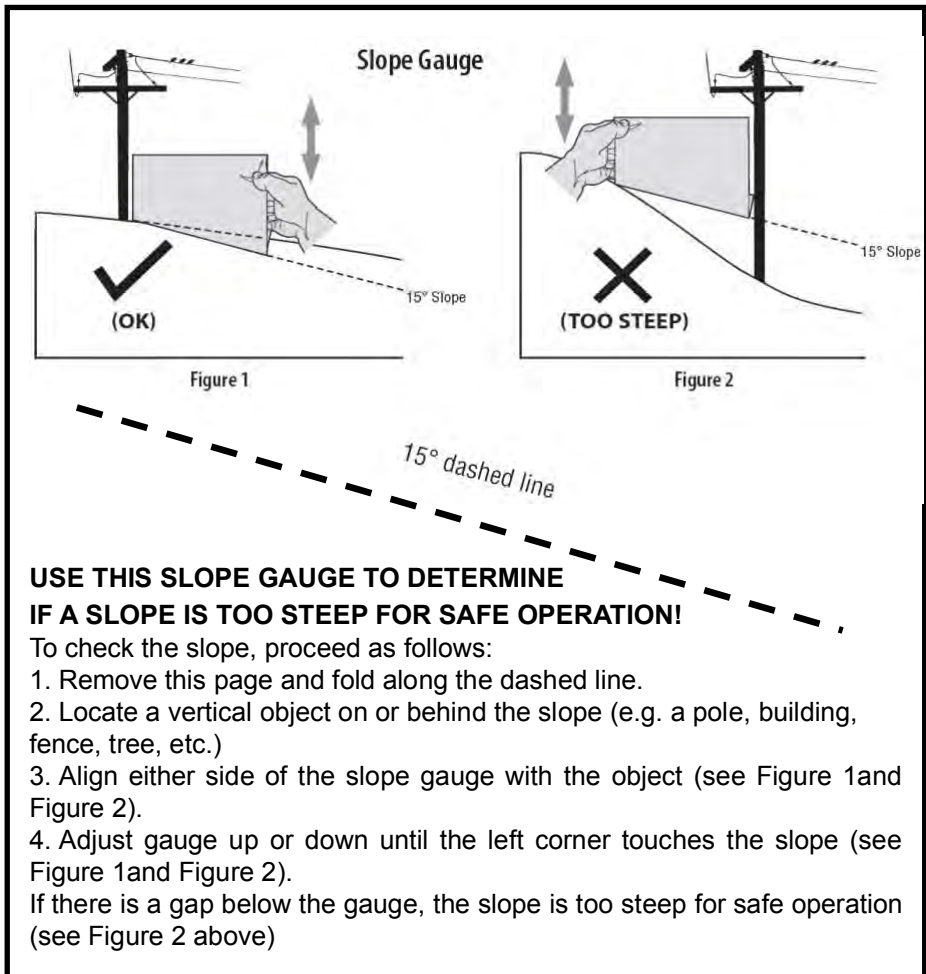

WARNING! Slopes are a major factor related to tip-over and accidents which can result injury or death. Do not operate machine on slope in excess of 15 degrees, all slopes require extra caution.

5.6 TRANSPORTING

▲ WARNING! *If the machine is transported on a truck or trailer, use suitable equipment for lifting and enough people for the weight involved and the type of lifting system used. The machine must never be lifted by rope and tackle. During transport, close the fuel stopcock, lower the cutting deck, apply the parking brake and fasten the machine securely with ropes or chains to the hauling device.*

5.7 LAWN MAINTENANCE

1. To keep a lawn green, soft and attractive, it should be cut regularly without damaging the grass. A lawn can be composed of different types of grass. If the lawn is cut frequently, grass and roots grow more vigorously, forming a solid grassy bed. If the lawn is cut less frequently, higher grass and weeds start growing (plus daisies and clovers, etc.).

2. It is always better to cut the grass when dry.

3. The blades must be in good condition and well sharpened so that the grass is cut straight without a ragged edge that leads to yellowing at the ends.

4. The engine must run at full speed, both to ensure a sharp cut of the grass and to get the necessary thrust to push the cuttings through the collector channel.

5. The frequency of mowing should be in relation to the rate of growth of the grass. The grass should not be left to grow too much between one cut and the next.

6. During hot and dry periods, the grass should be cut a little higher to prevent the ground from drying out.

7. The best height of the grass on a well-kept lawn is approx. 4-5 cm. With one cut, you do not need to remove more than a third of the total height. If the grass is very tall, it should be cut twice in a twenty-four hours period – the first time with the blades at maximum height, possibly reducing the cutting

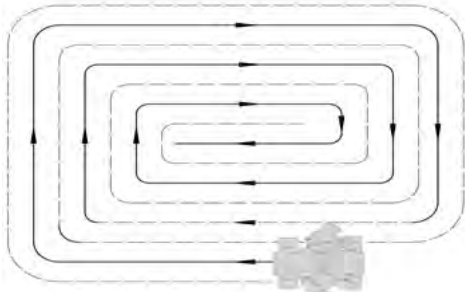

HOW TO USE THE MACHINE

width, and the second cut at the desired height.

8. When you mow large areas, start by turning to the right so that the cut grass will discharge away from shrubs, fences, drive-ways, etc. After one or two rounds, mow in the opposite direction making left turns until finished

9. The appearance of the lawn will improve if you alternate cutting in both directions.

10. If the collector system tends to get blocked with grass, you should reduce the forward speed as it may be too high for the condition of the grass. If the problem persists, the probable causes are either badly sharpened blades or deformed wings.

11. Be very careful when mowing near bushes or kerbs as these could distort the horizontal position of the cutting deck and damage its edge as well as the blades

6. MAINTENANCE

6.1 SAFETY RECOMMENDATIONS

▲ WARNING! *Before cleaning or doing maintenance work, take out the ignition key and read the relevant instructions. Wear adequate clothing and work gloves whenever your hands are at risk.*

▲ WARNING! *Never use the machine with worn or damaged parts. Faulty or worn-out parts must always be replaced and not repaired. Only use original spare parts: Parts that are not of the same quality can damage the equipment and affect your safety and that of others*

IMPORTANT *Never dispose of used oil, fuel, batteries or other pollutants in unauthorised places!*

6.2 SCHEDULED MAINTENANCE

6.2.1 Programmed maintenance

Operation	Hours	Completed (Date or Time)							
1. MACHINE									
1.1 Check engine oil	Before each use								
1.2 Tyres pressure check	Before each use								
1.3 Safety checks & Controls	Before each use								
1.4 Checking damage on products ⁽²⁾	Before each use								
1.5 Cleaning global product	After each use								
1.7 Check of fastening and sharpness blades ⁽²⁾	Each 25 hours								
1.8 Transmission belt check	Each 25 hours								
1.9 Blade blet check	Each 25 hours								
1.10 Bolt and screw check	Each 25 hours								
1.11 General Lubrication ⁽³⁾	Each 25 hours								
1.12 Blade replacement	Each 100 hours								
1.13 Global maintenance review made by Authorized Dealer or Service Center)	Every year								

MAINTENANCE

2. ENGINE

2.1: First Oil change⁽¹⁾	Each 20 hours								
2.2 Engine oil change ⁽¹⁾	Each 50 hours								
2.3 Air filter cleaning ⁽¹⁾	Each 50 hours								
2.4 Check and adjust Spark Plug ⁽¹⁾	Each 100 hours								
2.5 Fuel tank and fuel filters cleaning⁽¹⁾	Each 100 hours								
2.6 Air filter replacement ⁽¹⁾	Every year								
2.7 Spark plug replacement⁽¹⁾	Every year								

1) See the engine manual for the full list and frequency.

2) At the first signs of wear, contact your dealer to replace the part.

3) General lubrication of all joints should also be carried out whenever the machine is to be left unused for a long period.

The above table is there to help you maintain your machine's safety and performance. It shows the main maintenance and lubrication operations and their frequency. To the right of each item, there is a box where you can write the date or after how many operating hours the work was carried out.

▲ WARNING!

All checks, adjustments and replacements not described in chapters 6.3 and 6.4 of this manual must be carried out by your Dealer or a specialized Service Center. Both have the necessary knowledge and tools to ensure that the work is carried out correctly without affecting the safety of the machine.

6.2.2 Engine

IMPORTANT

Follow all the instructions in the engine manual.

To empty the engine oil, unscrew the oil plug. When refitting the plug, make sure the seal is positioned correctly.

6.2.3 Battery

The battery must be carefully maintained to ensure long life. The machine battery must always be charged:

- before using the machine for the first time after purchase;
- before leaving the machine disused for a long period;
- before starting up the machine after a long period of disuse.

Carefully read and observe the battery recharging instructions in the booklet provided with the battery. Failure in following the instructions or in charging the battery could permanently damage the battery cells.

A flat battery must be recharged as soon as possible.

IMPORTANT Recharging must be done using a battery charger at **constant voltage**. Other recharging systems can irreversibly damage the battery.

6.3 CHECKS AND ADJUSTMENTS

The cutting deck should be properly set to obtain a good cut.

NOTE

For achieving good results from cutting, the front part should always be 5-6mm lower than the rear.

–Put the machine onto a flat surface and check the tyre pressures;

– Put 30 mm blocks under the front edge of the deck and 35 mm blocks under the rear edge, and then put the deck lift handle into position «2»;

– Adjust the left front adjuster rod, right front adjuster rod and right rear adjuster rod keep the deck in touch with the blocks;

–Adjust the lift rod keep the deck in touch with the blocks.

For a flat lawn, if need, you can change the position of deck wheel to obtain a lower cut.

IMPORTANT For a heave lawn, you must set the deck wheel in the hole «A».

In case of any doubts, do not hesitate to contact your retailer.

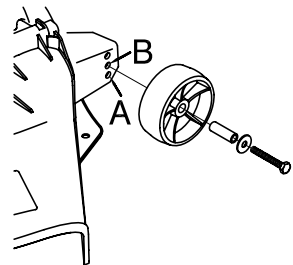
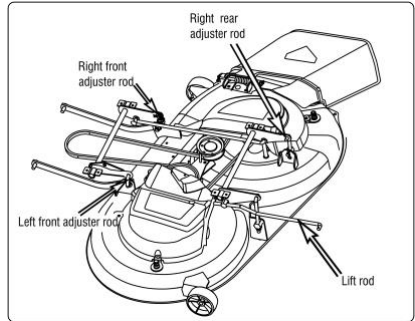

6.4 DISMANTLING AND REPLACEMENT

6.4.1 Replacing wheels

Stop the machine on flat ground and put a block under a load-bearing part of the frame on the side that the wheel is to be changed.

The wheels are held by a snap ring which can be eased off with a screwdriver.

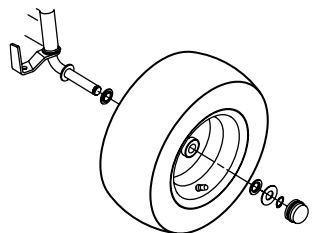

NOTE

If you must replace one or both rear wheels, they have the same diameter, and check that the cutting deck is horizontal to prevent an uneven cut. You must make sure the key and washer are securely lodged in place.

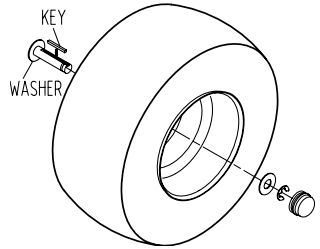

IMPORTANT

Before remounting the wheel, apply grease to the axle. Put the snap ring and supporting washer back in place.

6.4.2 Replacing and repairing the tyres

The tyres are “tubeless” and so all punctures must be repaired by a tyre repairer following the procedures required for this kind of tyre.

6.4.3 Replacing a fuse

The machine is fitted with 10A fuses. When it blows, the machine stops, the dashboard light switches off, and the battery gradually runs out, the machine will have problems starting.

Remove the fuse and replace with a same type fuse.

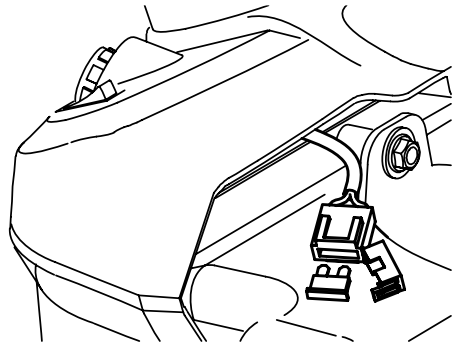

IMPORTANT

A blown fuse must always be replaced by one of the same type and ampere rating, and never with one of another rating.

6.4.4 Dismantling, replacing and remounting the blades

▲ WARNING!

Always wear work gloves when handling the blades. Before you inspect or remove the blade, stop the engine and disconnect the wire to the spark plug.

▲ WARNING!

Damaged or bent blades must always be replaced; never try to repair them! ALWAYS USE OEM REPLACEMENT BLADES! Make sure the blades are correctly balanced. Make sure you put them back in the right place by referring to the code and rotate direction stamped on the outside of each blade.

For blade models, please refer to the chapter “SPECIFICATIONS”.

1. Dismantling

Loosen anticlockwise the screw.

2. Remounting

MAINTENANCE

Make sure the printed code on the blade faces the operator who remounted the blade.

Check that the concave part of the disc washer presses against the blade.

Remount the shaft hubs, making sure the key is securely lodged in place.

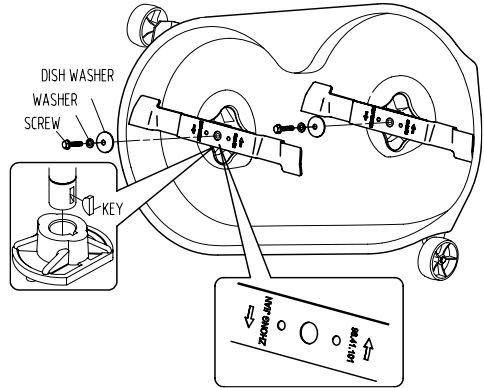

3. Tightening the screws

Tightening clockwise with a torque wrench calibrated to 40~45N.m.

6.4.5 Replacing the belt

The belt replacement must be carried out at a Licensed Service Centre. Replace the belts as soon as they show obvious sign of wear!

▲ WARNING! ALWAYS USE GENUINE REPLACEMENT BELTS!

6.5 LUBRICATION

Apply grease with an injector to the areas shown. Apply two or three shots of grease and wipe off any excess.

Lubricate the areas shown with engine oil. wipe the area clean, apply a few drops of oil, then wipe up drips or spills.

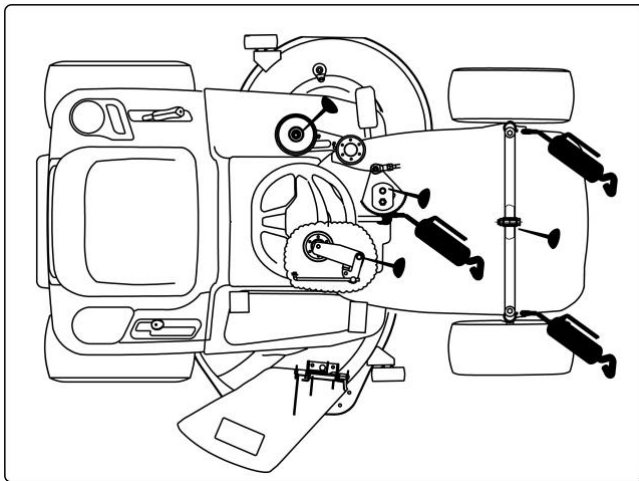

IMPORTANT

Do not dirty the belt, brake shoe or tire with grease or oil. Oil or grease will damage them.

7. TROUBLESHOOTING



WARNING!

Danger

Injury hazard if engine is started inadvertently

Protect yourself against injury. Before carrying out any work on this mower:

- Switch off the engine.
- Remove the ignition key.
- Actuate the parking brake.
- Wait until all moving parts have come to a standstill and the engine has fully cooled.
- Pull the spark plug connector off the engine so that the engine cannot inadvertently start.

Faults which occur while you are using your mower often have simple causes which you should know and may be able to rectify yourself. If you are in any doubt, however, your dealer or service center will be happy to provide assistance.

Problem	Possible cause(s)	Remedy
Lighting does not function	1. Headlight wire not connected.	Stop the key to «STOP» position and connect the headlight wire.
	2. Bulbs defective.	Stop the key to «STOP» position and replace the bulbs.
	3. Battery not connected correctly.	Connect red cable to the (+) battery terminal and black cable to (-) battery terminal. (par. 3.4)
	4. Ignition switch defective	Replace ignition switch
	5. Battery defective	Test and recharge or replace the battery
	6. Short-Circuit in wire harness	Contact your Dealer or Service center

TROUBLESHOOTING

Problem	Possible cause(s)	Remedy
Start motor will not turn engine	1. Starting conditions have not been met	Check that all starting conditions are met (par. 5.4.1)
	2. No fuel in fuel tank.	Stop the key to «STOP» position and refuel the fuel tank. (par. 5.3.3)
	3. Poor contact between cable and battery pole.	Check the connections.(par. 3.4)
	4. Battery flat or defective	Test and recharge or replace the battery.
	5. Fuse defective.	Replace fuse. If the fuse blows repeatedly, determine the cause (usually a short-circuit). (par. 6.4.3)
	6. Clogged air filter	Clean air filter.
	7. Spark Plug defective.	Check the connection of spark plug socket, Clean or replace the spark plug.
	8. Brake pedal defective.	Contact your Dealer or Service center.
	9.Clutch/brake switch not pushed down.	Press the PTO Button to the OFF position. (par. 4.3)
	10. Start relay defective	Replace the start relay.
	11.Ignition switch start defective	Replace ignition switch start.

TROUBLESHOOTING

Problem	Possible cause(s)	Remedy
Engine runs unevenly	1. Carburetor problem	Contact your Dealer or Service center.
	2. Air filter blocked.	Clean or replace the air filter.(See engine manual)
	3. Fuel tank ventilation blocked.	1.Check and replace the fuel filter if necessary;(see engine manual or or contact your Dealer or Service center.) 2. Empty the fuel tank and refuel with fresh fuel;
	4. Grass is too high	Reduce the travelling speed according to the height of the grass and/or raise the cutting height.
Engine feels weak	1. Air filter blocked.	Clean or replace the air filter.(See engine manual)
	2. Engine speed too low	Increase throttle.
	3. Travelling speed too high.	Set to a lower travelling speed.
	4. Spark Plug defective.	Replace the spark plug; see engine manual.
	5. Fuel tank ventilation blocked	1.Check and replace the fuel filter if necessary;(see engine manual or or contact your Dealer or Service center.) 2. Empty the fuel tank and refuel with fresh fuel;

TROUBLESHOOTING

Problem	Possible cause(s)	Remedy
Battery does not charge	1. Fuse defective.	Replace fuse. If the fuse blows repeatedly, determine the cause (usually a short-circuit). (par. 6.4.3)
	2. Poor contact between battery poles and cables.	Check the connections.(par. 3.4)
Machine doesn't move	1.Brake is engaged	Keep the brake pedal pressed down and release the parking brake, release the brake pedal slowly to start forward movement of the machine. (par. 5.4.2)
	2. Gearbox disengaged (Hydrostatic Gear)	Engage the gearbox. (par. 5.3.5)
	3.Drive belt detached	Fit belt in place.
	4.Drive belt defective or worn	Replace drive belt.
Strong vibrations	1. Blades loose.	Check and tighten all the blades (see Torque tightening par. 6.4.4) or contact your Dealer or Service center.
	2. Engine loose.	Check and tighten all the engine and frame bolts
	3. Unbalance in one or both blades resulting from damage.	Contact your Dealer or Service center.
	4. Cutting-means assembly is full of grass	Clean the cutting-means assembly
	5.Engine mounting not securely tightened	Tighten engine mounting or contact your Dealer or Service center.
	6. Belt damaged	Replace Belt

TROUBLESHOOTING

Problem	Possible cause(s)	Remedy
Uneven or poor cutting results	1. Blades blunt or worn	Sharpen or replace mowing blades
	2. Different air pressures in tires on left and right side.	Check the tyre pressure.(par. 5.3.2)
	3.Cutting deck adjustment.	Check deck adjustment (6.3 or Contact your Dealer or Service center)
	4.Long and/or wet grass	Adapt cutting level and driving speed to the mowing conditions.
	5.Travelling speed too high.	Set to a lower travelling speed.
	6. Grass stuck under cutting deck	Cleaning inside the deck properly (Use a suitable accessory to access the cleaning of the cutting deck)
	7.Cutting drive belt Slipping	Replace the cutting drive belt

If problems persist after having performed the above operations, contact your Dealer or Service center.

8. SPECIFICATIONS

8.1 TECHNICAL DATA TABLE

Model	TTM98SH-L452	
Engine model	LC1P92F-1	
Engine displacement	452 cm³	
Nominal power:	8.3 kW	
Max. engine speed:	2800min⁻¹	
Blade model:	98.41.101	
Cutting width	98 cm	
Sound pressure level at the operator position	L_{pA}: 83.6 dB(A), K_{pA}: 3 dB(A)	
Guaranteed sound power level (2000/14/EC)	L_{WA}: 100 dB(A)	
Vibration	Hand-arm	a_h: 2.99 m/s², K_h: 0.07 m/s²
	Whole body	a_h: 2.66 m/s², K_h: 0.11 m/s²
Mass	168.5 kg	
Driving speed	Forward:0-8.8 km/h, Reverse 0-4.5 km/h	

Model	TTM108SH-L586	
Engine model	LC2P73F	
Engine displacement	586 cm³	
Nominal power:	11.4 kW	
Max. engine speed:	2800min⁻¹	
Blade model:	108.41.101	
Cutting width	108 cm	
Sound pressure level at the operator position	L_{pA}: 84.0 dB(A), K_{pA}: 3 dB(A)	
Guaranteed sound power level (2000/14/EC)	L_{WA}: 100 dB(A)	
Vibration	Hand-arm	a_h: 3.22 m/s², K_h: 0.07 m/s²
	Whole body	a_h: 2.31 m/s², K_h: 0.11 m/s²
Mass	174.5 kg	
Driving speed	Forward:0-8.8 km/h, Reverse 0-4.5 km/h	

	For all models
Blade screw tightening torque	40–45 Nm
Cutting height (on 7 levels)	30 – 90 mm
Front wheels	15 × 6.00-6
Rear wheels	18 × 8.50-8
Front wheel inflation pressure	1.0 bar
Rear wheel inflation pressure	1.2 bar
Electrical system	12 Vd.c.
Battery	18 Ah
Min. turning radius	45 cm
Capacity of fuel tank	7.5 L

8.2 Machine Dimensions

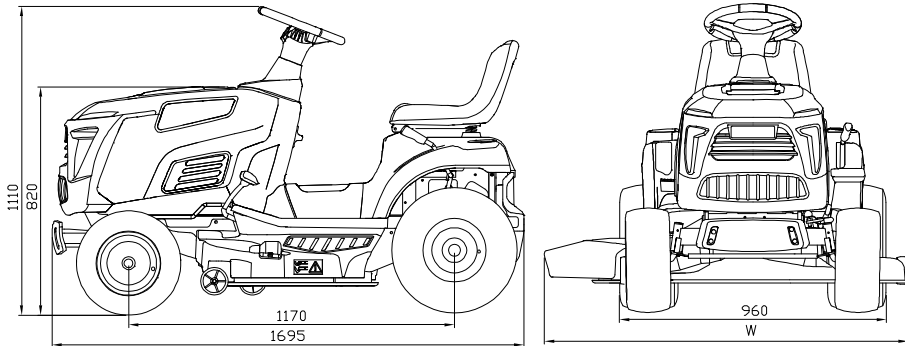

Model	TTM98SH	TTM108SH
W(mm)	1210	1315

For Garden Products

OWNER'S WARRANTY

IMPORTANT. Please read the Owner's Manual and Warranty before using this product. The Warranty does not cover damage due to misuse or failure to follow the instructions.



THE MASPORT EXPRESS WARRANTY RIDE-ON PRODUCTS

1. Warranty provider

1.1. The Express Warranty set out below is provided by Masport Limited, a New Zealand company located at 320 Ti Rakau Drive, East Tamaki, 2013, Auckland, New Zealand. For any questions regarding this Express Warranty or to make a warranty claim call 0800 627 767 (New Zealand) or 1300 366 225 (Australia), or contact your local Masport Specialist retailer.

2. General warranty coverage

2.1. The New Zealand Consumer Guarantees Act 1993 ("New Zealand Consumer Act") and the Australian Competition and Consumer Act 2010 (including the Australian Consumer Law 2011) ("Australian Consumer Law"), as well as other laws in each of those jurisdictions, guarantee or imply certain conditions, warranties and undertakings, and give you other legal rights, in relation to the quality and fitness for purpose of our products sold in New Zealand and Australia respectively.

2.2. For products sold in New Zealand, these conditions, warranties and undertakings cannot be modified or excluded by any contract, except in those circumstances contemplated by section 43(2) of the New Zealand Consumer Act.

2.3. For products sold in Australia, our goods come with guarantees that cannot be excluded under the Australian Consumer Law. You are entitled to a replacement or refund for a major failure and for compensation for any other reasonably foreseeable loss or damage. You are also entitled to have the goods repaired or replaced if the goods fail to be of acceptable quality and the failure does not amount to a major failure. What constitutes a major failure is set out in the Australian Consumer Law.

3. Express Warranty

3.1. Where the Product is for Personal Use, Masport will repair or replace (at Masport's sole option) each Product Component in the table below, that suffers from a material defect in workmanship or materials from the date the Product is originally purchased until the end of the warranty period set out in the table below for each Covered Product Component .

Covered Product Components	Domestic
Battery	90 Days
Engine & Transmission	See Manufacturers Warranty for these Parts
Masport TTM Series Rideon	2 years, plus 1 year upon registration (3 years total)

3.2. Despite the warranty period listed above, where the Product is used for business, commercial, industrial, institutional, rental or other income-producing purposes, the warranty period for each Product is 3 months from the date the Product is originally purchased.

3.3. For both the Express Warranty for Personal Use and Commercial Use:

- (a) the Express Warranty is subject to Masport firstly verifying the existence of the material defect and determining that the warranty claim is valid. Any repaired or replaced product will be covered by the Express Warranty for the remainder of the original warranty or usage period only; and
- (b) The repair or replacement by Masport may be performed by a Masport agent or Specialist Retailer. You will not be charged for any labour costs involved in the replacement or repair, but you must bear the cost of transporting or delivering the Product to and from the location of the Masport agent or Specialist Retailer where the warranty claim is made.

3.4. Masport warrants that repair facilities and spare parts will be made available for each Product only from the date the Product is originally purchased until the end of the applicable warranty period as set out in clauses 3.1 and 3.2, but for no longer period.

4. Exclusions from Express Warranty

- 4.1 The Express Warranty does not apply where any defect, malfunction or failure is caused or contributed to by any of the following:
- (a) engines or transmissions as these are protected by their manufacturers' warranties - refer to the Engine Manufacturer's Warranty in the Engine/Owner's Manual supplied with your Ride-on lawnmower;
 - (b) failure to follow the fuel selection instructions, engine and product operating and maintenance instructions;
 - (c) modification, repairs or alteration of the Product carried out by persons other than authorised Masport service agents;
 - (d) acts or omissions by anyone other than Masport after the Product has left Masport's control;
 - (e) normal wear and tear;
 - (f) accidental damage, neglect, misuse;
 - (g) any event outside of Masport's reasonable control, including without limitation, adverse weather conditions;
 - (h) sharpening or setting of blades; or
 - (i) pre-delivery assembly of the Product by anyone except for Masport, Masport authorised service agents or any other person authorised by Masport.

5. Express Warranty in addition to consumer protection laws

- 5.1. Despite anything else in this warranty card, nothing in this warranty card will exclude, limit or modify any Consumer Protection Warranty or any liability of Masport imposed by applicable law if to do so would be unlawful or make any part of this warranty card void or voidable.
- 5.2. The Express Warranty is in addition to any Consumer Protection Warranty that may apply, for example, under the New Zealand Consumer Act or the Australian Consumer Law, or under the laws of the place where the Product was purchased. To the extent permitted by applicable law, Masport's liability for breach of any warranty, term, condition, guarantee or similar that cannot be excluded under the New Zealand Consumer Act or Australian Consumer Law (other than those under sections 51 – 53 of the Australian Consumer Law, to the extent applicable) is limited (at Masport's sole option) to Masport repairing or replacing the relevant Product or Product Component or paying for such repair or replacement.

6. No other warranties or liability

- 6.1. Except as otherwise provided in the Express Warranty, all express or implied warranties, guarantees, conditions or terms in relation to the Product and Product Components (other than those which cannot be excluded or limited under the New Zealand Consumer Act, the Australian Consumer Law or the laws of the place where the Product is purchased) are expressly excluded to the extent legally permitted.
- 6.2. All statements, technical information and recommendations about the Product and Product Components are believed to be reliable, but do not constitute a guarantee or warranty. No statements, representations or recommendations other than those contained in the official technical information published by Masport, will bind Masport, unless made in writing signed by an authorised representative of Masport.
- 6.3. Subject to Clause 5, in no event will Masport be liable (whether in contract, tort, negligence or in any other way) for:
- (a) loss of profits or savings, loss of goodwill or opportunity, loss of production or wasted time; or
 - (b) loss, damage, cost or expense of any kind whatsoever which is indirect, consequential, or of a special nature, arising directly or indirectly from the Product, even if Masport had been advised of the possibility of such damages.
- 6.4. Subject to Clause 5, in no event will Masport's total liability under any claim of whatever nature arising directly or indirectly from the Product exceed the price you paid for the Product.
- 6.5. This warranty card embodies the entire agreement between you and Masport in relation to the subject matter of this warranty card and supersedes all prior understandings, communications and representations between you and Masport, whether oral or written. No amendment to this warranty card will be effective unless in writing and signed by an authorised representative of Masport. You may not assign or transfer the Express Warranty without the prior written consent of Masport. This warranty card will be governed by the law of New Zealand for Products purchased in New Zealand and the laws of Australia for Products purchased in Australia. You and Masport will be subject to the non-exclusive jurisdiction of the New Zealand and Australian courts.

7. How to obtain service for a faulty Product

- 7.1. You must return the Product to the place of purchase or any Masport specialist retailer, along with reasonable evidence of the date the Product was purchased, for example, an original receipt.
- 7.2. Masport or its agent will assess the claim and if accepted, will repair or replace the Product or Product Component in accordance with the normal practices of the relevant Masport service agent.
- 7.3. All claims under any Express Warranty must be made within the relevant warranty period or usage period.

8. Definitions

In this warranty card:

- 8.1. **"Commercial Use"** means any use of the Product for business, commercial, industrial, institutional, rental or other income-producing purposes;
- 8.2. **"Consumer Protection Warranty"** means any warranty, guarantee, term, condition, right or remedy implied or imposed by applicable law;
- 8.3. **"Express Warranty"** means the Express Warranty for Personal Use set out in Clause 3.1 and the Express Warranty for Commercial Use set out in Clause 3.2;
- 8.4. **"Masport"** means Masport Limited, a New Zealand company located at 320 Ti Rakau Drive, East Tamaki, 2013, Auckland, New Zealand with an Australian office located at 27 Commercial Drive, Dandenong South, Victoria 3175, Australia;
- 8.5. **"Personal Use"** means any use that is not Commercial Use;
- 8.6. **"Product"** means the Masport product accompanying this warranty card;
- 8.7. **"Product Component"** means each component of the Product set out in the table under clause 3.1, excluding engines and transmissions; and
- 8.8. **"You"** means the original purchaser of the Product.

Thank you for purchasing your Masport product. We know that you'll enjoy it!
To register your product warranty, simply visit our website: www.masport.com.

Failure to register your product warranty will not affect your rights under any Consumer Protection Warranty, however registration may help Masport deal with any warranty claim more efficiently.

Masport[®]

320 Ti Rakau Drive, Burswood,
Auckland 2013
New Zealand