



Parts Manual

Mfg. No: 2691870-00
RIDE-ON, FER SD 15.5HP 38" H

Model Components	Page
Brake Group.....	4
Clutch - Cutting (38") Group.....	6
Deck and Blades (38") Group.....	8
Discharge and Belt Guards Group.....	12
Drive Belt (38") Group.....	14
Engine & Controls Group.....	16
Front Axle Group.....	18
Fuel Tank Group.....	20
H Electrical Group.....	22
H Frame FER Group.....	24
H Hood Cover Group.....	26
Lift (38") Group.....	28
Muffler Shield Group.....	30
Mulch Cover Group.....	32
Rear Axle Group.....	34
Seat Group.....	36
Shift Group.....	38
Steering Group.....	40
Wiring Schematic.....	42
Wiring Schematic - Starter.....	44
Torque Specification Chart.....	46

Not For
Reproduction

Brake Group

Note: Unless noted otherwise, use the standard torque specifications

Mfg. No: 2691870-00

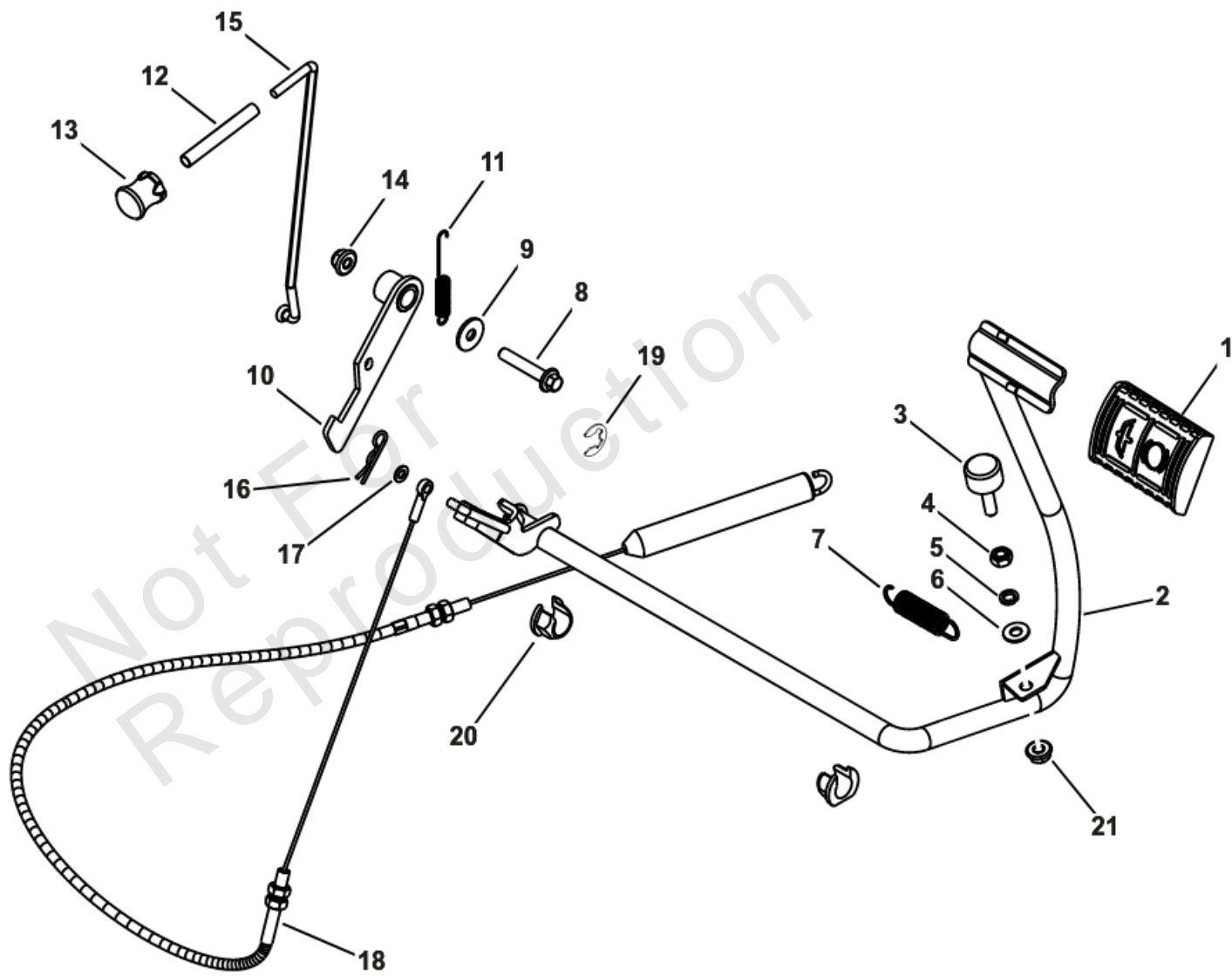

Brake Group

REF NO	PART NO	QTY	DESCRIPTION
1	80100957	1	PEDAL BRAKE
2	80101277	1	LEVER ASSEMBLY, BRAKE
3	80100878	1	DAMPER PAD
4	-----	1	NUT HEX M8
5	-----	1	WASHER, SPRING M8
6	-----	1	WASHER, FLAT M8
7	80101276	1	SPRING, BRAKE LEVER
8	-----	1	BOLT, HEX FLANGE - M8x45
9	-----	1	WASHER, FLAT 8.4ID x 24OD x 2MM
10	80101204	1	HOOK, PARKING BRAKE
11	80101203	1	SPRING, RETURN - PARK BRAKE
12	-----	1	SLEEVE, PARKING ROD
13	80101205	1	KNOB, PARK BRAKE
14	-----	1	LOCKNUT, HEX FLANGE - M8
15	80101202	1	ROD, PARKING BRAKE
16	80100954	1	R CLIP 10 DIA SHAFT X 2mm DIA
17	-----	1	WASHER, FLAT M6 x 1.2mm
18	80101278	1	CABLE, BRAKE
19	-----	1	E-CLIP 12 DIA x 1.2mm
20	80100958	2	BUSH OPEN SNAP-ON
21	-----	1	NUT HEX M8

Clutch - Cutting (38") Group

Note: Unless noted otherwise, use the standard torque specifications

Mfg. No: 2691870-00

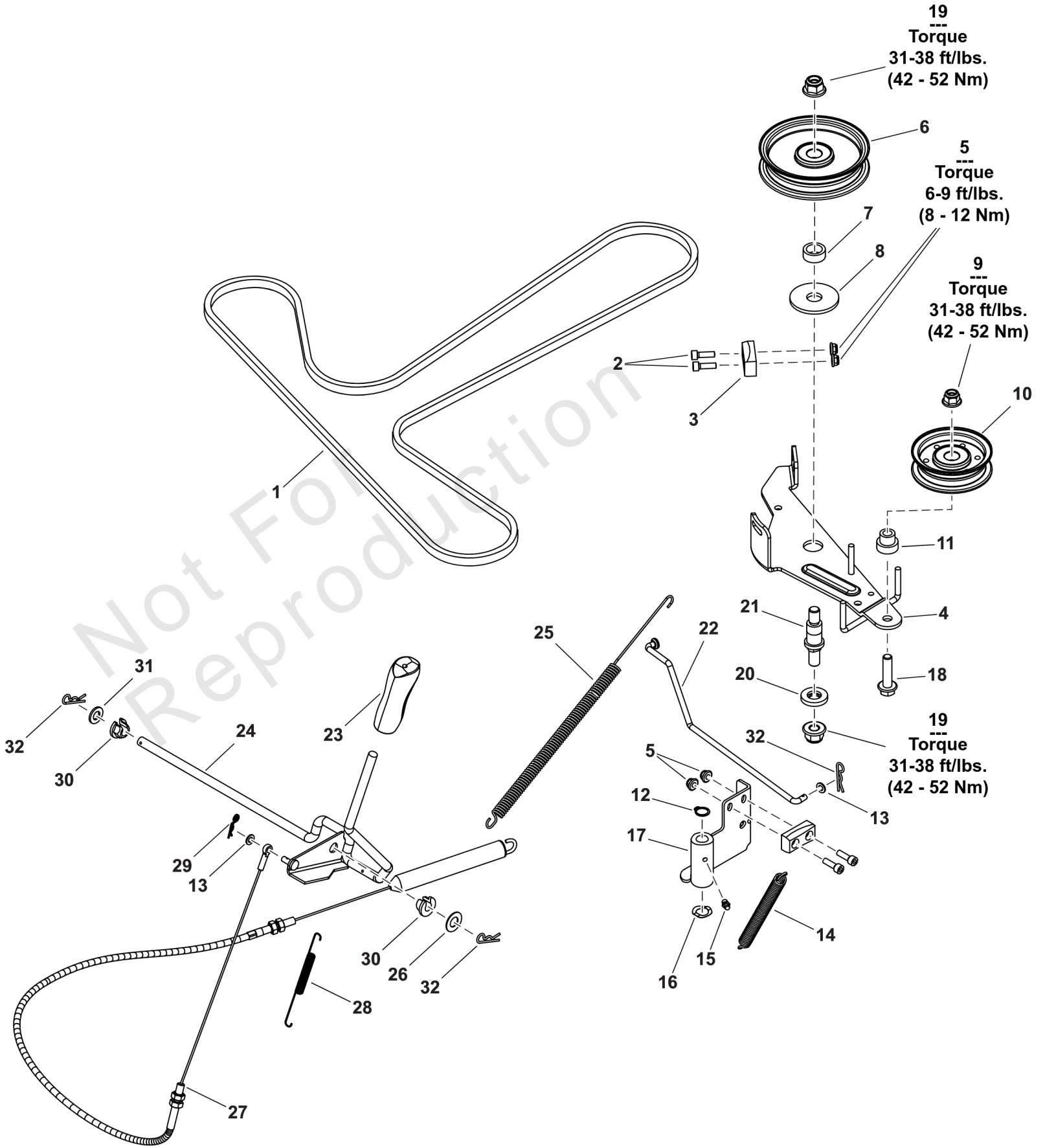

Clutch - Cutting (38") Group

REF NO	PART NO	QTY	DESCRIPTION
1	80101621	1	V-BELT, 48x900
2	-----	4	SCREW, SOCKET HEAD CAP M6X20
3	80100867	2	BRAKE SHOE
4	80101167	1	BRACKET, PIVOT ARM
5	-----	4	LOCKNUT HEX FLANGE M6
6	80101170	1	PULLEY, IDLER
7	80101160	1	BUSH, IDLER PULLEY
8	80101158	1	WASHER, FLAT
9	80100707	1	LOCKNUT HEX FLANGE M10x1.25
10	80101302	1	PULLEY, TENSION
11	80101295	1	BUSH, TENSION PULLEY
12	80100779	1	CIRCLIP EXTERNAL 13MM
13	-----	1	WASHER, FLAT M6 x 1.2mm
14	80101164	2	SPRING EXT DRIVE
15	80100813	1	GREASE NIPPLE, M6
16	-----	1	WASHER, WAVE M14x0.4MM
17	80101166	1	BRACKET, BRAKE ARM
18	80100665	1	BOLT, HEX FLANGE
19	-----	2	LOCKNUT HEX FLANGE M12X1.25
20	80101159	1	BUSH, IDLER ARM
21	80101161	1	SHAFT, IDLER PULLEY
22	80101153	1	ROD, CUTTING - R (38")
23	80101162	1	HANDLE
24	80101169	1	LEVER ASSEMBLY, CLUTCH
25	80101154	1	SPRING, EXTENSION - LEFT BRAKE
26	-----	1	WASHER, FLAT 12.4ID x 24OD x 1MM
27	80101168	1	CABLE, CUTTING CLUTCH
28	80101157	1	SPRING, CLUTCH LEVER
29	80100956	1	R CLIP 6 DIA SHAFT X 1.4mm DIA
30	-----	2	BUSH, OPEN - SNAP ON
31	-----	1	WASHER, FLAT M10 X 2
32	80100954	3	R CLIP 10 DIA SHAFT X 2mm DIA

Deck and Blades (38") Group

Note: Unless noted otherwise, use the standard torque specifications

Mfg. No: 2691870-00

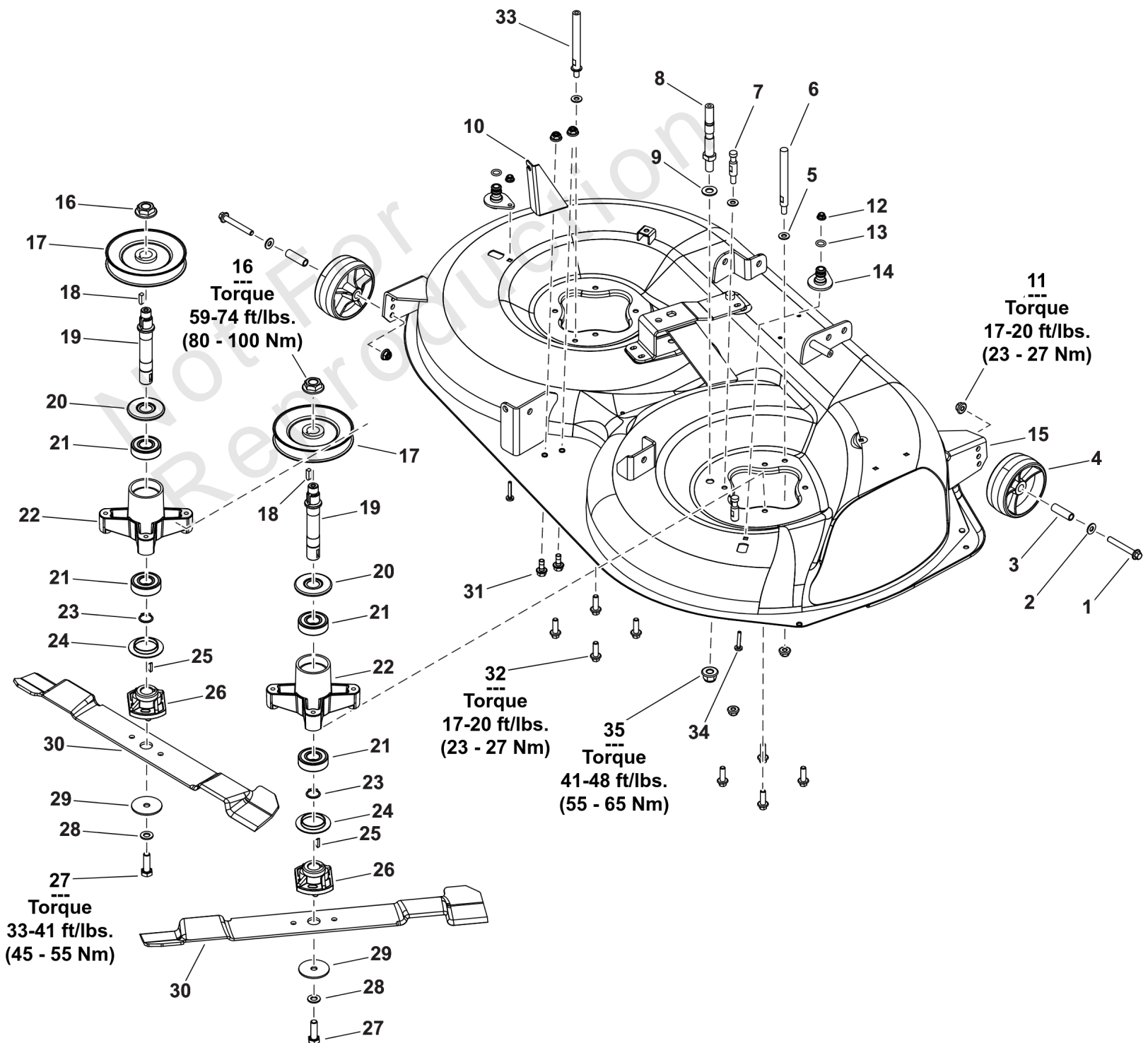
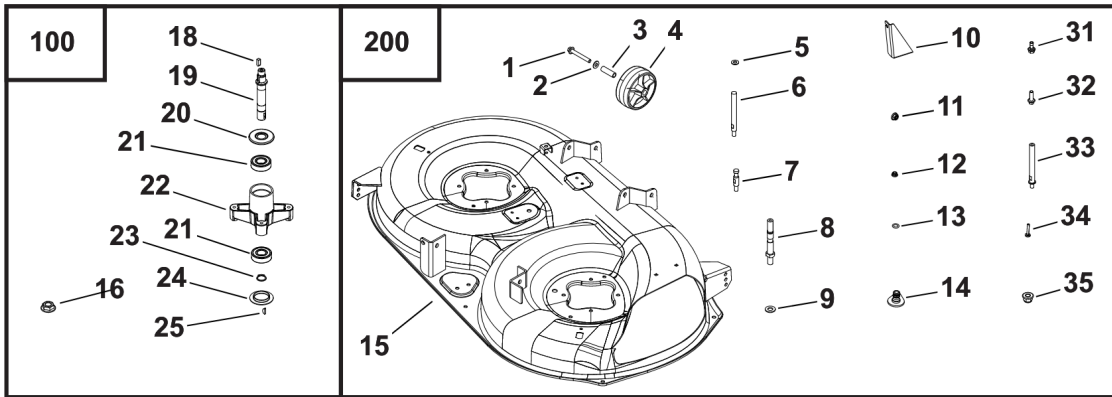

Deck and Blades (38") Group

REF NO	PART NO	QTY	DESCRIPTION
1	80100673	2	BOLT, HEX FLANGE - M8x60 -(Included with Ref. No. 200)
2	-----	2	WASHER, FLAT M8 -(Included with Ref. No. 200)
3	80101317	2	BUSH, AXLE -(Included with Ref. No. 200)
4	80101316	2	WHEEL, LEVELING -(Included with Ref. No. 200)
5	-----	3	WASHER, FLAT 8.1ID x 17OD x 1.6 -(Included with Ref. No. 200)
6	80101165	1	STUD -(Included with Ref. No. 200)
7	80101163	1	POST, TENSION SPRING -(Included with Ref. No. 200)
8	80101152	1	POST, RIGHT BRAKE -(Included with Ref. No. 200)
9	-----	1	WASHER, FLAT - M12x2mm -(Included with Ref. No. 200)
10	80101156	1	BRACKET, CABLE SUPPORT -(Included with Ref. No. 200)
11	-----	7	LOCKNUT HEX FLANGE M8 -(Included with Ref. No. 200)
12	-----	2	LOCKNUT HEX FLANGE M6 -(Included with Ref. No. 200)
13	-----	2	O-RING 11.2 DIA x 1.8 DIA -(Included with Ref. No. 200)
14	80100988	2	CONNECTION, WATER HOSE -(Included with Ref. No. 200)
15	80101225	1	DECK - 38" -(Included with Ref. No. 200)
16	80100990	2	NUT HEX FLANGE M16 x 2mm
17	80100997	2	PULLEY CUTTING
18	80100814	2	KEY FLAT 6 x 6 x 18mm -(Included with Ref. No. 100)
19	80100985	2	SPINDLE BLADE -(Included with Ref. No. 100)
20	80101319	2	COVER DUST TOP BEARING -(Included with Ref. No. 100)
21	80100805	4	BEARING 6204-2RZ -(Included with Ref. No. 100)
22	-----	2	HOUSING BEARING -(Included with Ref. No. 100)
23	80100778	2	CIRCLIP EXTERNAL 19 DIA -(Included with Ref. No. 100)
24	80100995	2	COVER DUST BOTTOM BEARING -(Included with Ref. No. 100)
25	80100815	2	KEY WOODRUFF 4x16mm -(Included with Ref. No. 100)
26	80100984	2	SLEEVE LOCKING
27	80100670	2	BOLT, HEX HEAD 3/8"-24 x 1-1/4 (10.9 GRADE)
28	-----	2	WASHER, FLAT M10 X 2
29	80100986	2	WASHER, FLAT 10 ID x 48 OD x 2.5mm
30	80101670	2	BLADE BAR, 38"
31	-----	2	BOLT, HEX FLANGE - M8x16 -(Included with Ref. No. 200)
32	-----	8	BOLT, HEX FLANGE HEAD M8 x 25 -(Included with Ref. No. 200)
33	80101155	1	STUD -(Included with Ref. No. 200)

Deck and Blades (38") Group

Note: Unless noted otherwise, use the standard torque specifications

Mfg. No: 2691870-00

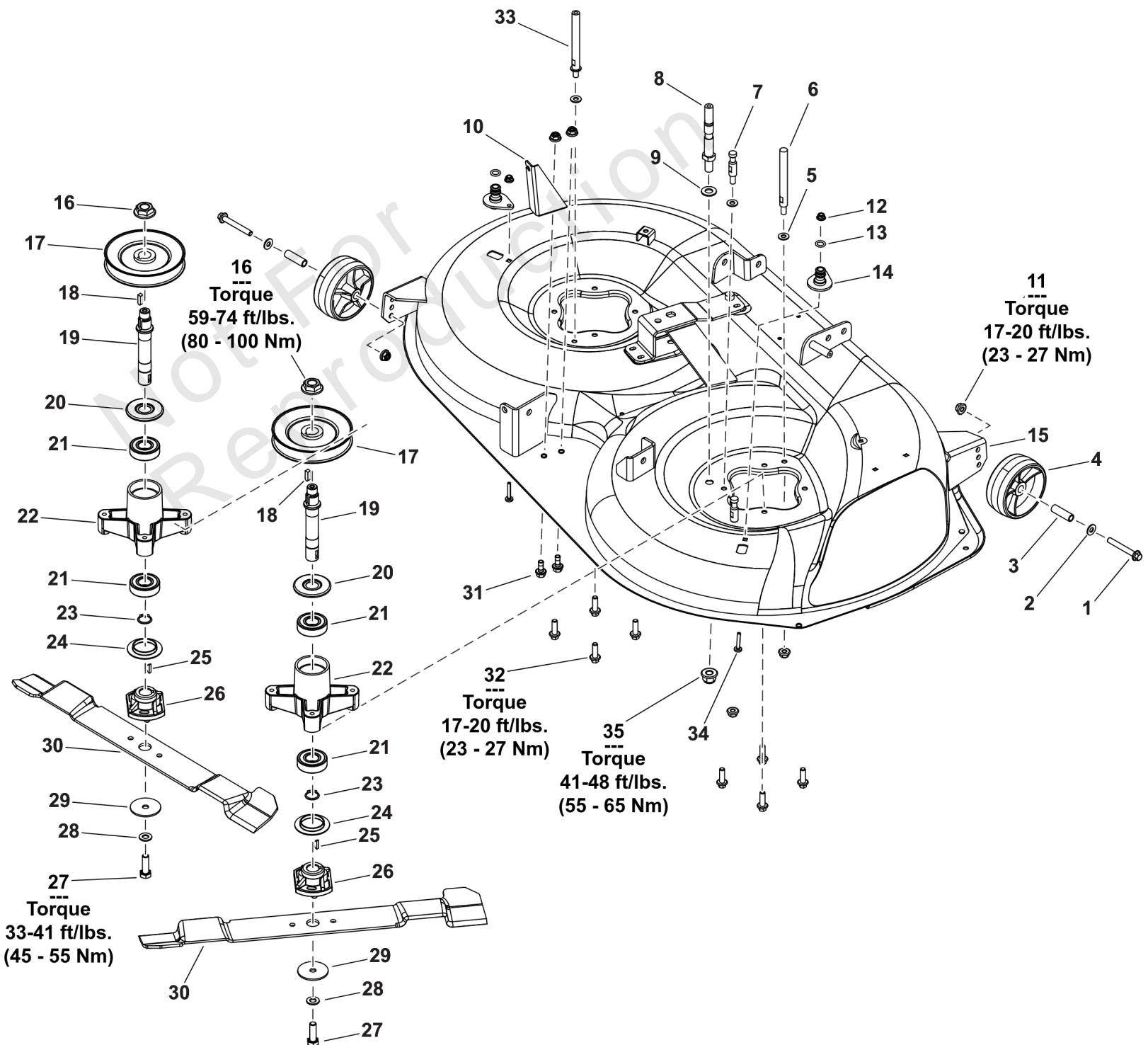
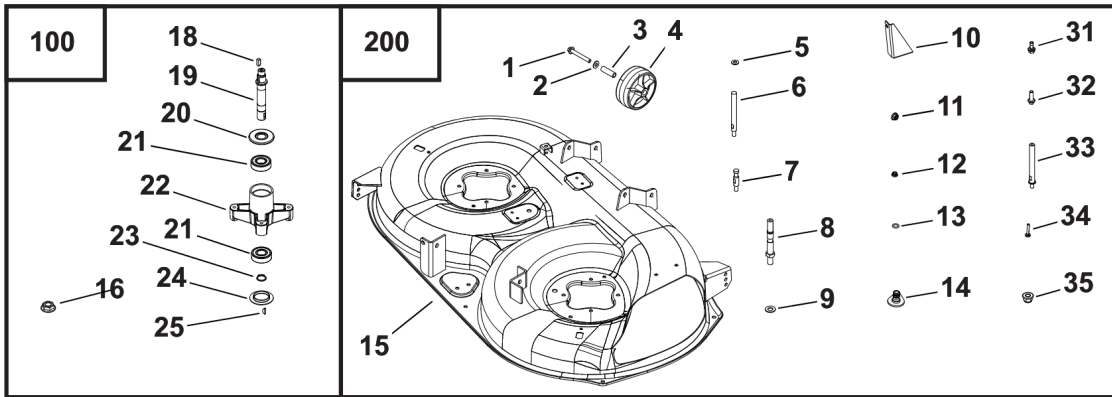

Deck and Blades (38") Group

REF NO	PART NO	QTY	DESCRIPTION
34	-----	2	SCREW, PAN HEAD PHILLIPS - M6x30 -(Included with Ref. No. 200)
35	-----	1	LOCKNUT HEX FLANGE M12X1.25 -(Included with Ref. No. 200)
100	80104195		KIT, SPINDLE ASSY -(Incl. Ref. Nos. 18-25)
200	80102238		KIT, DECK ASSY 38" -(Incl. Ref. Nos. 1-15 & 31-35)

Not For Reproduction

Discharge and Belt Guards Group

Note: Unless noted otherwise, use the standard torque specifications

Mfg. No: 2691870-00

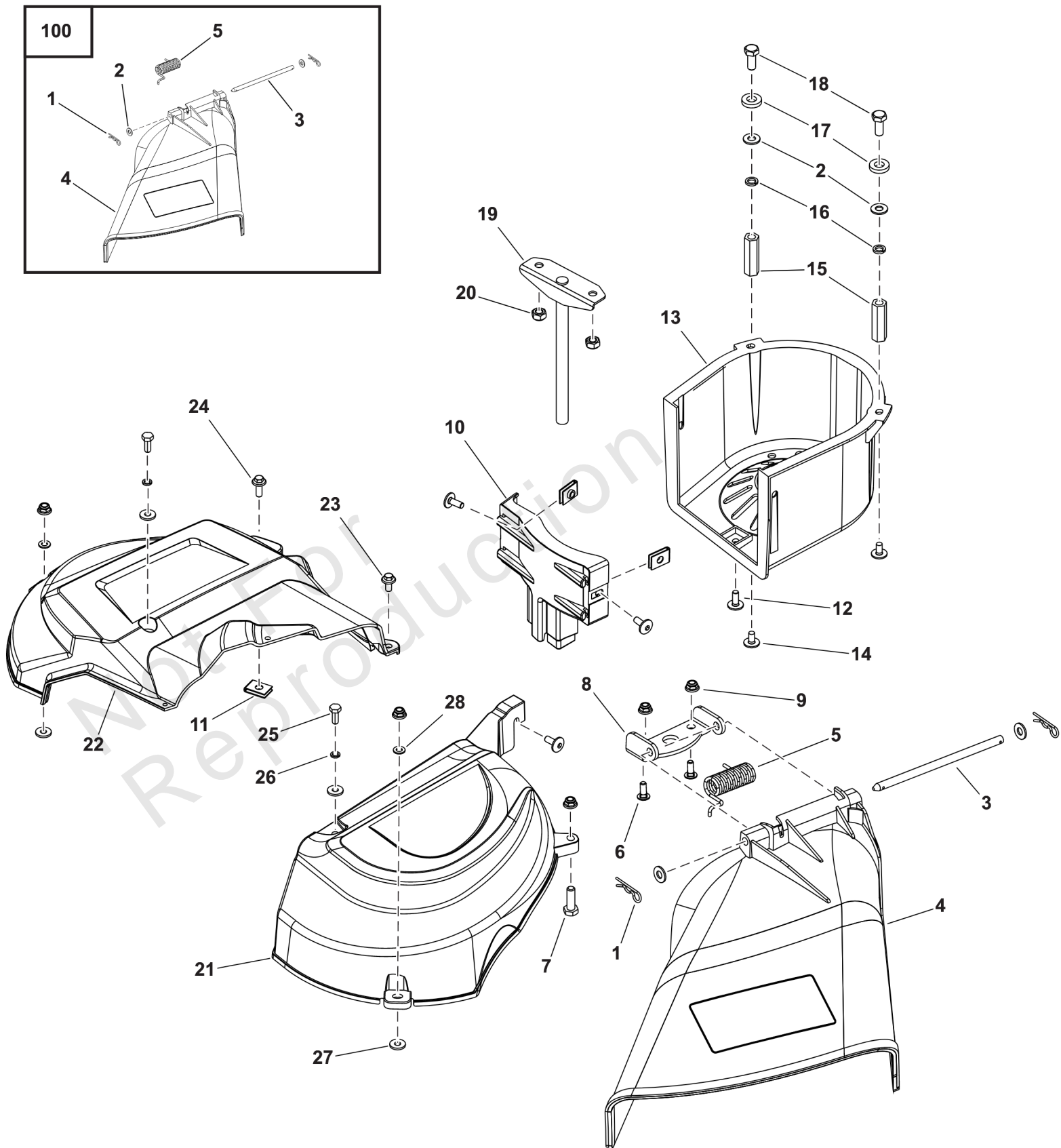

Discharge and Belt Guards Group

REF NO	PART NO	QTY	DESCRIPTION
1	80100954	2	R CLIP 10 DIA SHAFT X 2mm DIA -(Included with Ref. No. 100)
2	-----	4	WASHER, FLAT 8.1ID x 17OD x 1.6 -(Included with Ref. No. 100)
3	80101252	1	PIN SIDE DISCHARGE -(Included with Ref. No. 100)
4	-----	1	GUARD SIDE DISCHARGE -(Included with Ref. No. 100)
5	80101200	1	TORSION SPRING SIDE DISCHARGE -(Included with Ref. No. 100)
6	-----	2	BOLT, SQ NECK HALF ROUND HEAD M6X16
7	-----	1	BOLT, HEX HEAD - M8x25
8	80101201	1	HINGE, EJECTOR CHUTE
9	-----	5	LOCKNUT HEX FLANGE M6
10	-----	1	COVER, BELT - REAR
11	-----	3	U-NUT M6
12	-----	4	SCREW, FLAT HEAD SOCKET CAP M6x16
13	20101249	2	COVER, BELT - FRONT
14	-----	2	SCREW, FLAT HEAD SOCKET CAP M6X12
15	-----	2	ROD, HEXAGONAL
16	-----	2	WASHER, SPRING M8
17	-----	2	WASHER, FLAT 10.1 ID x 20 OD x 4MM
18	-----	2	BOLT, HEX HEAD - M8x20
19	80100847	1	PIN, BELT GUIDE
20	-----	2	LOCKNUT HEX M8
21	80101248	1	COVER BELT - R.H.
22	80101247	1	COVER BELT - L.H.
23	-----	1	BOLT, HEX FLANGE - M6x12
24	-----	1	BOLT, HEX FLANGE M6x16
25	-----	2	SCREW, HEX HEAD - M6x16
26	-----	2	WASHER, SPRING M6
27	-----	4	WASHER, FLAT M6 x 1.5mm
28	-----	2	WASHER, FLAT M6 x 1.2mm
100	80107182		KIT, DISCHARGE GUARD -(Incl. Ref. Nos. 1, 2, 3, 4 & 5)

Drive Belt (38") Group

Note: Unless noted otherwise, use the standard torque specifications

Mfg. No: 2691870-00

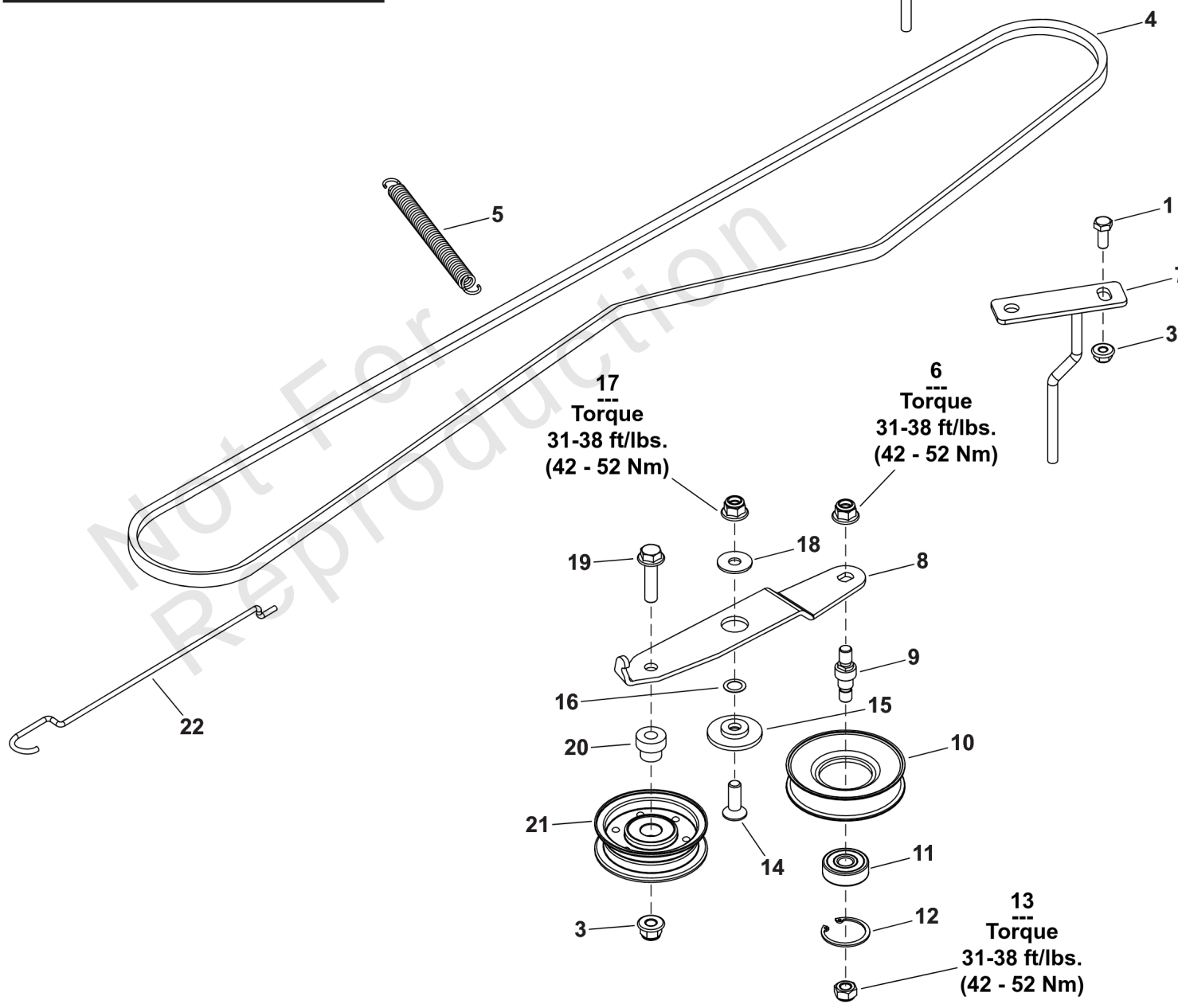
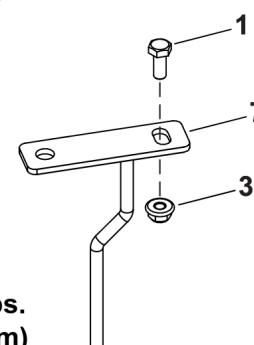
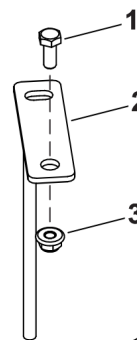
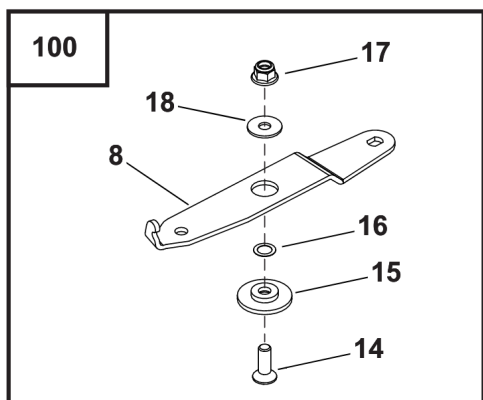

Drive Belt (38") Group

REF NO	PART NO	QTY	DESCRIPTION
1	-----	2	BOLT, HEX HEAD - M8x20
2	80101266	1	GUIDE, PIN BELT - L.H.
3	-----	2	LOCKNUT HEX FLANGE M8
4	80100821	1	V-BELT, LG4-890
5	80101151	1	SPRING, EXTENSION
6	80100707	2	LOCKNUT HEX FLANGE M10x1.25
7	80101265	1	GUIDE, PIN BELT - R.H.
8	80101263	1	ARM, TENSION - DRIVING -(Included with Ref. No. 100)
9	80101150	1	SHAFT, TENSION PULLEY
10	80100876	1	PULLEY TENSION RER
11	80100806	1	BEARING 6301-2RS
12	-----	1	CIRCLIP INTERNAL 37MM
13	80100706	1	LOCKNUT HEX M10x1.25
14	-----	1	SCREW, CSKCAP - M10x30 -(Included with Ref. No. 100)
15	80101262	1	BUSH, DRIVING - TENSION ARM -(Included with Ref. No. 100)
16	-----	1	WASHER -(Included with Ref. No. 100)
17	-----	1	NUT, FLANGE LOCKING - M10 -(Included with Ref. No. 100)
18	-----	1	WASHER, FLAT -(Included with Ref. No. 100)
19	80100665	1	BOLT, HEX FLANGE
20	80101295	1	BUSH, TENSION PULLEY
21	80101302	1	PULLEY, TENSION
22	80101261	1	PULL ROD
100	80107692		KIT, DRIVING TENSION ARM ASSY FER -(Incl. Ref. Nos. 8, 14, 15, 16, 17 & 18)

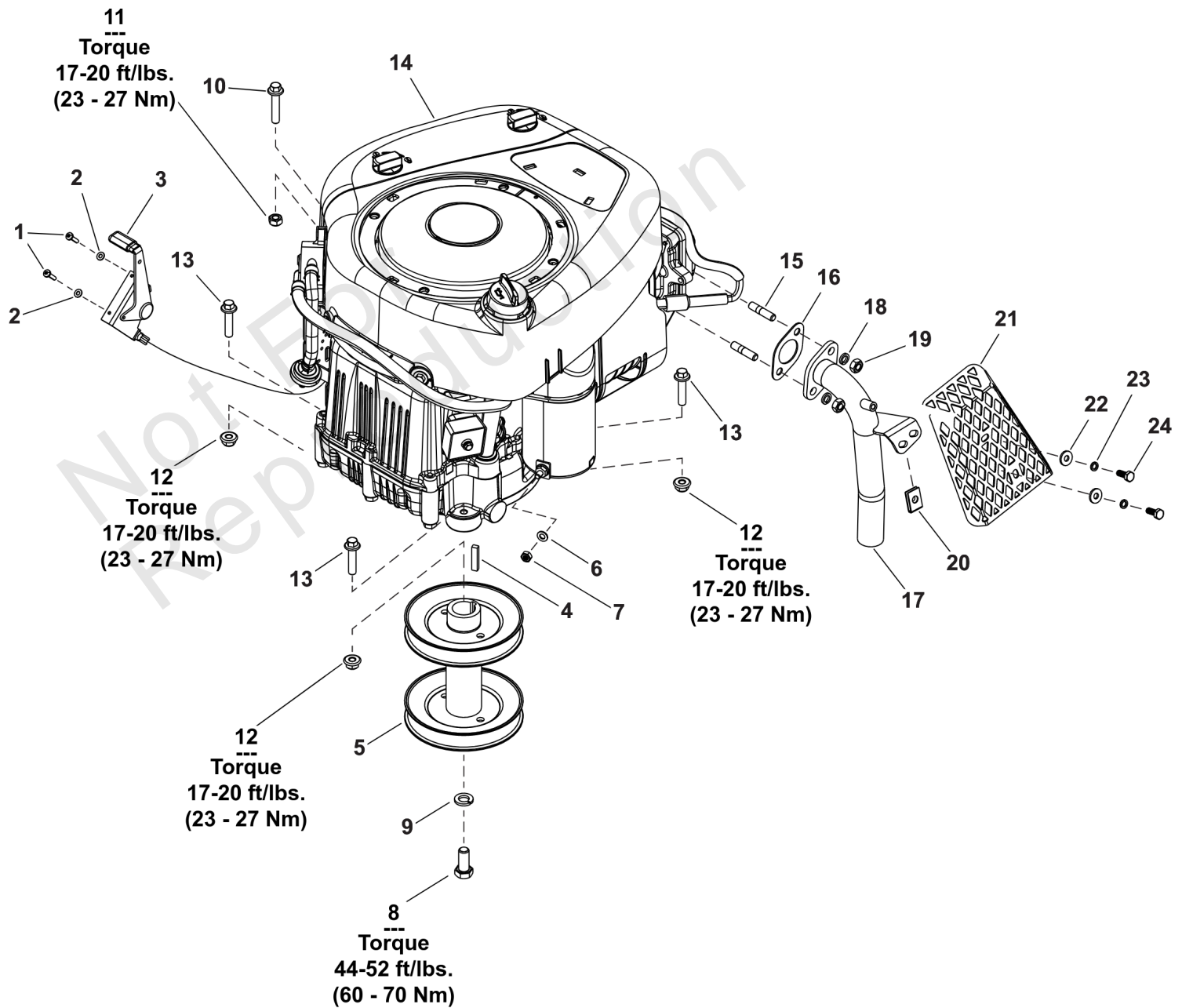
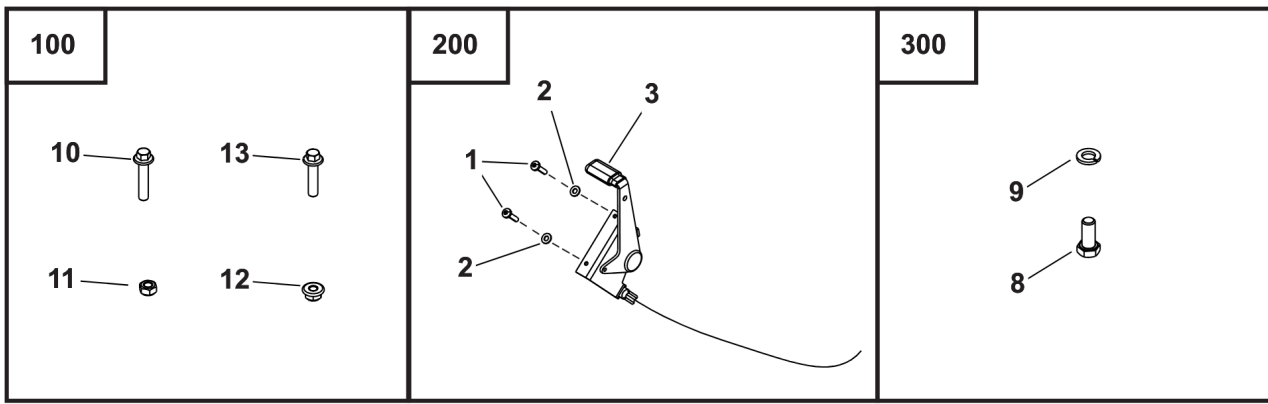

Engine & Controls Group

REF NO	PART NO	QTY	DESCRIPTION
1	-----	2	SCREW, PHILLIPS PAN HEAD -(Included with Ref. No. 200)
2	-----	2	WASHER, FLAT - M4 -(Included with Ref. No. 200)
3	-----	1	THROTTLE CABLE
4	80100869	1	KEY FLAT 6.35x30
5	80101326	1	PULLEY, DRIVE
6	-----	1	WASHER, FLAT M6 x 1.2mm
7	-----	1	NUT, HEX - 1/4"-20 UNC
8	-----	1	BOLT, HEX HEAD -(Included with Ref. No. 300)
9	-----	1	WASHER, SPRING -(Included with Ref. No. 300)
10	-----	1	BOLT, HEX FLANGE M8x40 -(Included with Ref. No. 100)
11	-----	1	LOCKNUT HEX M8 -(Included with Ref. No. 100)
12	-----	13	LOCKNUT HEX FLANGE M8 -(Included with Ref. No. 100)
13	-----	3	BOLT, HEX FLANGE M8X35 -(Included with Ref. No. 100)
14	31R777-0015-B5	1	ENGINE, 15.5HP 500cc - ENGINE SERIES 4175X
15	80101299	2	STUD, DOUBLE ENDED - 5/16"-18
16	80101298	1	GASKET, EXHAUST B&S ENGINE
17	80101322	1	MANIFOLD, EXHAUST
18	-----	2	WASHER, SPRING 5/16"
19	-----	2	NUT, HEX - 5/16"-18 UNC-2B
20	-----	1	U-NUT M6
21	80101301	1	GUARD MUFFLER
22	-----	2	WASHER, FLAT M6 x 1.5mm
23	-----	2	WASHER, SPRING M6
24	-----	2	SCREW, HEX HEAD - M6x16
100	80104192		KIT, HARDWARE ENGINE -(Incl. Ref. Nos. 10, 11, 12 & 13)
200	80104191		KIT, THROTTLE CABLE ASSY FER -(Incl. Ref. Nos. 1, 2 & 3)
300	80104193		KIT, HARDWARE ENGINE PULLEY -(Incl. Ref. Nos. 8 & 9)

Front Axle Group

Note: Unless noted otherwise, use the standard torque specifications

Mfg. No: 2691870-00

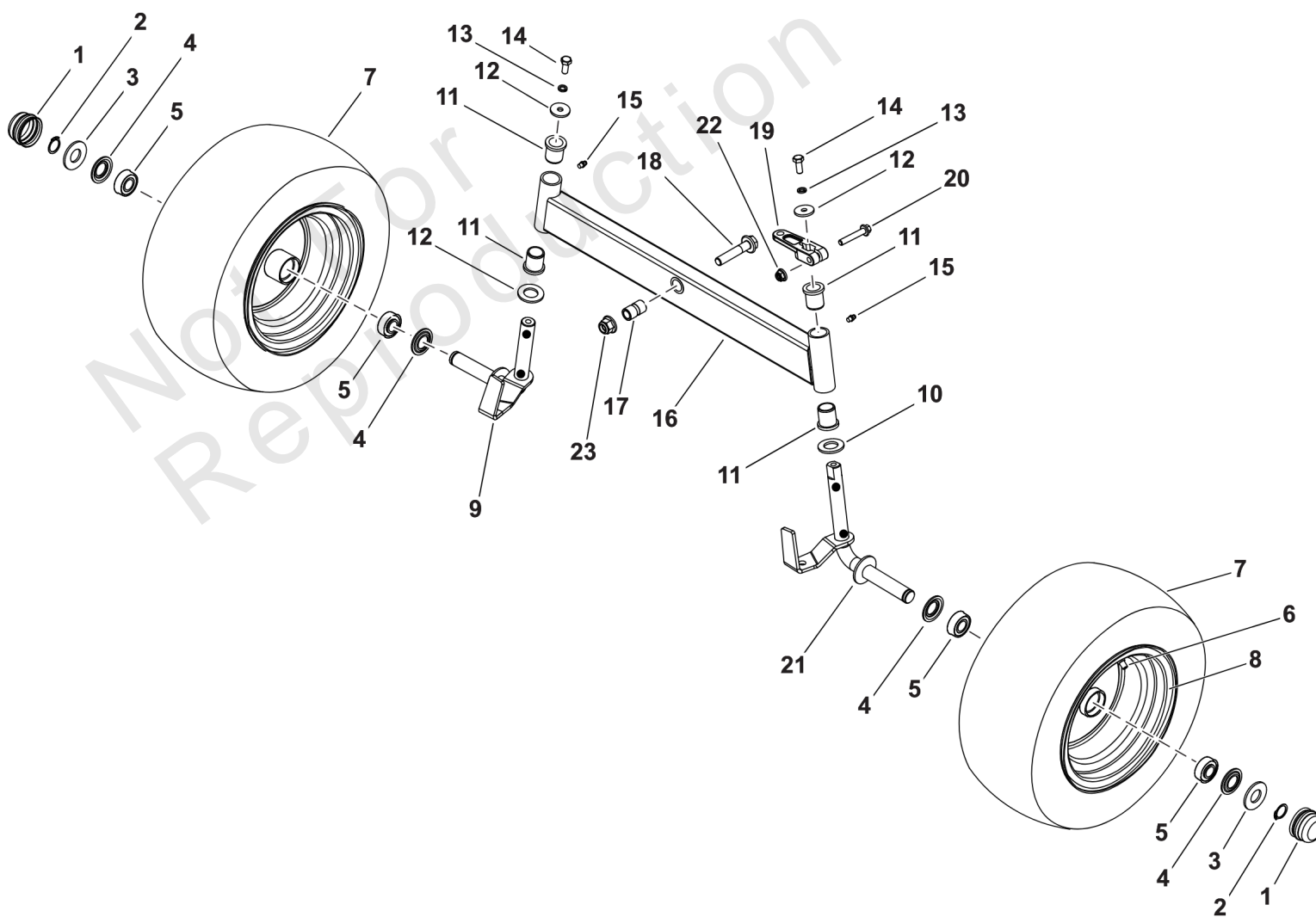
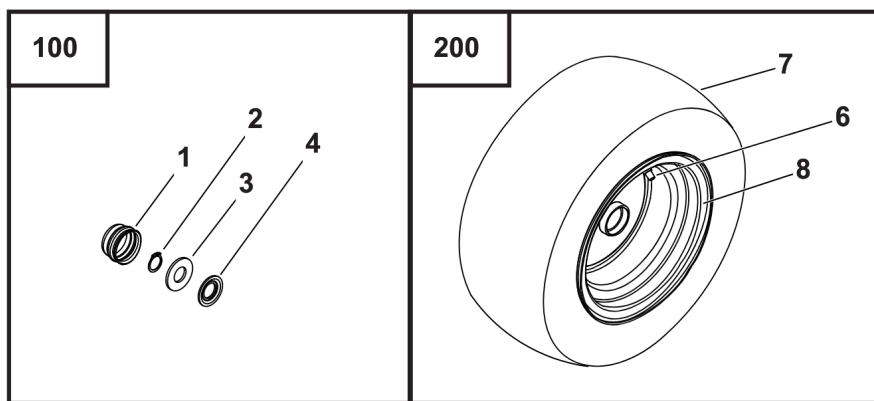

Front Axle Group

REF NO	PART NO	QTY	DESCRIPTION
1	-----	2	HUB COVER -(Included with Ref. No. 100)
2	80100778	2	CIRCLIP EXTERNAL 19 DIA -(Included with Ref. No. 100)
3	-----	2	WASHER, FLAT -(Included with Ref. No. 100)
4	-----	4	WASHER, BEARING RETAINER - FRONT WHEEL -(Included with Ref. No. 100)
5	80100804	4	BEARING
6	-----	2	CYCLE VALVE, FRONT TIRE -(Included with Ref. No. 200)
7	-----	2	TIRE, FRONT -(Included with Ref. No. 200)
8	-----	2	RIM, FRONT WHEEL -(Included with Ref. No. 200)
9	80101186	1	STUB AXLE, L.H. FRONT
10	-----	2	WASHER, FLAT 20.5ID X 37OD X 2.5
11	-----	4	BUSH STEERING
12	-----	2	WASHER, CLUTCH
13	-----	2	WASHER, SPRING M8
14	-----	2	BOLT, HEX HEAD M8 x 20
15	80100813	2	GREASE NIPPLE, M6
16	80101184	1	FRONT AXLE SUB-ASSEMBLY
17	80100886	1	BUSH PIVOT
18	80100677	1	BOLT, HEX FLANGE
19	-----	1	TURNING ARM
20	-----	1	BOLT, HEX FLANGE - M8x45
21	80101185	1	STUB AXLE, R.H. FRONT
22	-----	1	LOCKNUT HEX FLANGE M8
23	-----	1	LOCKNUT HEX FLANGE M12X1.25
100	80102234		KIT, HUBCAP & HARDWARE, FRONT WHEEL -(Incl. Ref. Nos. 1, 2, 3 & 4)
200	80100628		KIT, FRONT WHEEL ASSY -(Incl. Ref. Nos. 6, 7 & 8)

Fuel Tank Group

Note: Unless noted otherwise, use the standard torque specifications

Mfg. No: 2691870-00

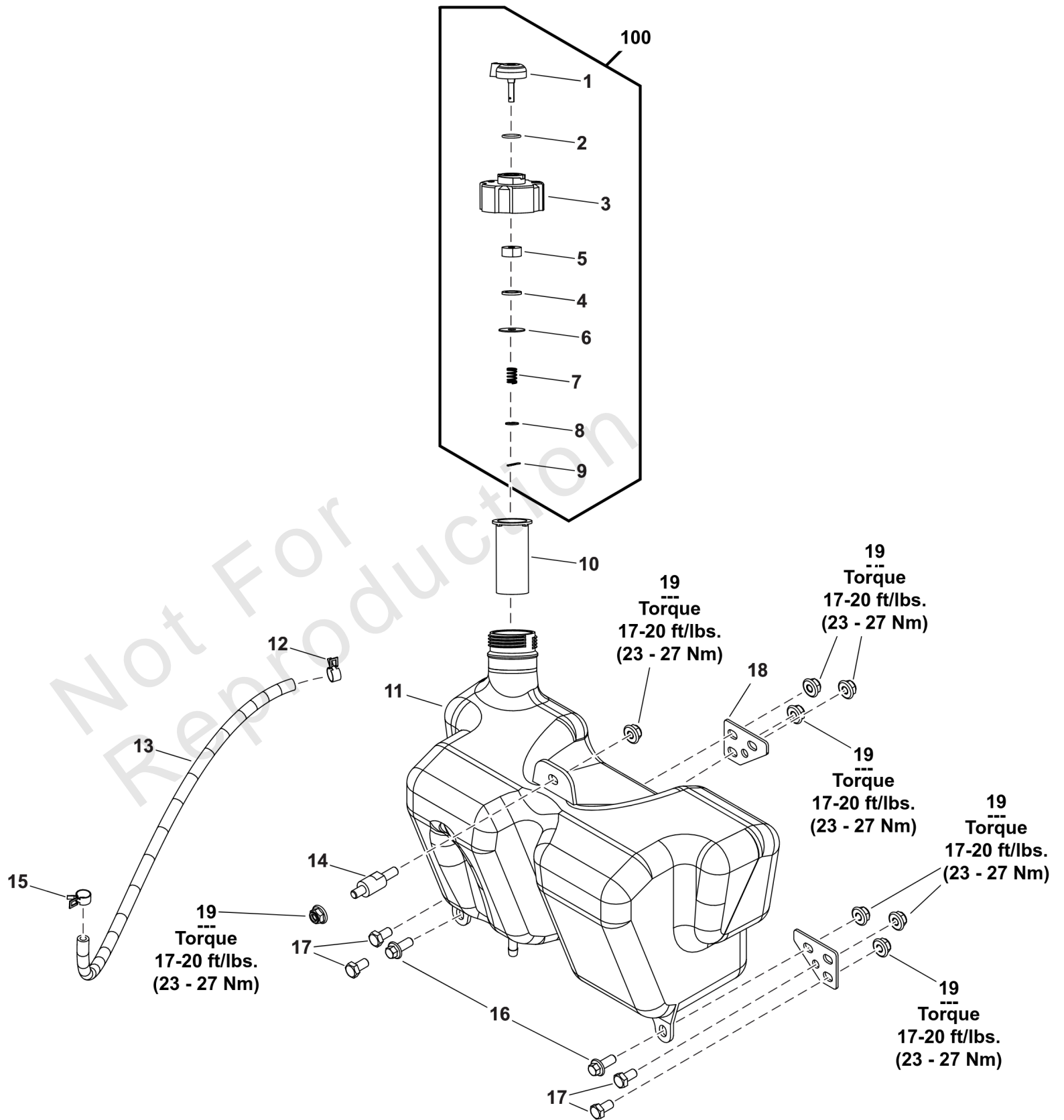

Fuel Tank Group

REF NO	PART NO	QTY	DESCRIPTION
1	-----	1	LEVER, FUEL TANK CAP -(Included with Ref. No. 20)
2	-----	1	O-RING -(Included with Ref. No. 20)
3	-----	1	CAP, FUEL TANK -(Included with Ref. No. 20)
4	-----	1	FILTER, FUEL TANK CAP -(Included with Ref. No. 20)
5	-----	1	SEAL, FUEL TANK CAP -(Included with Ref. No. 20)
6	-----	1	GASKET, FUEL CAP -(Included with Ref. No. 20)
7	-----	1	SPRING, FUEL TANK CAP -(Included with Ref. No. 20)
8	-----	1	WASHER, FLAT - M5 -(Included with Ref. No. 20)
9	-----	1	SPLIT PIN -(Included with Ref. No. 20)
10	80101335	1	FILTER, FUEL - TANK INLET
11	80101307	1	TANK, FUEL
12	80101289	1	CLIP, 10mm ID SPRING - FUEL HOSE
13	-----	1	HOSE, FUEL
14	-----	1	BOLT, NON STANDARD - FUEL TANK
15	80101290	1	CLIP, 10mm DIA DOUBLE WIRE SPRING - FUEL HOSE
16	-----	2	BOLT, HEX FLANGE M8 x 20
17	-----	4	BOLT, HEX HEAD - M8x16
18	-----	2	BRACKET, SUPPORT - FUEL TANK
19	-----	8	LOCKNUT HEX FLANGE M8
100	80100853	1	CAP ASSEMBLY, FUEL TANK -(Incl. Ref. Nos. 1, 2, 3, 4, 5, 6, 7, 8 & 9)

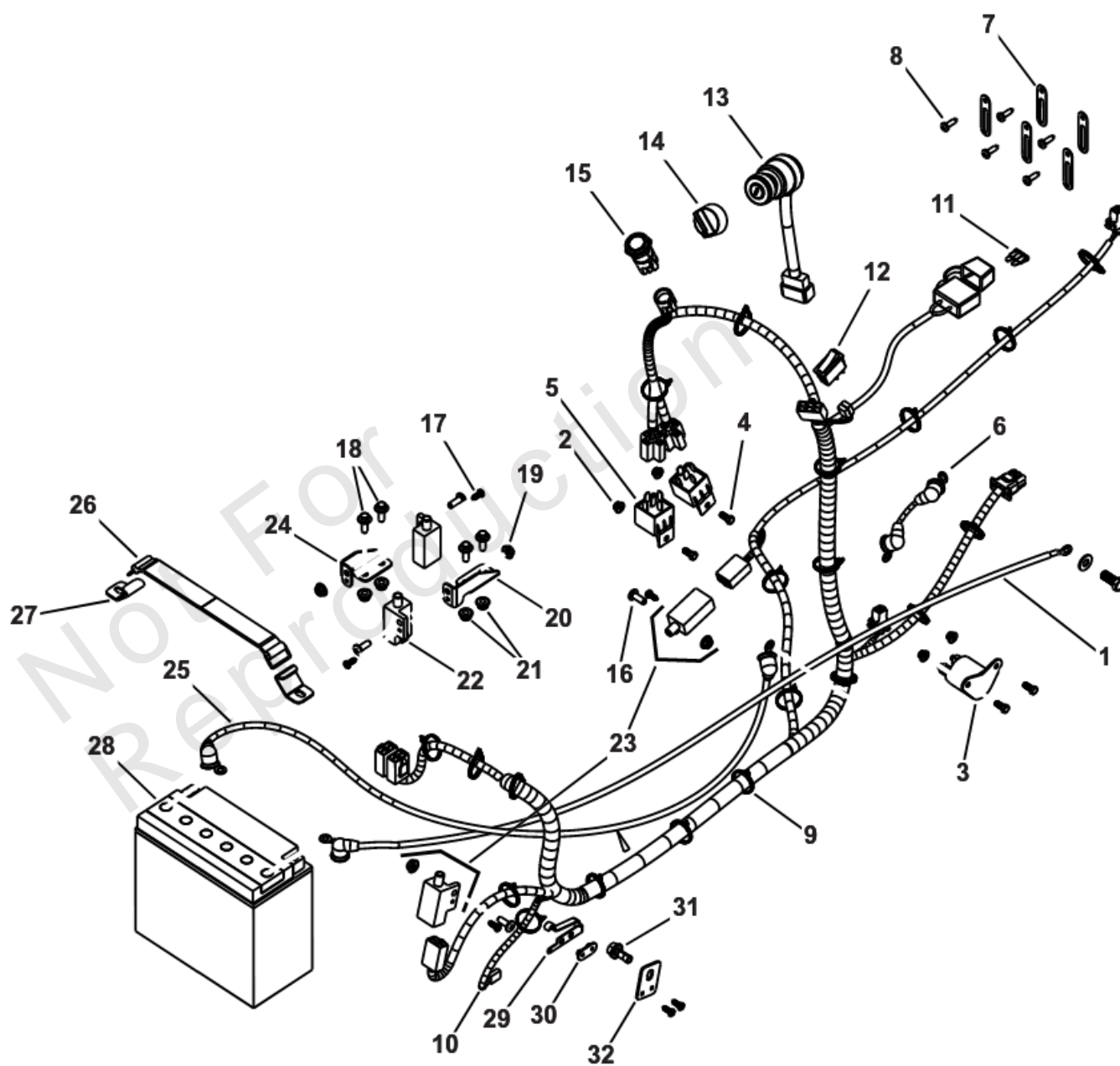

H Electrical Group

REF NO	PART NO	QTY	DESCRIPTION
1	80107632	1	WIRING HARNESS, GROUND
2	-----	4	LOCKNUT, HEX FLANGE - M5
3	80101305	1	RELAY, STARTING ST188F
4	-----	4	SCREW, HEX HEAD - M5x16
5	80100817	2	RELAY - JD1914
6	-----	1	WIRING HARNESS, POWER
7	-----	5	CLIP, IGNITION COIL
8	80122618	5	HARNESS, ENGINE CONNECTOR
9	-----	20	CABLE TIE 3.2 x 140mm
10	80107636	1	HARNESS ASSEMBLY
11	-----	1	FUSE, 15 AMP-32V
12	80101313	1	SWITCH, WIRING
13	80101034	1	SWITCH, ROTARY WITH KEY
14	80100854	1	KEY
15	80107638	1	SWITCH, RE-SETTING
16	-----	4	SCREW, PHILIPS FLAT HEAD M6X16
17	-----	6	SCREW, PAN HEAD
18	-----	4	BOLT, HEX FLANGE M6X16
19	-----	4	NUT HEX FLANGE M6
20	-----	1	BRACKET, SWITCH - R.H.
21	-----	4	LOCKNUT HEX FLANGE M6
22	80101030	2	SWITCH SEAT DOUBLE NC
23	80101033	2	SWITCH PUSH O/C -(BRAKE, PTO)
24	-----	1	BRACKET, SWITCH - L.H.
25	80119962	1	BATTERY CABLE
26	-----	1	STRAP BATTERY
27	-----	2	HOOK, BATTERY TIE DOWN
28	-----	1	BATTERY 12V 18Ah
29	-----	1	BRACKET, CONTACT - SWITCH
30	-----	1	INSULATING STRIP
31	-----	1	BOLT, HEX FLANGE - M8x16
32	-----	1	BRACKET, SWITCH

H Frame FER Group

Note: Unless noted otherwise, use the standard torque specifications

Mfg. No: 2691870-00

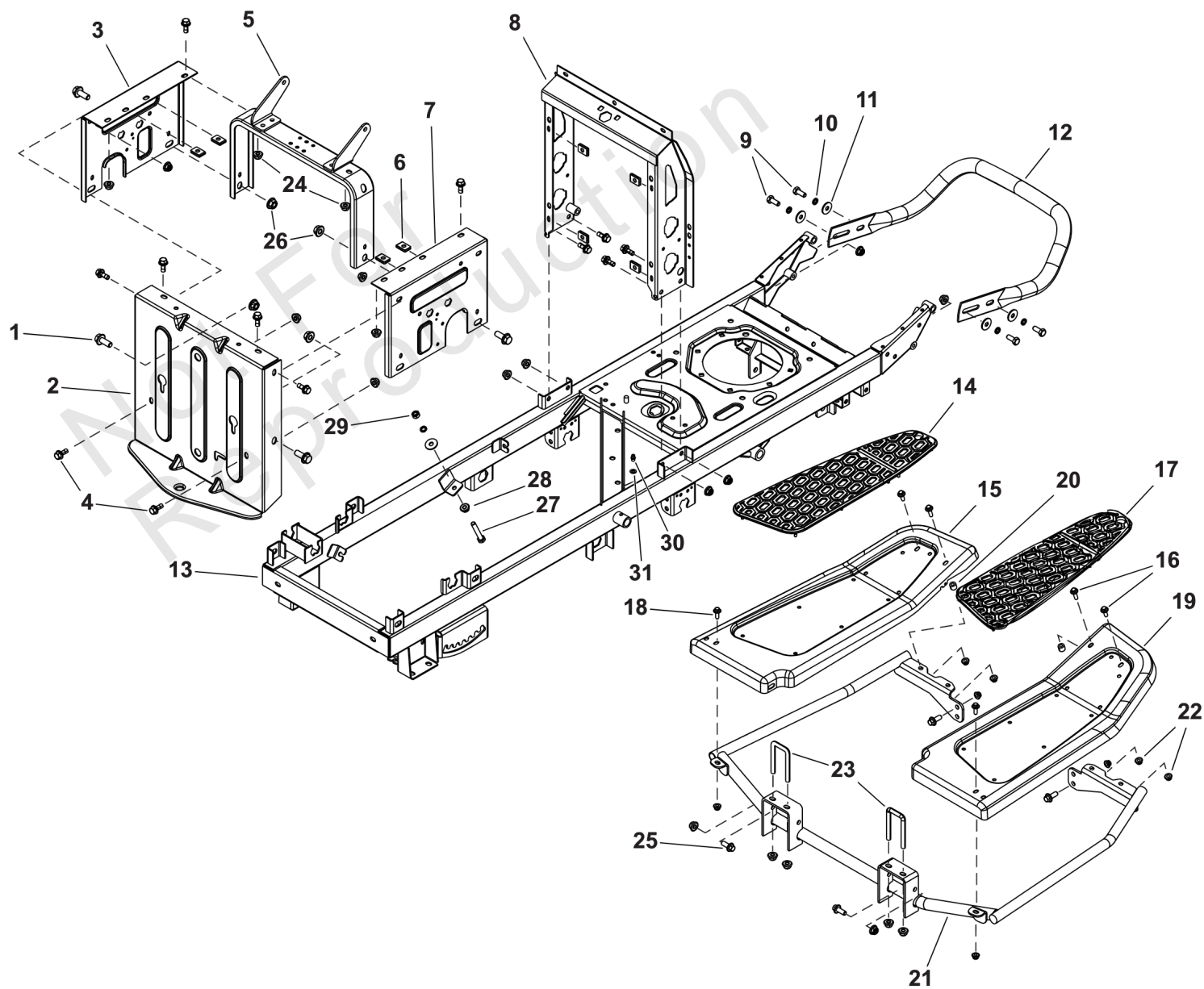
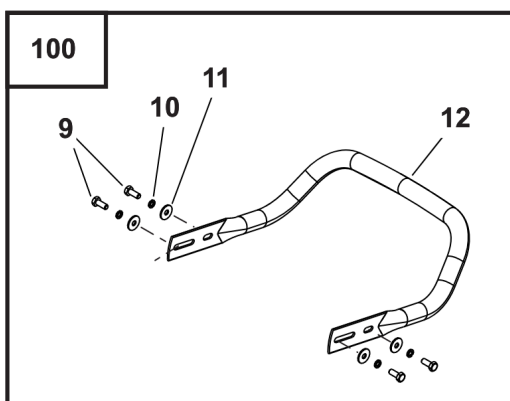

H Frame FER Group

REF NO	PART NO	QTY	DESCRIPTION
1	-----	4	BOLT, HEX FLANGE M10 x 1.25 x 25
2	-----	1	REAR BRACKET
3	-----	1	LEFT BRACKET
4	-----	12	BOLT, HEX FLANGE - M8x16
5	-----	1	SEAT BRACKET
6	-----	8	U-NUT M6
7	-----	1	RIGHT BRACKET
8	-----	1	STEERING BRACKET
9	-----	4	BOLT, HEX HEAD M8 x 20 -(Included with Ref. No. 100)
10	-----	5	WASHER, SPRING M8 -(Included with Ref. No. 100)
11	-----	5	WASHER, FLAT 8.4ID x 24OD x 2MM -(Included with Ref. No. 100)
12	-----	1	BUMPER, FRONT -(Included with Ref. No. 100)
13	80101269	1	FRAME
14	80101176	1	COVER, FOOTBOARD - L.H.
15	80101175	1	FOOTBOARD, L.H.
16	-----	2	BOLT, HEX FLANGE - M6x16
17	80101178	1	COVER, FOOTBOARD - R.H.
18	-----	4	BOLT, HEX FLANGE M6x16
19	80101174	1	FOOTBOARD, R.H.
20	80101177	2	BUSH, SPACER - FOOTBOARD
21	-----	1	BRACKET, FOOT SUPPORT
22	-----	8	LOCKNUT HEX FLANGE M6
23	80101173	2	U-BOLT, M8
24	-----	2	LOCKNUT HEX FLANGE M8
25	-----	4	BOLT, HEX FLANGE M8 x 20
26	-----	4	NUT HEX FLANGE 10 x 1.25
27	-----	1	BOLT, HEX - M8x50
28	-----	1	NUT HEX M8
29	-----	1	NUT HEX M8
30	80100813	1	GREASE NIPPLE, M6
31	-----	1	WASHER, FLAT M6 x 1.2mm
100	80107693		KIT, BUMPER & HARDWARE FER -(Incl. Ref. Nos. 9, 10, 11 & 12)

H Hood Cover Group

Note: Unless noted otherwise, use the standard torque specifications

Mfg. No: 2691870-00

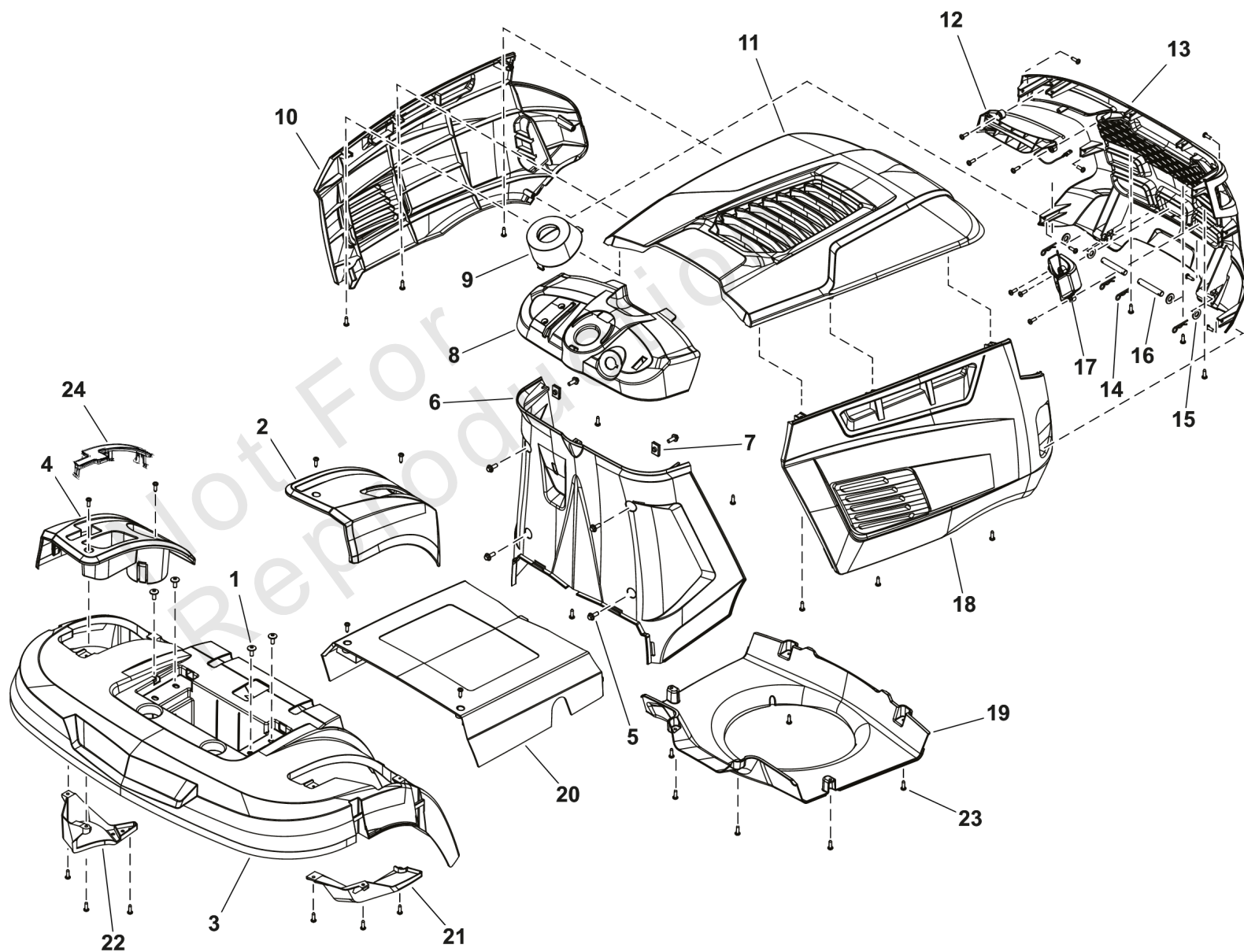

H Hood Cover Group

REF NO	PART NO	QTY	DESCRIPTION
1	-----	4	SCREW, FLAT HEAD SOCKET CAP M6x16
2	80105904	1	COVER, LIFT
3	80101226	1	COVER, REAR - FER
4	80105909	1	COVER, SHIFT
5	-----	6	BOLT, HEX FLANGE M6x16
6	-----	1	COVER, STEERING COLUMN
7	-----	2	U-NUT M6
8	80107508	1	DASHBOARD
9	80105907	1	CAP, STEERING SHAFT
10	80107511	1	PANEL, ENGINE - L.H.
11	80107512	1	COVER/HOOD, ENGINE
12	80107515	1	HEADLIGHT ASSEMBLY, LED
13	80107513	1	COVER, FRONT - ENGINE
14	80100954	4	R CLIP 10 DIA SHAFT X 2mm DIA
15	-----	4	WASHER, FLAT M10 X 2
16	80101241	2	PIN
17	80107514	1	HEADLIGHT ASSEMBLY, LED - RHS
18	80107509	1	PANEL, ENGINE - R.H.
19	80107510	1	SHROUD, ENGINE
20	80107592	1	COVER, FLOOR
21	80101228	1	COVER PLATE, RIGHT
22	80101229	1	COVER PLATE, LEFT
23	-----	43	SCREW, ST No.10x16 PH PAN HD TYPE AB
24	80126619	1	COVER PLATE

Lift (38") Group

Note: Unless noted otherwise, use the standard torque specifications

Mfg. No: 2691870-00

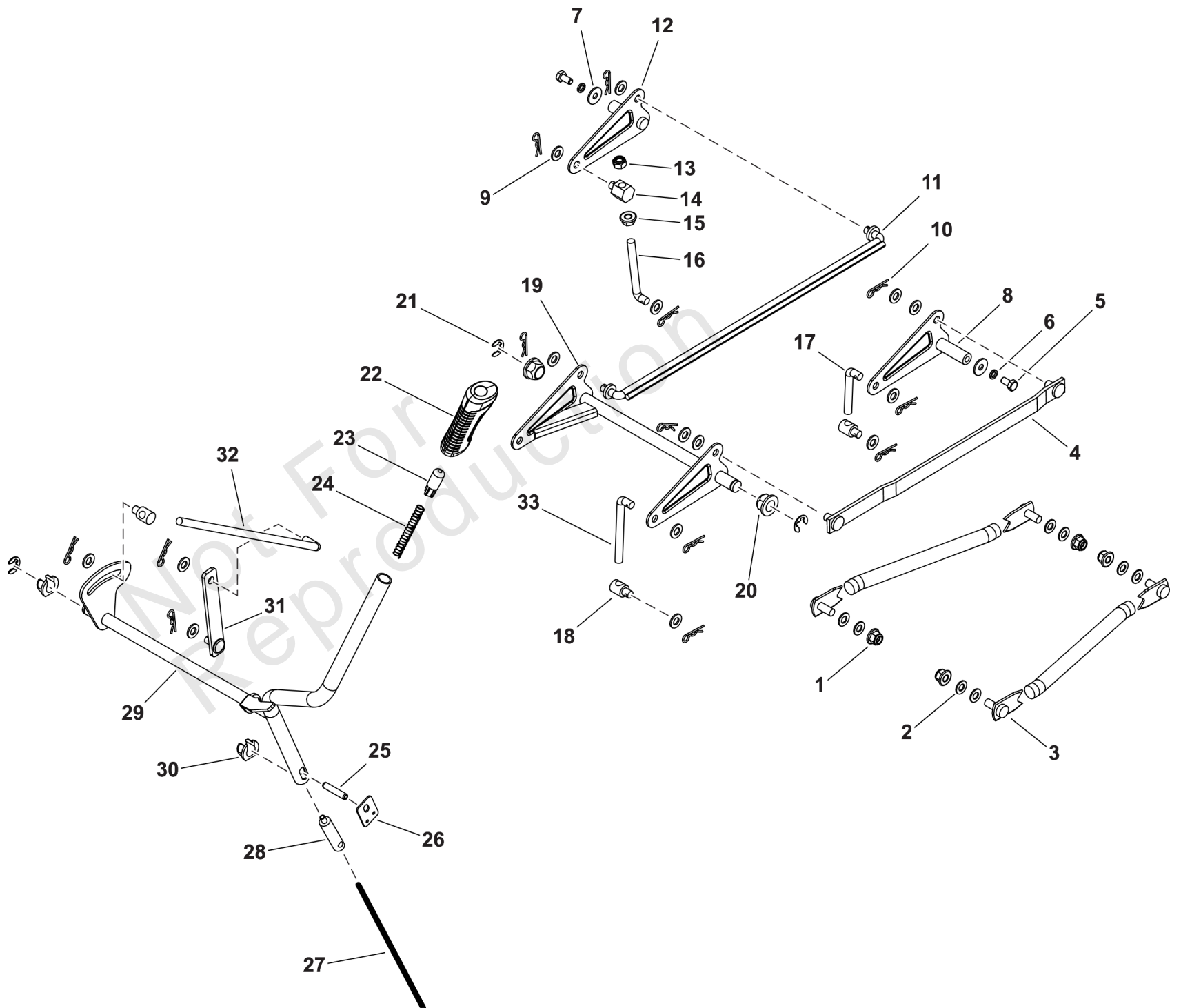

Lift (38") Group

REF NO	PART NO	QTY	DESCRIPTION
1	80100707	4	LOCKNUT HEX FLANGE M10x1.25
2	80100862	8	WASHER, FLAT 10.2ID x 19OD x 1.6MM
3	80101215	2	ROD, FRONT
4	80101279	1	PUSH ROD ASSEMBLY, R.H.
5	-----	2	BOLT, HEX HEAD - M8x16
6	-----	2	WASHER, SPRING M8
7	-----	2	WASHER, FLAT 8.4ID x 24OD x 2MM
8	80101217	1	FRONT ARM, R.H.
9	-----	15	WASHER, FLAT M10 X 2
10	80100954	13	R CLIP 10 DIA SHAFT X 2mm DIA
11	80101218	1	PUSH ROD ASSEMBLY, L.H.
12	-----	1	FRONT ARM, L.H.
13	80100706	1	LOCKNUT HEX M10x1.25
14	80101209	1	PIN, ADJUSTING
15	-----	1	NUT HEX FLANGE 10 x 1.25
16	80101210	1	ROD, ADJUSTING - FRONT L.H.
17	80100980	1	ROD ADJUSTING
18	80100979	3	PIN ADJUSTING
19	80101219	1	REAR ARM ASSEMBLY
20	80100978	2	BUSH HEXAGON
21	-----	3	E-CLIP 12 DIA x 1.2mm
22	80100968	1	HANDLE LIFT
23	80100967	1	BUTTON LIFT
24	80101214	1	SPRING, COMPRESSION - BUTTON
25	80100802	1	PIN, SPRING
26	80101223	1	RIVET JOINT
27	80101222	1	CABLE
28	80101221	1	PIN
29	80101224	1	LEVER ASSEMBLY - LIFT
30	80100958	2	BUSH OPEN SNAP-ON
31	80101220	1	LINK, L.H.
32	80101213	1	ROD, LIFTING
33	80101212	1	ROD, ADJUSTING

Muffler Shield Group

Note: Unless noted otherwise, use the standard torque specifications

Mfg. No: 2691870-00

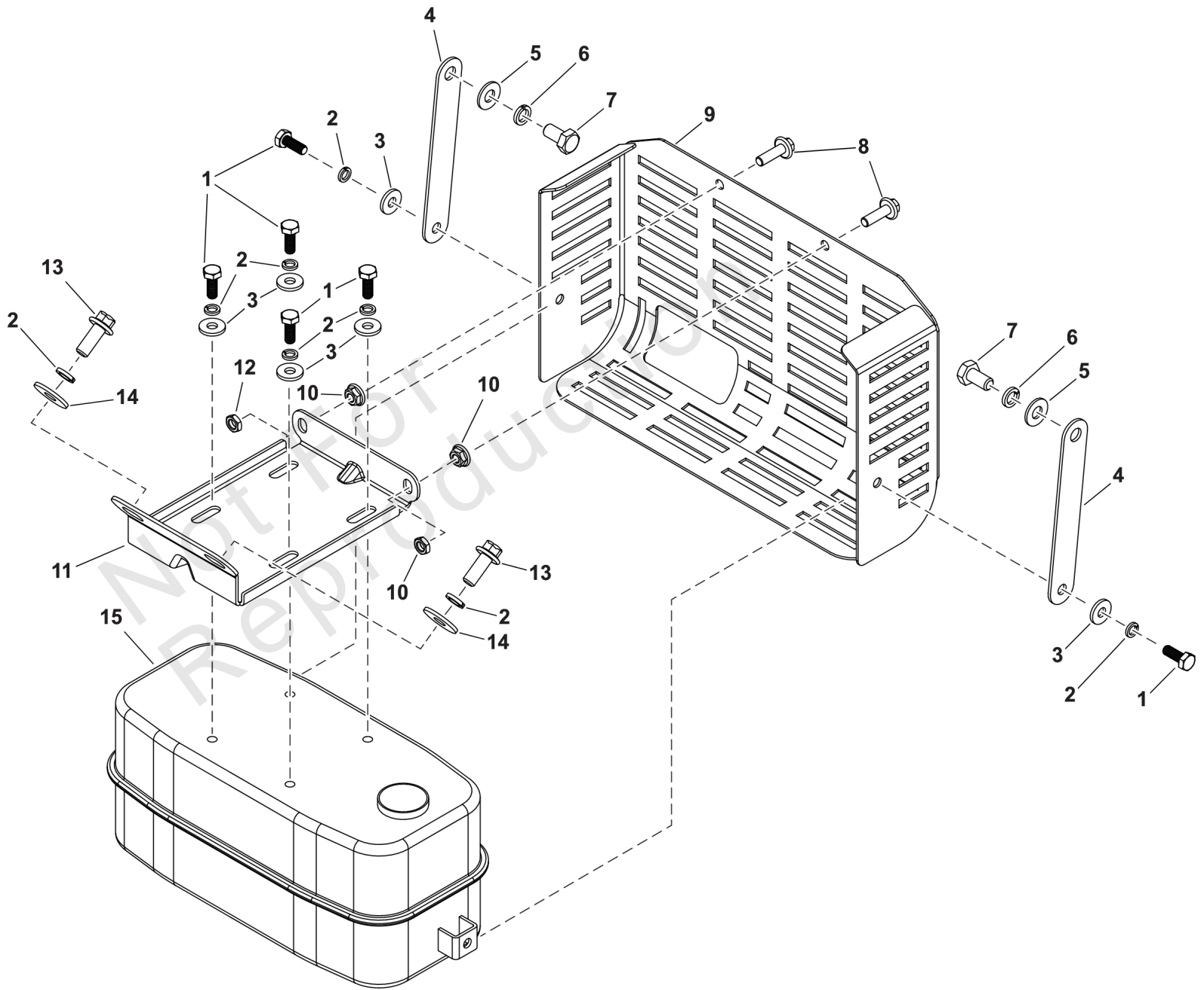

Muffler Shield Group

REF NO	PART NO	QTY	DESCRIPTION
1	-----	6	SCREW, HEX HEAD - M6x16
2	-----	6	WASHER, SPRING M6
3	-----	6	WASHER, FLAT M6 x 1.5mm
4	80101149	2	ROD, CONNECTING - MUFFLER
5	-----	2	WASHER, FLAT M8
6	-----	4	WASHER, SPRING M8
7	-----	2	BOLT, HEX HEAD - M8x16
8	-----	2	BOLT, HEX FLANGE M6x20
9	80101304	1	GUARD, MUFFLER
10	-----	2	NUT HEX FLANGE M6
11	80101148	1	BRACKET, MUFFLER
12	-----	2	LOCKNUT, HEX - M6
13	-----	2	BOLT, HEX FLANGE M8 x 20
14	-----	2	WASHER, FLAT 8.4ID x 24OD x 2MM
15	80101303	1	MUFFLER

Not For Reproduction

Mulch Cover Group

Note: Unless noted otherwise, use the standard torque specifications

Mfg. No: 2691870-00

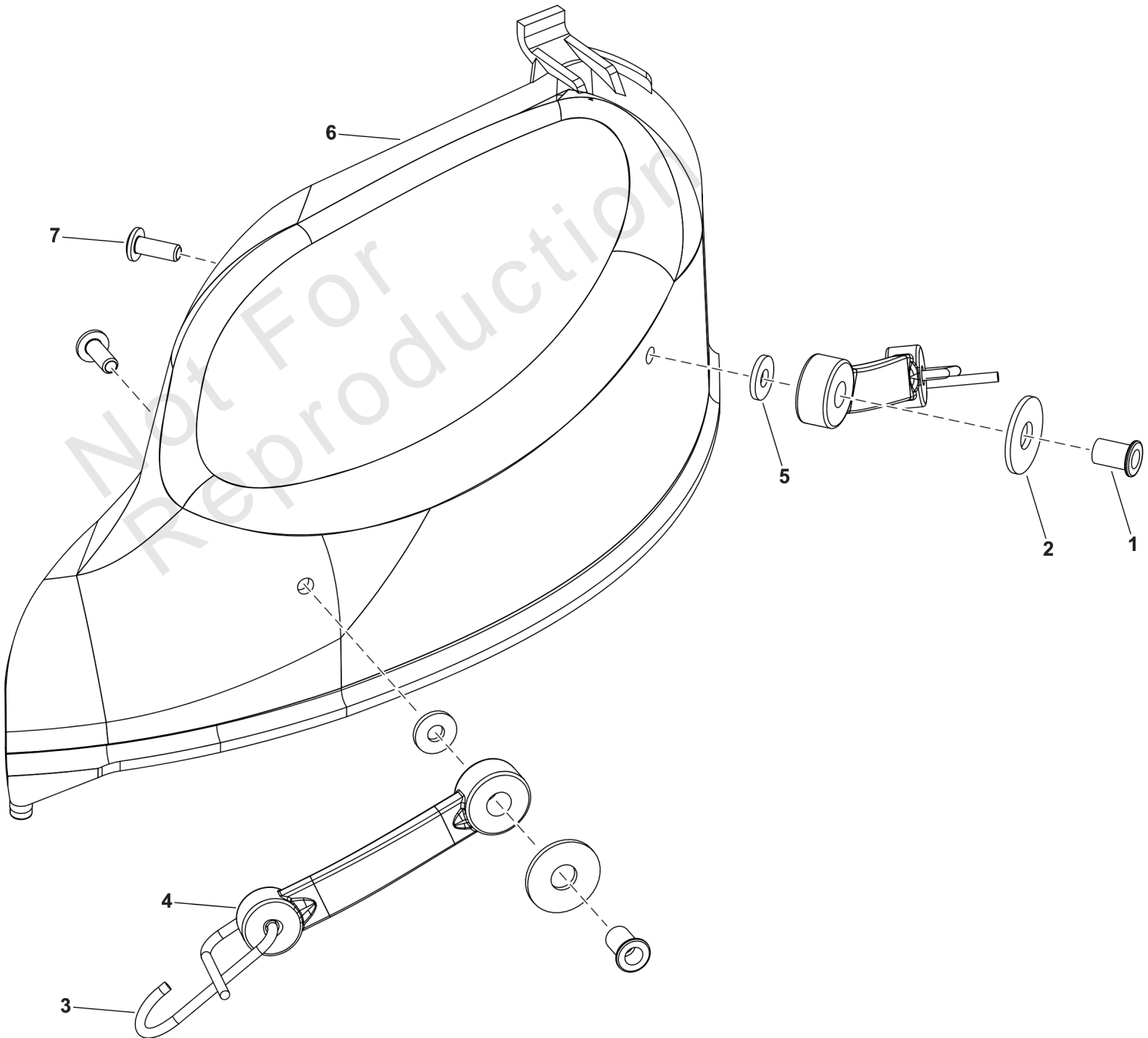
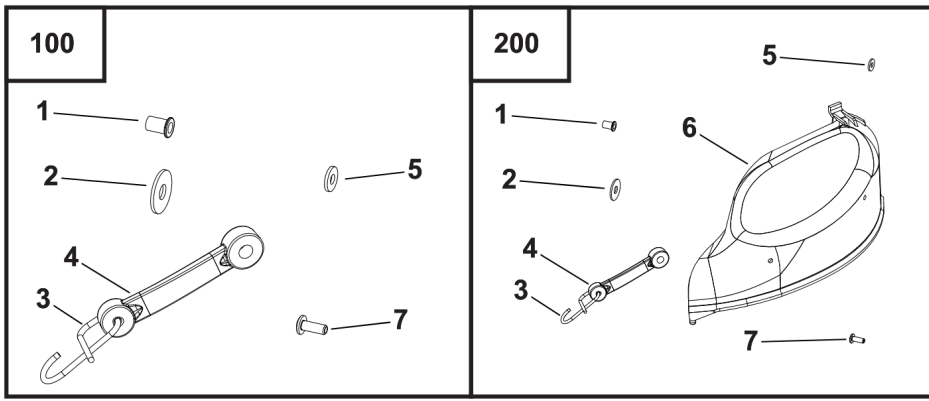

Mulch Cover Group

REF NO	PART NO	QTY	DESCRIPTION
1	-----	2	NUTSERT, M6x13.5 -(Included with Ref. No. 100 & 200)
2	-----	2	WASHER, FLAT -(Included with Ref. No. 100 & 200)
3	-----	2	HOOK, MULCH PLUG -(Included with Ref. No. 100 & 200)
4	-----	2	STRAP, MULCH PLUG -(Included with Ref. No. 100 & 200)
5	-----	2	WASHER, FLAT M6 x 1.5mm -(Included with Ref. No. 100 & 200)
6	-----	1	MULCH PLUG -(Included with Ref. No. 200)
7	-----	2	SCREW, PHILIPS FLAT HEAD M6X16 -(Included with Ref. No. 100 & 200)
100	80107611		KIT, STRAP ASSY MULCH PLUG -(Incl. Ref. Nos. 1, 2, 3, 4, 5 & 7)
200	80106801		KIT, MULCH PLUG & STRAPS -(Incl. Ref. Nos. 1, 2, 3, 4, 5, 6 & 7)

Not For Reproduction

Rear Axle Group

Note: Unless noted otherwise, use the standard torque specifications

Mfg. No: 2691870-00

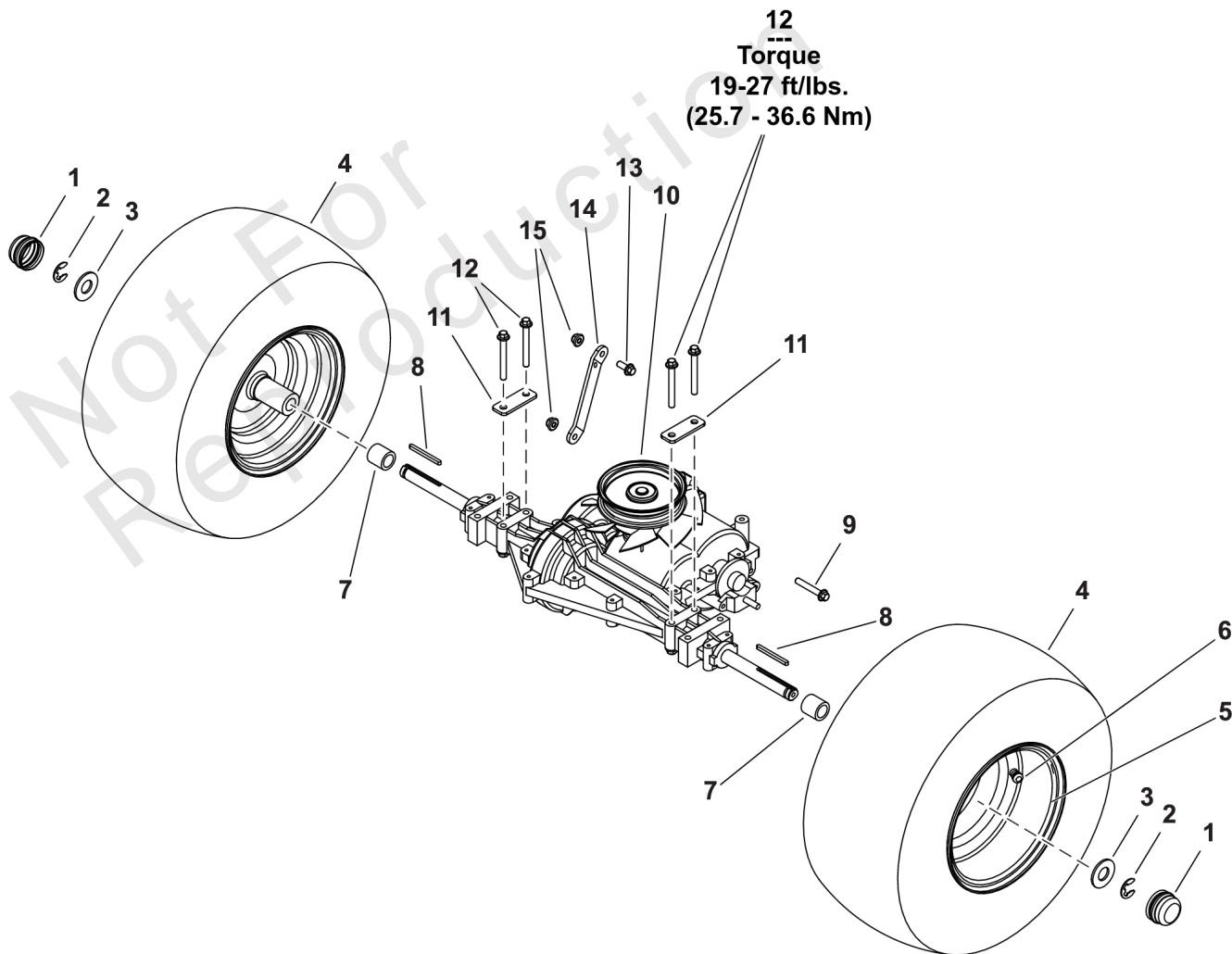
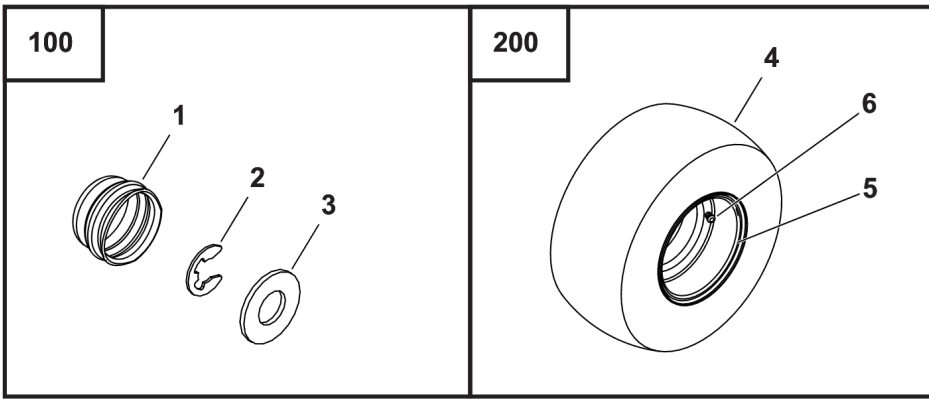

Rear Axle Group

REF NO	PART NO	QTY	DESCRIPTION
1	-----	2	HUB COVER -(Included with Ref. No. 100)
2	-----	2	E CLIP -(Included with Ref. No. 100)
3	-----	2	WASHER, FLAT -(Included with Ref. No. 100)
4	-----	2	TIRE, REAR -(Included with Ref. No. 200)
5	-----	2	RIM, REAR WHEEL -(Included with Ref. No. 200)
6	-----	2	CYCLE VALVE, FRONT TIRE -(Included with Ref. No. 200)
7	80101292	2	TUBE, SPACER - REAR AXLE
8	80101294	2	KEY, FLAT
9	-----	1	BOLT, HEX FLANGE - M8x50
10	80101293	1	TRANSAXLE HYDRO - GEAR T2
11	-----	2	TIE PLATE
12	-----	4	BOLT, HEX HEAD M8X70
13	-----	1	BOLT, HEX FLANGE M8 x 20
14	-----	1	CONNECTING PLATE
15	-----	6	LOCKNUT HEX FLANGE M8
100	80104194		KIT, HUBCAP & HARDWARE, REAR WHEEL -(Incl. Ref. Nos. 1, 2 & 3)
200	80100629		KIT, REAR WHEEL ASSY -(Incl. Ref. Nos. 4, 5 & 6)

Seat Group

Note: Unless noted otherwise, use the standard torque specifications

Mfg. No: 2691870-00

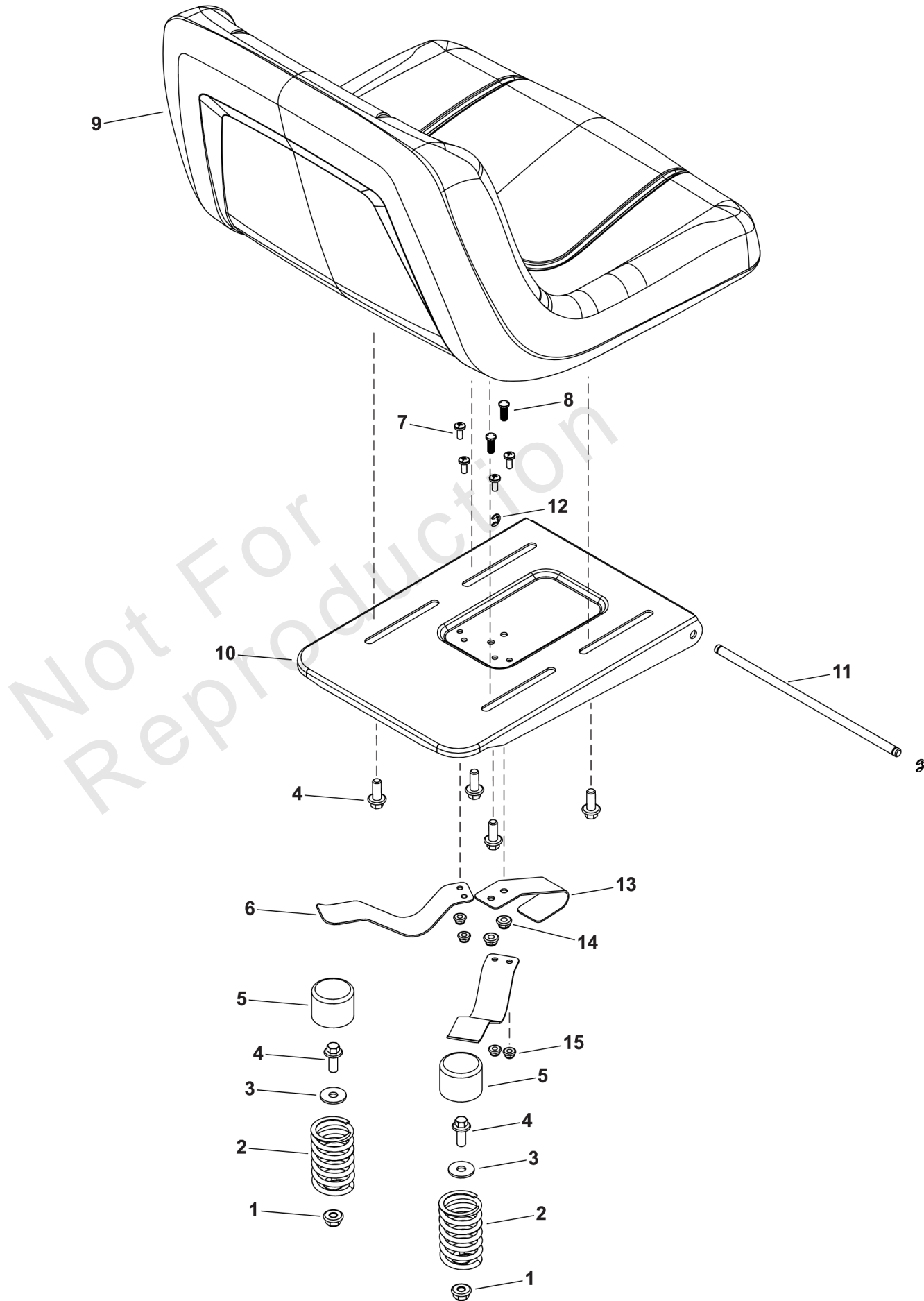

Seat Group

REF NO	PART NO	QTY	DESCRIPTION
1	-----	2	LOCKNUT HEX FLANGE M8
2	80101206	2	SPRING, SEAT
3	-----	2	WASHER, FLAT 8.4ID x 24OD x 2MM
4	-----	6	BOLT, HEX FLANGE M8 x 20
5	80101306	2	CAP, SPRING
6	80101311	2	SPRING, LEAF
7	-----	4	SCREW, PAN HEAD - M5x12
8	-----	2	SCREW, PAN HEAD PHILLIPS - M6 x 16
9	80100966	1	SEAT - 38" AND 42"
10	80101208	1	PLATE, SEAT MOUNTING
11	80101207	1	PIN, SEAT PIVOT
12	-----	2	E CLIP EXTERNAL 6 DIA x 0.8mm
13	80101025	1	CONTACT SEAT SWITCH
14	-----	2	LOCKNUT HEX FLANGE M6
15	-----	4	LOCKNUT, HEX FLANGE - M5

Not For Reproduction

Shift Group

Note: Unless noted otherwise, use the standard torque specifications

Mfg. No: 2691870-00

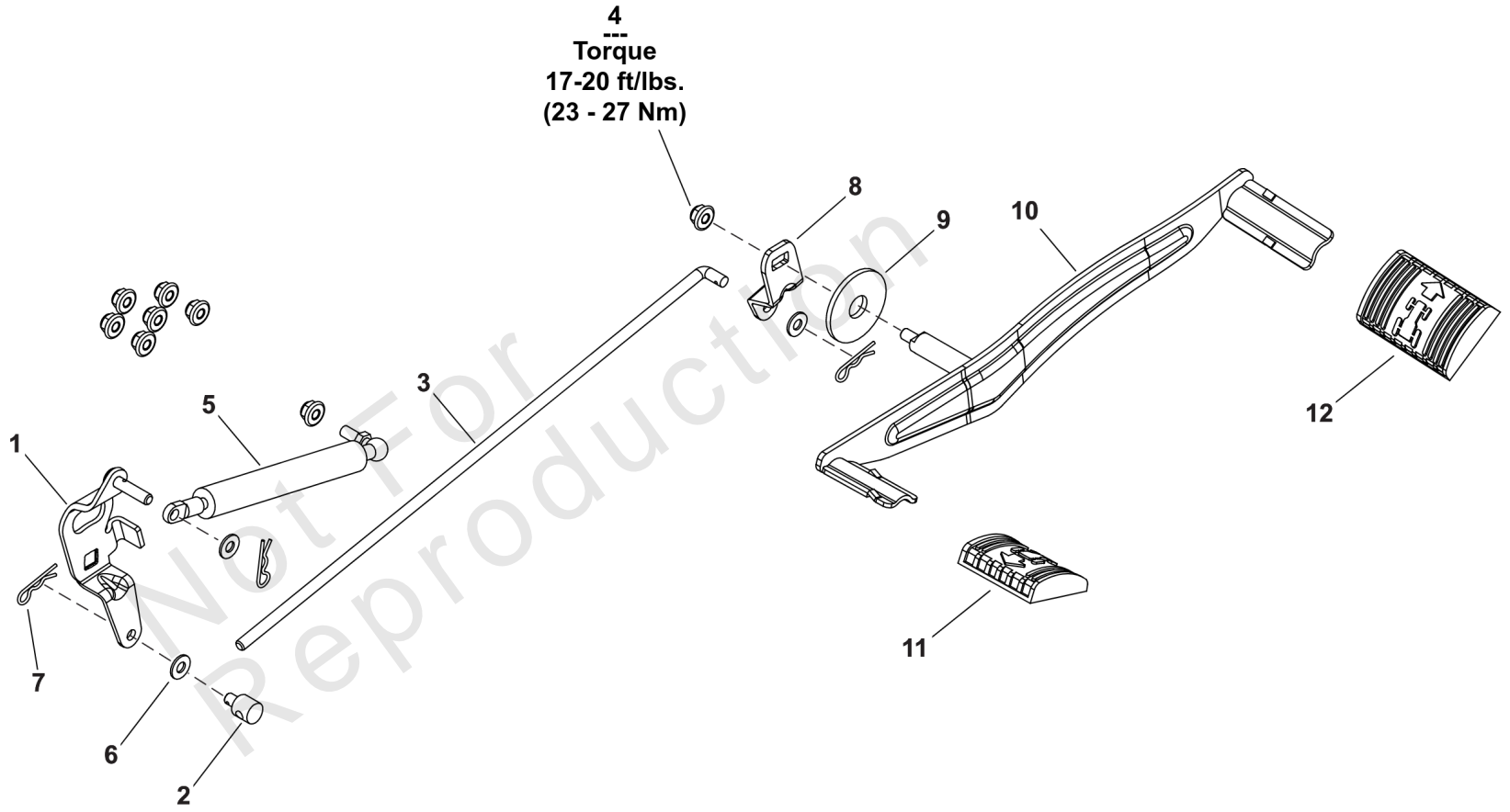

Shift Group

REF NO	PART NO	QTY	DESCRIPTION
1	-----	1	CONTROL ARM
2	80100955	1	PIN GEAR SHIFT
3	80101271	1	ROD, SHIFT
4	-----	8	LOCKNUT HEX FLANGE M8
5	80101291	1	DAMPER
6	-----	3	WASHER, FLAT M8
7	80100954	3	R CLIP 10 DIA SHAFT X 2mm DIA
8	-----	1	BRACKET, SHIFT ARM
9	80101158	1	WASHER, FLAT
10	801001275	1	LEVER, PEDAL
11	80101270	1	PEDAL, REVERSE
12	80101273	1	PEDAL, FORWARD

Not For Reproduction

Steering Group

Note: Unless noted otherwise, use the standard torque specifications

Mfg. No: 2691870-00

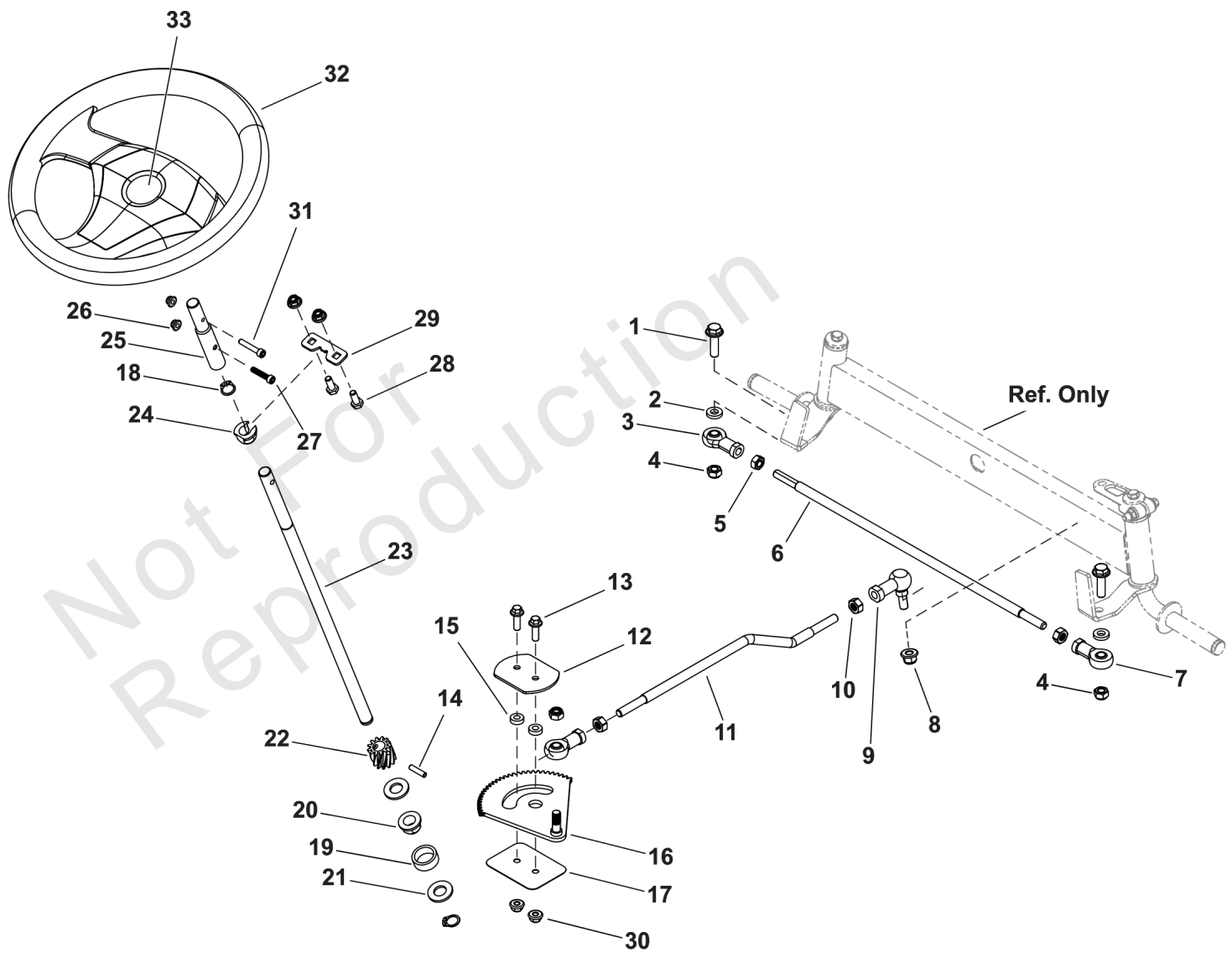

Steering Group

REF NO	PART NO	QTY	DESCRIPTION
1	-----	2	BOLT, HEX FLANGE - M10x35
2	-----	2	WASHER, FLAT 10.1 ID x 20 OD x 4MM
3	80100811	1	ROD END BEARING - L.H.
4	80100706	3	LOCKNUT HEX M10x1.25
5	80100705	1	NUT, M10 HEX
6	-----	1	ROD, PULL
7	80100812	2	BEARING, ROD END
8	-----	1	NUT, M10 LOCKING
9	80100810	1	TIE ROD END - M10
10	-----	3	NUT, HEX M10 x 1.5
11	80101192	1	TIE ROD
12	80101196	1	PLATE, TIE - TOP
13	-----	2	BOLT, HEX FLANGE HEAD M8 x 25
14	80100801	1	ROLL PIN 6DIA X 26
15	80101189	2	BUSH, STEERING RACK
16	80101199	1	STEERING RACK
17	-----	1	PLATE, TIE - TOP
18	-----	2	CIRCLIP, EXTERNAL
19	-----	1	BUSH, NYLON
20	80100978	1	BUSH HEXAGON
21	-----	2	WASHER, FLAT 32OD x 16.5ID x 3
22	80101190	1	PINION, STEERING
23	80101188	1	STEERING COLUMN
24	80100958	1	BUSH OPEN SNAP-ON
25	-----	1	STEERING COLUMN EXTENSION ROD
26	-----	2	LOCKNUT HEX FLANGE M6
27	-----	1	SCREW, SOCKET HEAD CAP - M6x30mm
28	-----	2	BOLT, HEX HEAD - M8x20
29	-----	1	PLATE, STEERING COLUMN
30	-----	4	LOCKNUT HEX FLANGE M8
31	-----	1	SCREW, SOCKET HEAD CAP M6X35MM
32	80101197	1	STEERING WHEEL
33	80101198	1	CAP, STEERING WHEEL

Wiring Schematic

Note: Unless noted otherwise, use the standard torque specifications

Mfg. No: 2691870-00

KEY SWITCH TEST	
SW POS	CONTINUITY
1. OFF	1 + 4
2. RUN	2 + 5
3. START	2 + 3 + 5

LEGEND:
 • - NON REMOVABLE CONNECTIONS
 ○ - REMOVABLE CONNECTIONS.

IGN SWITCH FUNCTIONS	
TERM NO.	FUNCTION
1 (G)	GROUND
2 (L)	BATTERY CHARGE
3 (S)	STARTER SOLENOID
4 (M)	MAGNETO
5 (B)	BATTERY

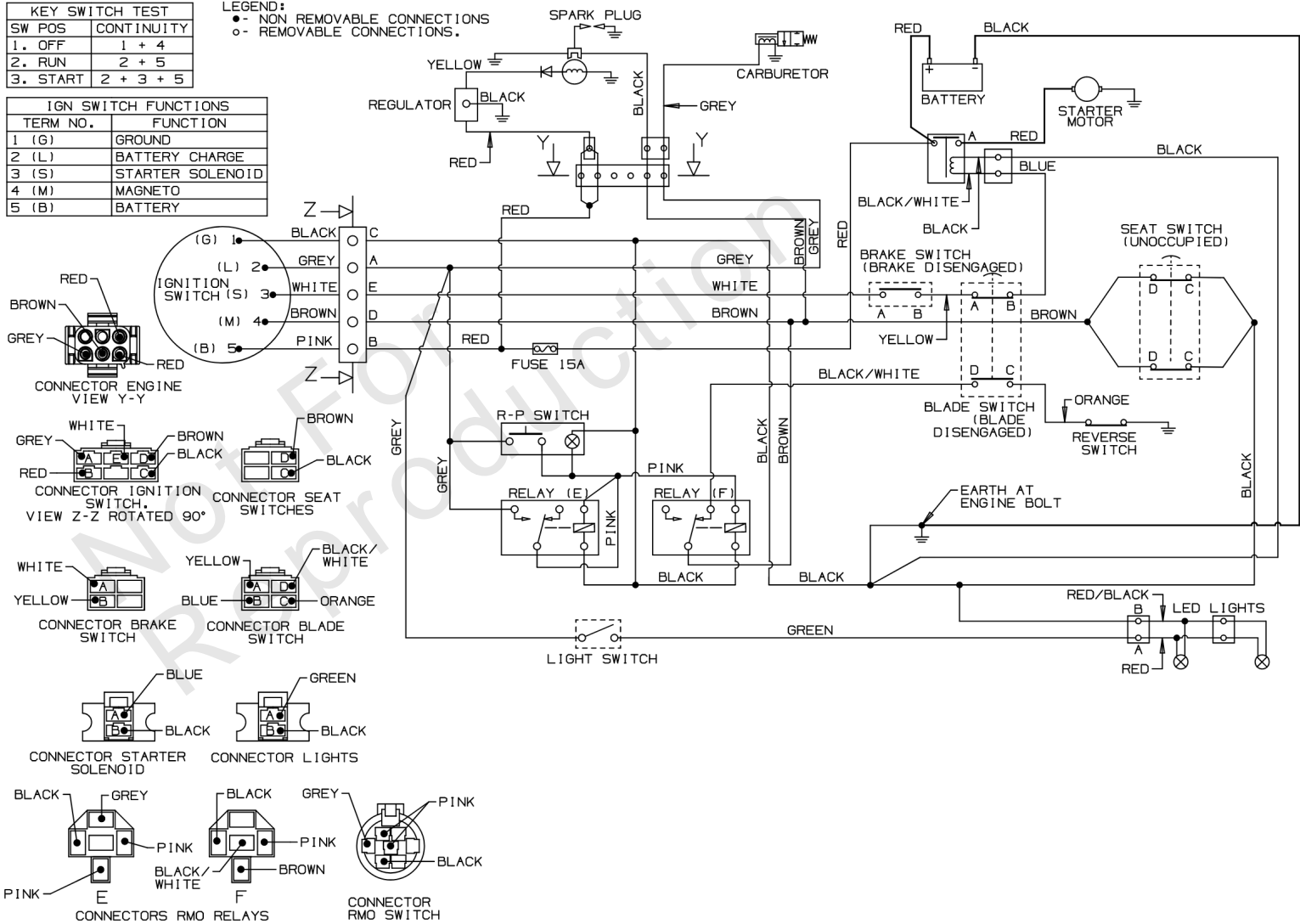

Wiring Schematic

REF NO	PART NO	QTY	DESCRIPTION
--------	---------	-----	-------------

Not For Reproduction

Wiring Schematic - Starter

Note: Unless noted otherwise, use the standard torque specifications

Mfg. No: 2691870-00

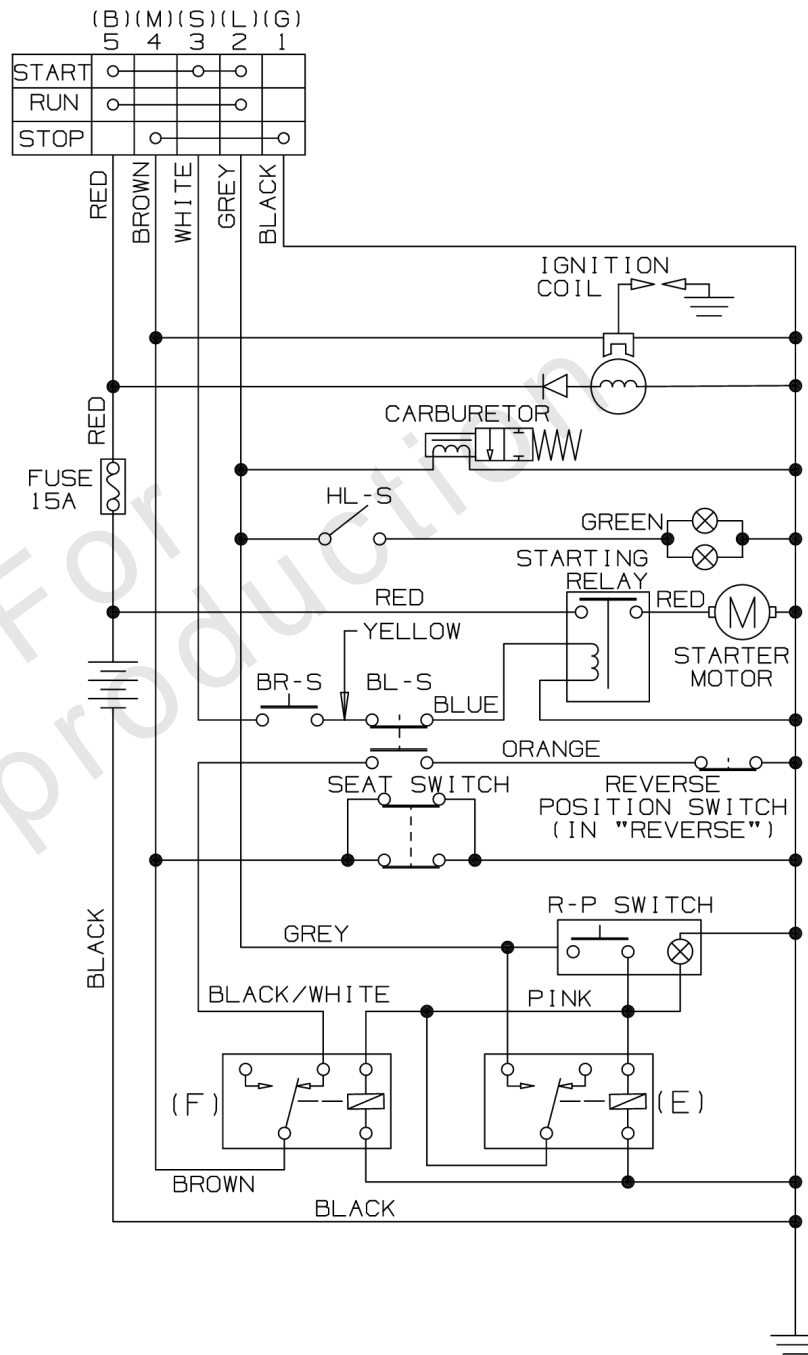

Wiring Schematic - Starter

REF NO	PART NO	QTY	DESCRIPTION
--------	---------	-----	-------------

Not For Reproduction

Hardware Identification & Torque Specifications

Torque Specification Chart								
FOR STANDARD METRIC MACHINE HARDWARE (Tolerance ± 20%)								
Property Class	5.6		8.8		10.9		12.9	
	Class 5.6		Class 8.8		Class 10.9		Class 12.9	
Size Of Hardware	in/lbs	Nm.	in/lbs	Nm.	in/lbs	Nm.	in/lbs	Nm.
	ft/lbs		ft/lbs		ft/lbs		ft/lbs	
M3	5.88	.56	13.44	1.28	19.2	1.80	22.92	2.15
M4	13.44	1.28	30.72	2.90	43.44	4.10	52.56	4.95
M5	26.4	2.50	60.96	5.75	5.97	8.10	7.15	9.7
M6	44.64	4.3	7.3	9.9	10.3	14	12.1	16.5
M7	5.2	7.1	12.1	16.5	16.9	23	19.9	27
M8	7.7	10.5	17.7	24	25	34	29	40
M10	15	21	35	48	50	67	59	81
M12	26	36	61	83	86.2	117	103	140
M14	42	58	101	132	136	185	162	220
M16	64	88	147	200	210	285	250	340
M18	89	121	202	275	287	390	346	470
M20	126	171	290	390	405	550	486	660
M22	169	230	390	530	559	745	656	890
M24	217	295	497	375	708	960	840	1140
M27	320	435	733	995	1032	1400	1239	1680
M30	435	590	995	1350	1401	1900	1681	2280
M33	590	800	1349	1830	1902	2580	2278	3090
M36	759	1030	1740	2360	2441	3310	2935	3980
M39	988	1340	2249	3050	3163	4290	3798	5150

Torque Specification Chart						
FOR STANDARD MACHINE HARDWARE (Tolerance ± 20%)						
Hardware Grade	No Marks		SAE Grade 5		SAE Grade 8	
	SAE Grade 2		SAE Grade 5		SAE Grade 8	
Size Of Hardware	in/lbs	Nm.	in/lbs	Nm.	in/lbs	Nm.
	ft/lbs		ft/lbs		ft/lbs	
8-32	19	2.1	30	3.4	41	4.6
8-36	20	2.3	31	3.5	43	4.9
10-24	27	3.1	43	4.9	60	6.8
10-32	31	3.5	49	5.5	68	7.7
1/4-20	66	7.6	8	10.9	12	16.3
1/4-28	76	8.6	10	13.6	14	19.0
5/16-18	11	15.0	17	23.1	25	34.0
5/16-24	12	16.3	19	25.8	29	34.0
3/8-16	20	27.2	30	40.8	45	61.2
3/8-24	23	31.3	35	47.6	50	68.0
7/16-14	30	40.8	50	68.0	70	95.2
7/16-20	35	47.6	55	74.8	80	108.8
1/2-13	50	68.0	75	102.0	110	149.6
1/2-20	55	74.8	90	122.4	120	163.2
9/16-12	65	88.4	110	149.6	150	204.0
9/16-18	75	102.0	120	163.2	170	231.2
5/8-11	90	122.4	150	204.0	220	299.2
5/8-18	100	136	180	244.8	240	326.4
3/4-10	160	217.6	260	353.6	386	525.0
3/4-16	180	244.8	300	408.0	420	571.2
7/8-9	140	190.4	400	544.0	600	816.0
7/8-14	155	210.8	440	598.4	660	897.6
1-8	220	299.2	580	788.8	900	1,244.0
1-12	240	326.4	640	870.4	1,000	1,360.0

The guides and ruler furnished below are designed to help you select the appropriate hardware.



Nut, M8

Thread Diameter (mm)

Inside Diameter (in) Threads per inch

Nut, 1/2-16



Screw, M8- 1.25 x 25

Thread Diameter (mm) Distance between threads (mm) Body Length (mm)

Body Diameter Threads per inch Body Length (in)

Screw, 1/2- 16 x 2



Standard Hardware Sizing

When a washer or nut is identified as 1/2" (M8), this is the *Nominal size*, meaning the *inside diameter* is 1/2 inch (8mm metric thread diameter); if a second number is present it represents the *threads per inch* (distance between threads).

When bolt or capscrew is identified as 1/2 - 16 x 2" (M8 - 1.25 x 50), this means the *Nominal size*, or body diameter is 1/2 inch (8mm metric thread diameter), the second number, 16, represents the *threads per inch*, (*distance between threads*). The final number is the body length of the bolt or screw, 2 inches (50mm).

NOTES

- These torque values are to be used for all hardware excluding: locknuts, self-tapping screws, thread forming screws, sheet metal screws and socket head setscrews.
- Recommended seating torque values for locknuts:
 - for prevailing torque locknuts - use 65% of grade 5 torques.
 - for flange whizlock nuts and screws - use 135% of grade 5 torques.
- Unless otherwise noted on assembly drawings, all torque values must meet this specification.

Common Hardware Types

Hex Head Capscrew



Washer



Carriage Bolt



Hex Nut

Wrench & Fastener Size Guide

1/4" Bolt or Nut Wrench—7/16"	5/16" Bolt or Nut Wrench—1/2"	3/8" Bolt or Nut Wrench—9/16"	7/16" Bolt or Nut Wrench (Bolt)—5/8" Wrench (Nut)—11/16"	1/2" Bolt or Nut Wrench—3/4"
M6 Bolt or Nut Wrench—10mm	M8 Bolt or Nut Wrench—13mm	M10 Bolt or Nut Wrench—17mm	M12 Bolt or Nut Wrench—19mm	M14 Bolt or Nut Wrench—22mm

VICTA