

BWM[®] Products

Pressure Washer User's Manual

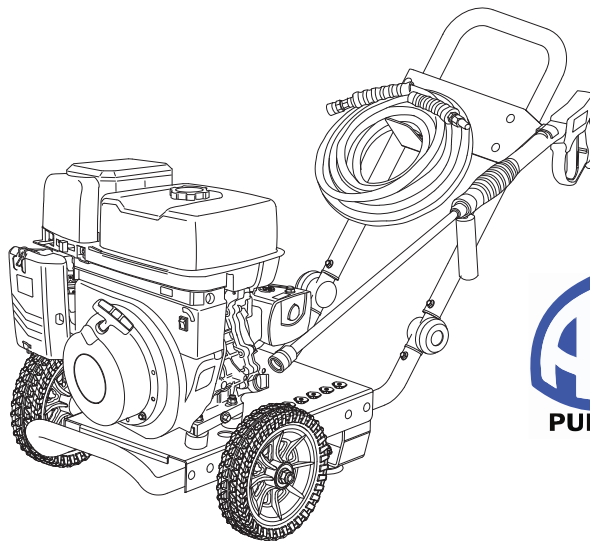

Commercial Series

Models

**PWC2500 / PWC2500H / PWC3600 / PWC3600H /
PWC4000 / PWC4000H / PWC4000RG**

Please read through this owner's manual carefully before using the product, to ensure the safety of yourself and others.

*Due to continuing improvements, actual product may differ slightly from the product described herein.

Operator Safety

Equipment Description



Read this manual carefully and become familiar with your pressure washer. Know its applications, its limitations, and any hazards involved.

Every effort has been made to ensure that information in this manual is accurate and current. However, we reserve the right to change, alter, or otherwise improve the product and this document at any time without prior notice.

Safety Rules



This is the safety alert symbol. It is used to alert you to potential personal injury hazards. Obey all safety messages that follow this symbol to avoid possible injury or death.

The safety alert symbol (▲) is used with a signal word (DANGER, CAUTION, WARNING), a pictorial and/or a safety message to alert you to hazards. **DANGER** indicates a hazard which, if not avoided, *will* result in death or serious injury. **WARNING** indicates a hazard which, if not avoided, *could* result in death or serious injury. **CAUTION** indicates a hazard which, if not avoided, *might* result in minor or moderate injury. **NOTICE**, indicates a situation that could result in equipment damage. Follow safety messages to avoid or reduce the risk of injury or death.

 WARNING
The engine exhaust from this product contains chemicals known to the State of California to cause cancer, birth defects, or other reproductive harm.

Hazard Symbols and Meanings

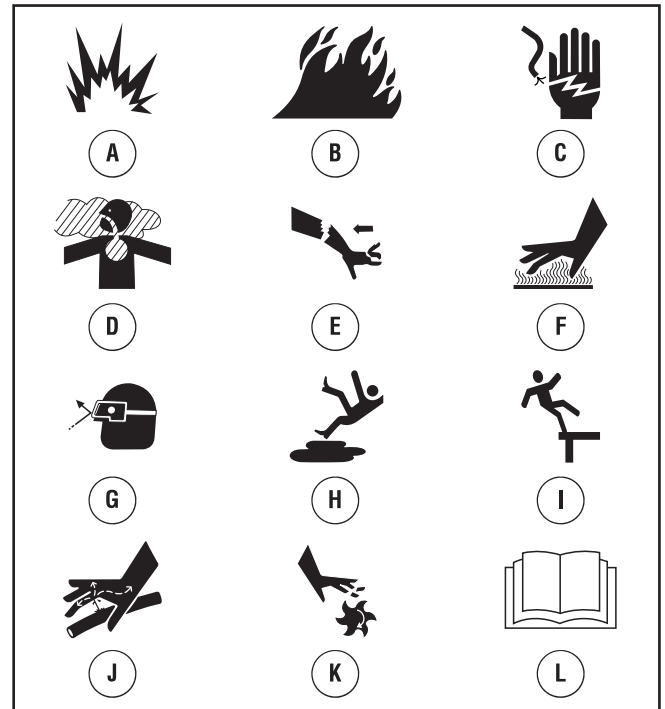

- A - Explosion
- B - Fire
- C - Electric Shock
- D - Toxic Fumes
- E - Kickback
- F - Hot Surface

- G - Flying Objects
- H - Slippery Surface
- I - Fall
- J - Fluid Injection
- K - Moving Parts
- L - Read Manual



HIGH PRESSURE SPRAY CAN CAUSE SERIOUS INJURY

Never point or aim the gun/wand at yourself or anyone else.
Never put your hand, fingers or body directly in front of the spray nozzle.

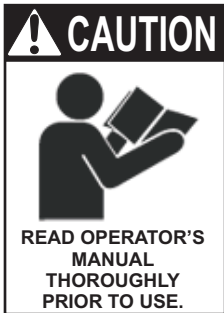

A. KNOW YOUR PRESSURE WASHING EQUIPMENT

READ YOUR OWNERS MANUAL CAREFULLY.

Do not operate your power washer until you completely understand and can follow all operating instructions, precautions and safety rules.

Restrict the use of your power washer to users who have read, understand and can follow all operating instructions, precautions and safety rules.



B. PLAN AHEAD

1. Always wear ear protection to cut noise and eye protection and / or face shield to prevent debris from flying or ricocheting into eyes and face which could result in serious injury.
2. Dress safely in long pants and wear boots or shoes. Other protective equipment is advisable when using chemicals, cleaning detergents or other corrosive or abrasive substances.
3. Do not operate pressure washing equipment if you have consumed alcohol or taken medication.
4. Keep pets, children and bystanders a safe distance away from your work area. A minimum of 50 feet is recommended.
5. Do not spray directly at glass or fragile objects.
6. CAUTION after turning off your pressure washer and water supply, there is still high pressure water trapped in the system. You must release the pressure by triggering the gun after the engine/motor has completely stopped.
7. Know what chemicals you are using and read precautions.



PRECAUTIONS FOR GASOLINE ENGINES/ELECTRIC MOTORS



Follow all safety precautions, operating procedures and maintenance listed in your engine operator's manual which came with the pressure cleaner. This manual may be attained from your local small engine repair center.

- **DO NOT** fill the engine with gasoline when the engine is running, hot or near an open flame. **DO NOT SMOKE** .



- **DO NOT** run power washers in an enclosed area. Exhaust fumes contain poisonous carbon monoxide gas. Breathing exhaust gases can cause serious illness or death.
- **DO NOT** touch or come in contact with hot mufflers, cylinders, cooling fins or hot exhaust gases as this may result in severe burns.

Never tamper with governor spring, governor links or other components which may increase the speed (RPM) of the engine.



- **DO NOT** operate pressure cleaners in the presence of flammable vapors or gases. When servicing pressure cleaning equipment, be sure to properly dispose of any flammable materials.
- **DO NOT** make adjustments to your equipment without first removing the spark plug.
- When transporting pressure cleaners, the fuel shut-off valve must be in the closed position, to prevent fuel from spilling out.

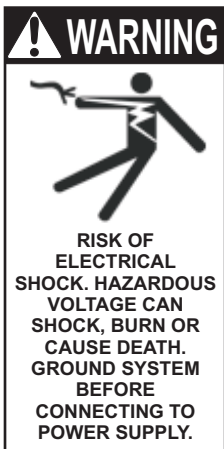

- A circuit dedicated only to the electric pressure washer is recommended. This circuit should be installed by a licensed electrician and checked to supply adequate voltage under load. If the distance from the panel is too long, the wire size is too small or the voltage is initially too low, this will cause the GFCI or Thermal overload to trip. If the GFCI trips or the thermal overload on the motor trips consult factory. Plug your cord into the receptacle. **DO NOT USE EXTENSION CORD!**
USE ONLY THE FACTORY SUPPLIED POWERCORD

INITIAL SETUP AND OPERATION OF YOUR NEW PRESSURE WASHER

Inspection for freight damage

When you receive your commercial pressure washer be sure you check for concealed freight damage. Any damage should be noted with the delivering carrier. If you have any questions related to freight call your selling dealer.

Inspection of oil levels

Check all oil levels in the pump or engine if applicable. Failure to check all levels could result in pressure washer damage. Most pumps are shipped with oil from factory and the crankcases are sealed. You may have to remove a shipping plug and install a dipstick in the pump. Oil type is stated on the pump breakdown and in the engine manual.

Water Supply

Your water supply must provide water to the equipment that exceeds the Gallon Per Minute {GPM} rate of your machine. You can check your GPM by using a 5 gallon bucket and a timer. If your machine is 5 GPM or less and the bucket fills in less than a minute you have adequate supply. Some water supply systems are affected by things like washing machines, livestock watering systems and flushing of toilets. Be sure the supply is still adequate when these operations are taking place. The water temperature cannot exceed 145 Degrees Fahrenheit on the standard models and 180 degrees Fahrenheit on the high temperature models and the pressure should not exceed 60 PSI. **Failure to secure adequate water supply to your commercial pressure washer will result in pump damage. DO NOT RUN PUMP DRY.**

Water Quality

Your water should not contain particles larger than 80 microns. Although there are small filters installed on power washers that filter the water, they could only filter poor quality water for a short period of time before they clog. This would result in damage to the machine. Therefore you should insure no sand or scale particles are present in the water supply.

Supply Hose

Hook a garden hose from the faucet to the machine, when doing this be sure to check the inlet water filter or screen. This hose should be a least 5/8" diameter and a length at least 15 feet. This 15' length helps isolate the water supply from pulsations from the pump. ***Many states require a Vacuum Break or back flow preventor be installed at the faucet, before the garden hose, to insure the water source cannot be contaminated. Be sure to check local and state regulations upon installation.***

Purge Air

Turn on the water supply and open the trigger gun, this will purge all the air from the system. Look for water leaks and stop any leak found. Leaks can cause erratic pump behavior.

Pump

Prior to turning on the power switch or starting engine, check the oil level in the pump. The pump oil should be changed after the first 50 hours of operation, then every 3 months or 300 hours of operation thereafter for average service or more frequently for extensive use or hostile environments {dusty or high moisture}.

Turn on Power

Turn on the power switch. Pull trigger gun and check for adequate pressure.

Filters

Water filters, hoses and fittings should be checked prior to every operation for cleanliness, leaks and repair needs. Repair or replace as needed.

The Unloader Valve

Pressure cleaners are built with one of two types of unloaders: The Trapped Pressure Unloader or the Flow Actuated Unloader. After the pump is filled with water, the direction of water flow must be controlled with the unloader or regulating valve. A positive displacement pump is always delivering a specific volume of water whether the spray gun is open or closed; therefore a device is needed to control the direction of flow, either to the open spray gun or redirecting the flow back to the inlet side of the pump when the spray gun is closed. Without an unloader valve, dangerously high pressure will be produced when the spray gun is closed because the water being forced out of the pump has no place to go. The unloader is used as a safety device to guard against failure of component parts, and the development of dangerously high pressures.

Hoses and Couplers

Factory supplied hoses are sized in length and diameter for best operational performance and size within the pressure capabilities. Additional hose added to the machine may change the performance of the machine. Consult factory if you have any questions. When replacing or disconnecting the quick couplers be sure the machine is shut off and relieve the pressure from all hoses.

During Operation

The pressure was set at the factory during the testing procedure, no adjustments to the machine should be required for operation. During operation do not leave the machine running for more than 2 minutes without the trigger gun being pulled. Although your machine has a by-pass valve on it and may have a thermal relief system, this can cause extensive pump damage. If machine will not be discharging water for more than 2 minutes, shut the machine off.

TIP STYLES

Chemical injector use with interchangeable tips

Your pressure washer is supplied with a downstream chemical injector. The 1/4" clear vinyl tube is be inserted into the desired chemical to apply. Be sure to use the black, low pressure nozzle to inject chemical. The chemical injector will only open up and allow chemical into the line when this tip is used. This tip enables the pressure to drop to approximately 250 PSI to draw chemical. Some injectors can be shut on and off or the rate of injection can also be set by turning the knob that the clear vinyl tube attaches to.

See calibration below. **Be sure to flush injection system with clear water after use.**

Multi-Reg (Adjustable) Tip

If your machine is supplied with an adjustable tip, the spray pattern can be changed by rotating the outer shell of the nozzle. The nozzle also will move forward and backward.

The nozzle must be pulled back toward the gun for high pressure rinse. When the nozzle is moved forward you will have low pressure and the soap injector will start to draw chemical.

Chemical injector use with multi-reg tip

Move the outer shell of your tip forward (away from the gun). This will lower your pressure and allow the injector to start to draw chemical. Chemical will only be drawn in the low pressure setting. Pull nozzle back for high pressure rinse.

Calibration

If an accurate injection rate is desired, use this formula: $(\text{GPM} \times 128) \div (\text{ounces drawn in 1 minute}) = x:1$
IE: If a 2.0 GPM machine draws 8 ounces of chemical in 1 minute: $(2 \times 128) / 8 = 32:1$

NOZZLE SELECTION GUIDE

Spray nozzle can be identified by the nozzle “number”, a five or six digit number that is stamped on the nozzle, which indicates the spray angle and orifice size. In most cases the second and third digits of the nozzle number indicate the spray angle in degrees. EXAMPLE: 00 is 0 degrees, 15 is 15 degrees and 40 is 40 degrees. The last two numbers of the nozzle number indicated the orifice size, a standard industry designation. EXAMPLE: 60 is a 6.0 orifice, 55 is a 5.5 orifice. These numbers correspond to the actual dimensions, giving the size of the orifice. They do not however directly indicate gallons per minute, flow rates or inches in diameter of the orifice. Some power washers come with an adjustable nozzle which is fixed to the end of the wand. The fan spray may be adjusted by turning the nozzle and chemicals may also be applied by pulling outward on the nozzle.

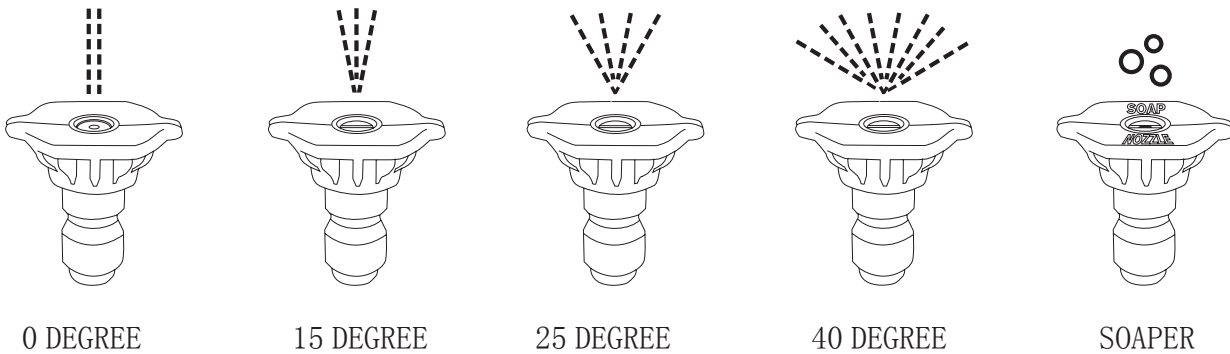

STANDARD SPRAY NOZZLE APPLICATIONS

Caution: The spray force from these nozzles can cause injuries if pointed directly at yourself or others. Before observing directly always disconnect from spray wand.

A. 0 DEGREE – BLASTING

- Removing caked on mud from heavy construction, farm or lawn equipment.
- Cleaning tar, glue or stubborn stains from concrete.
- Cleaning overhead areas.
- Removing rust from steel and oxidation from aluminum.

B. 15 DEGREE – STRIPPING

- Removing paint from wood, masonry or metal.
- Removing grease or dirt from equipment.
- Removing heavy mildew stains.
- Removing marine growth from boats and marine equipment.
- Removing rust from steel and oxidation from aluminum.

C. 25 DEGREE – CLEANING

- General cleaning of dirt, mud and grime.
- Cleaning roofs, gutters and downspouts.
- Removing light mildew stains.
- Removing algae and bacteria build-up from pools.
- Rinsing surfaces in preparation for painting.

D. 40 DEGREE – WASHING

- Light cleaning and washing.
- Washing and rinsing of automobiles and boats.
- Leaning roofs, windows, patios and driveways.

E. SOAPER – DETERGENT

- This nozzle must be used in conjunction with a cleaning detergent at low pressure. Only use this nozzle when using a detergent or cleaning solution.

⚠ WARNING	
	The high pressure stream of water that this equipment produces can cut through skin and its underlying tissues, leading to serious injury and possible amputation.
<ul style="list-style-type: none"> • Keep high pressure hose connected to pump and spray gun while system is pressurized. • Always be certain spray gun, nozzles and accessories are correctly attached. 	

2. Assemble the spray gun with the wand. Pull back the rubber piece to expose the threaded fitting. Then, screw the two pieces together and move the rubber piece back.

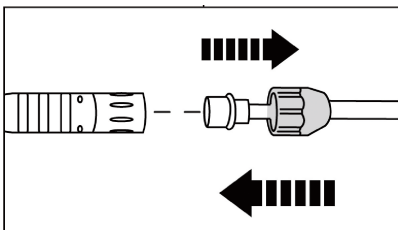

Similarly, attach other end of high pressure hose to high pressure outlet (A) on pump. Pull down on collar of quick connect, slide onto pump and let go of collar. Pull on hose to be sure of tight connection.

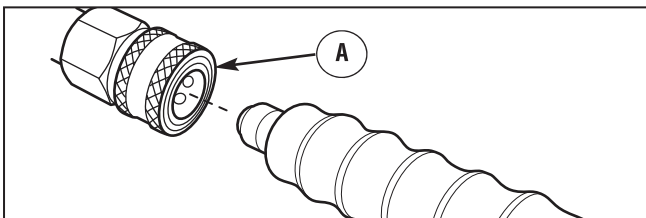

3. Before connecting garden hose to water inlet, inspect inlet screen (B). Clean screen if it contains debris or have it replaced if damaged. DO NOT run pressure washer if inlet screen is damaged.

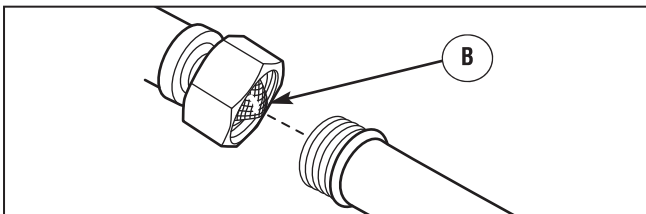

4. Run water through your garden hose for 30 seconds to clean out any debris.

IMPORTANT: DO NOT siphon standing water for the water supply. Use ONLY cold water (less than 100°F).

5. Connect the garden hose (not to exceed 50 feet in length) to the water inlet. Tighten by hand.

NOTICE	
Using a One Way Valve (vacuum breaker or check valve) at pump inlet can cause pump or inlet connector damage.	
<ul style="list-style-type: none"> • There MUST be at least ten feet (3 m) of unrestricted garden hose between the pressure washer inlet and any device, such as a vacuum breaker or check valve. • Damage to equipment resulting from failure to follow this instruction will void warranty. 	

6. Turn ON the water, squeeze the trigger on the spray gun to purge the pump system of air and impurities.

⚠ WARNING	
	Risk of eye injury. Spray can splash back or propel objects.
<ul style="list-style-type: none"> • Always wear safety goggles when using this equipment or in vicinity of where equipment is in use. • Before starting the pressure washer, be sure you are wearing adequate safety goggles. • NEVER substitute safety glasses for safety goggles. 	

Checklist Before Starting Engine

Review the unit's assembly to ensure you have performed all of the following.

1. Be sure to read the *Operator Safety* section and *How to Use Your Pressure Washer in Operation* section before using pressure washer.
2. Make sure handle is in place and secure.
3. Check that oil has been added to proper level in the engine crankcase.
4. Add proper fuel to fuel tank.
5. Check for properly tightened hose connections.
6. Check to make sure there are no kinks, cuts, or damage to high pressure hose.
7. Provide a proper water supply at an adequate flow.

Assembly procedure of handle, base plate, protection tube, support foot, bush, tire, axletree, panel, please read them carefully the operation diagram is as follows.

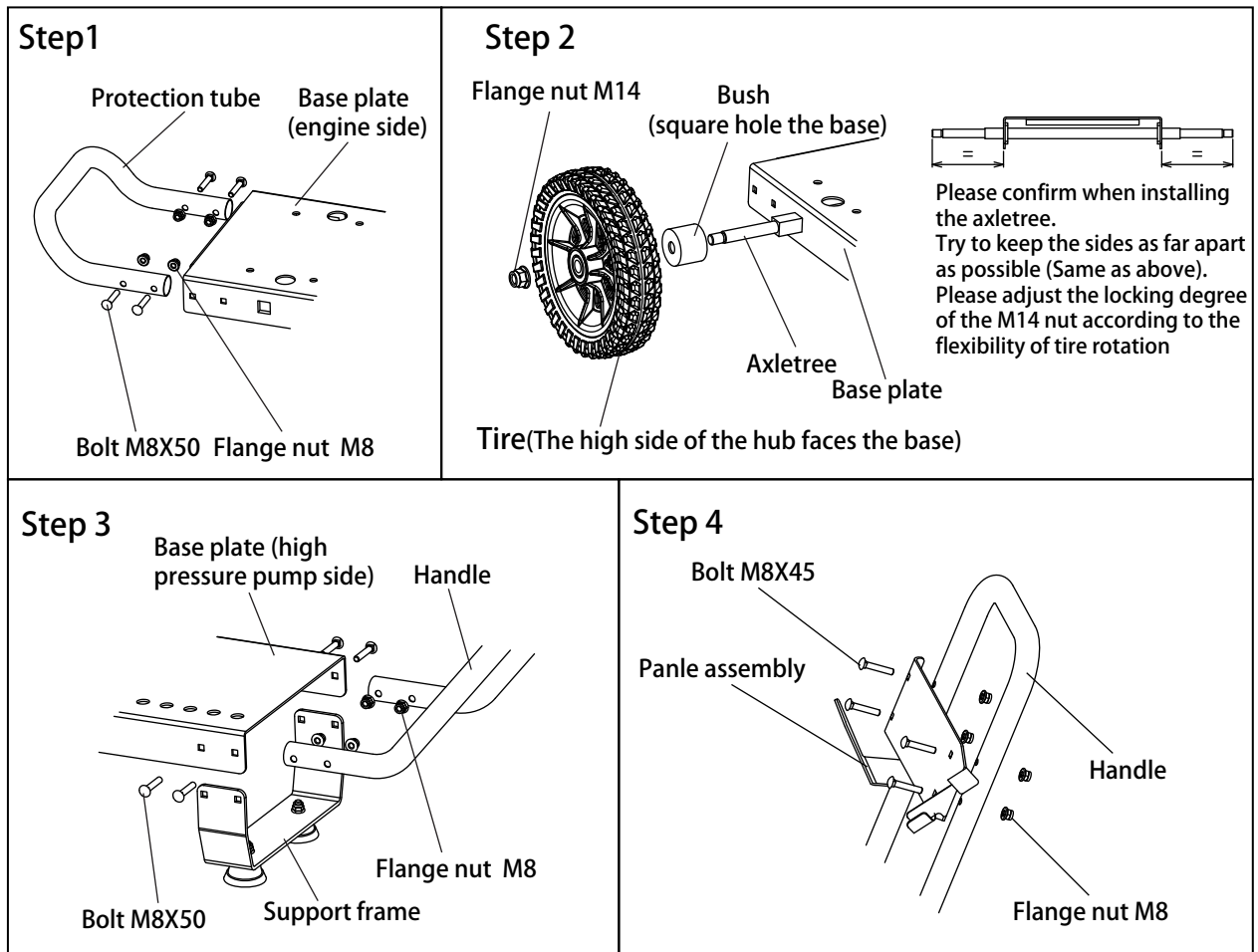

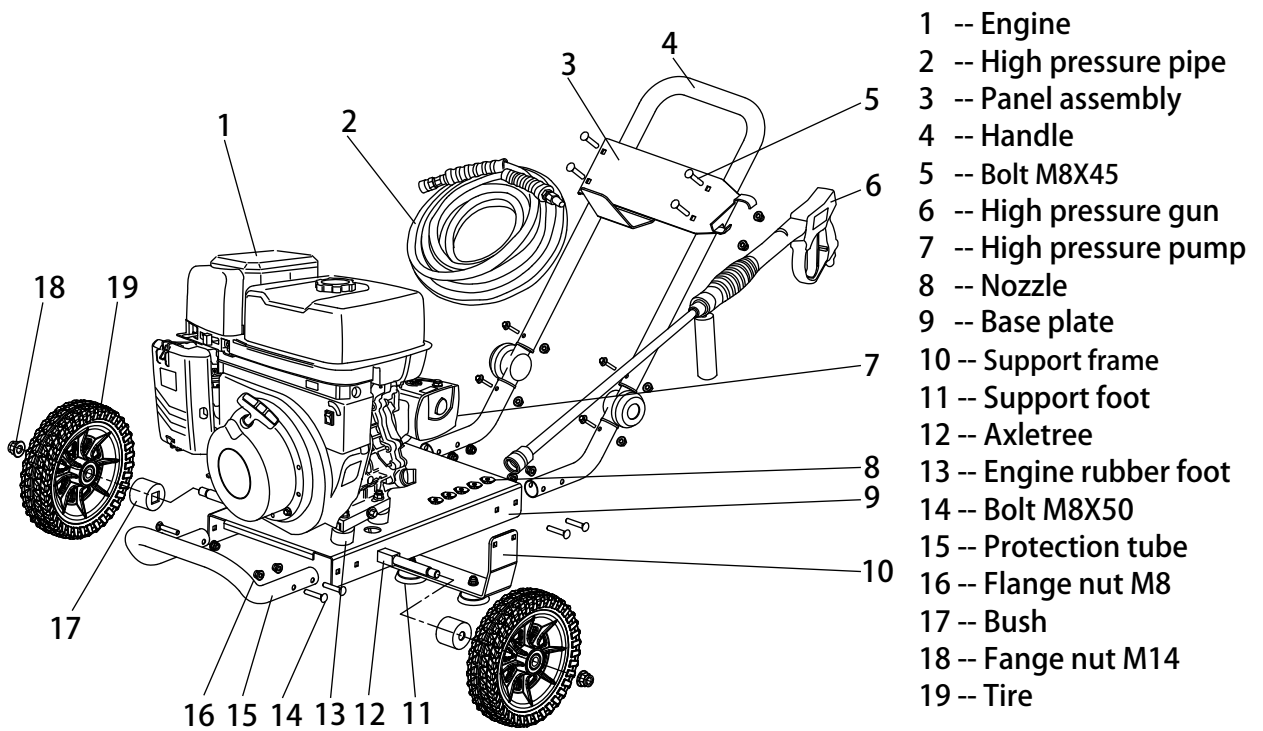

Accessory installation diagram





Operation

Pressure Washer Location

Clearances and Air Movement

 WARNING	
	Exhaust heat/gases can ignite combustibles, structures or damage fuel tank causing a fire.
<ul style="list-style-type: none"> Keep at least 5 ft. (1.5 m) clearance on all sides of pressure washer including overhead. 	

Place pressure washer outdoors in an area that will not accumulate deadly exhaust gas. DO NOT place pressure washer where exhaust gas (A) could accumulate and enter inside or be drawn into a potentially occupied building. Ensure exhaust gas is kept away from any windows, doors, ventilation intakes, or other openings that can allow exhaust gas to collect in a confined area. Prevailing winds and air currents should be taken into consideration when positioning pressure washer.

 WARNING	
	Running engine gives off carbon monoxide, an odorless, colorless, poison gas. Breathing carbon monoxide can cause headache, fatigue, dizziness, vomiting, confusion, seizures, nausea, fainting or death.
<ul style="list-style-type: none"> Operate pressure washer ONLY outdoors. Keep exhaust gas from entering a confined area through windows, doors, ventilation intakes, or other openings. DO NOT start or run engine indoors or in an enclosed area, even if windows and doors are open. 	

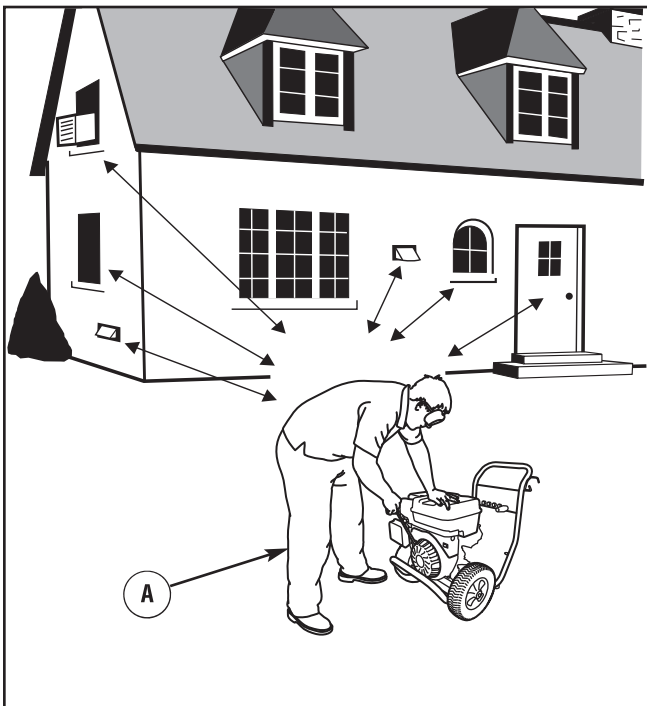

How to Start Your Pressure Washer

To start your pressure washer for the first time, follow these instructions step-by-step. This starting information also applies if you have let the pressure washer sit idle for at least a day.

- Place pressure washer outside near a water source capable of supplying water at a flow rate greater than 5.2 gallons per minute and no less than 20 PSI at pressure washer end of garden hose. DO NOT siphon supply water.
- Check that high pressure hose is tightly connected to spray gun and pump.
- Make sure unit is in a level position.
- Connect garden hose to water inlet on pressure washer pump.

NOTICE
DO NOT run the pump without the water supply connected and turned on.
<ul style="list-style-type: none"> Damage to equipment resulting from failure to follow this instruction will void warranty. Low pump inlet water pressure or flow will cause poor performance and can damage pump.

- Turn ON water, point gun in a safe direction, and squeeze trigger to purge pump system of air and impurities.
- Attach nozzle extension to spray gun.
- Choose spray tip you want to use, pull back on collar of nozzle extension, insert spray tip and release collar. Tug on spray tip to make sure it is securely in place.

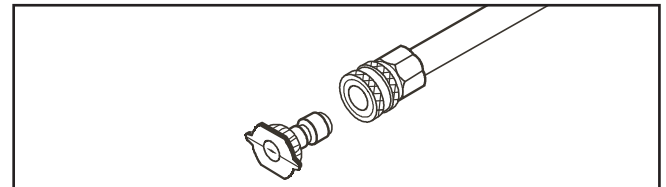

- Engage trigger lock (B) on spray gun trigger.

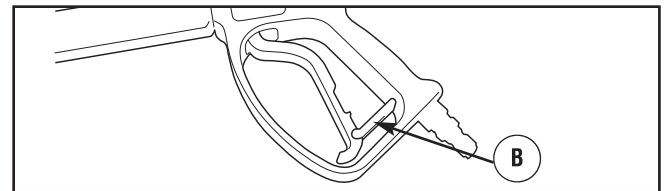

- Turn the fuel valve (C) to the "On" position.

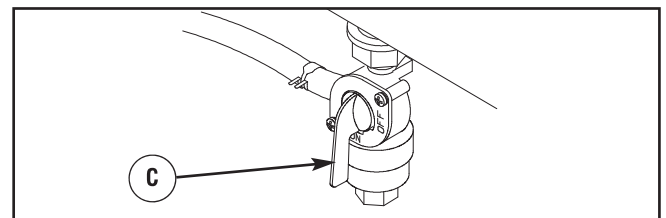

SHUT DOWN PROCEDURE

STORAGE

1. Turn off the power switch on the commercial pressure washer.
2. Relieve pressure on line by pulling trigger gun.
3. Shut off water supply and disconnect garden hose.
4. Be sure to check for water leaks or oil leaks that should be repaired before the next operation.
5. If you are going to store the machine for extended period of times in cold climates be sure to antifreeze the equipment. A 50% anti-freeze solution may be drawn in through the inlet of the pump using a short remnant of garden hose. This fluid should be run through the pump when the fluid is discharged from the pump discharge your machine is winterized. Do not allow machine to freeze.
6. Fuel stabilizer for gas if unit is to be stored for 30-90 days. If storing unit over 90 days drain fuel tank, shut off fuel valve and run unit until it stops.

PREVENT DAMAGES AND EXCESSIVE WEAR

1. Avoid extending hoses across high traffic areas while using power washers, and never leave the hose where it may be run over by vehicles of any type.
2. Never pull on the hose to move the pressure washer.
3. Never pull your pressure hose around a tight corner or force it into a small loop. The wire braid hose has a minimum bend radius of 5", and should not be forced into any small bend.
4. Wrap up the pressure washer hose when finished cleaning and store it on a hose hook, hanger, reel or other safe location.
5. Check oil levels (pump & engine) at every fueling to prevent low oil damage.
6. Inspect inlet water filter for cleanliness and damage. If soiled or dirty, rinse with fresh water. If damaged, replace with new filter.
7. When lifting or transporting power washers, secure and lift only with appropriate lifting handles.

PRESSURE WASHER CARE

1. Follow recommended service instructions in owner manual for engine.
2. Change oil in pump after the first 50 working hours (break in period) and then every 3 months or 300 hours of operation. The oil drain bolt is located on the bottom side of the pump. When refilling or adding oil to your pump, the pressure cleaner should be on level ground. Most pressure cleaners have a site glass located on the side of pump, the oil level must be in the center of the site glass. See pump manufacturer specification sheet for proper lubrication.
3. Prevent pump from freezing during freezing conditions. Flush pump with 1 to 1 mixture of automobile anti-freeze and water. This will also act as a lubricant.

TROUBLESHOOTING - COMMON PROBLEMS AND SOLUTIONS

Low Nozzle Pressure

Low nozzle pressure is a common complaint. In a majority of instances, low nozzle pressure is generally caused by one of the following:

1. Obstructed or clogged nozzle tip.
2. Obstructed or clogged inlet filter.
3. Unloader valve stuck open due to debris lodged under the check valve ball.
4. Customer use of shutoff-type quick connectors.
5. Plugged or obstructed hose.
6. Insufficient flow in gallons per minute (not pressure) to the pump.

Why should I keep my nozzles clean?

Clogged nozzles can increase pump back pressure and possibly damage the pump. Immediate attention is required.

How do I clean clogged nozzles?

1. Always disconnect your spray wand from the gun before cleaning your nozzles!
2. Clear the nozzle with a small rigid piece of wire such as a paper clip.
3. Flush the nozzle backwards with water.
4. Reconnect the wand to the gun.
5. Restart the pressure washer and depress the trigger on the spray gun.

If the nozzle is still plugged or partially plugged, repeat number 1-4. If the previous procedure does not clear the nozzle, replace with a new nozzle.

Surging Operation

Another condition is that pressure surges. That is, when the trigger is pulled, pressure is satisfactory for a moment then falls off. When the trigger is released, pressure builds up to normal levels. This is generally a sign that the water supply cannot provide the flow rate (gallons per minute) required by the pump. Following are some possible solutions:

1. Make sure the supply is not restricted; that there are no under-sized fittings and the inlet screen is unobstructed.
2. Make sure the flow rate of the water supply is sufficient for the pump. First, find the capacity of your pump in gallons per minute (gpm). Then determine the flow rate of your supply by measuring the gallons that can be delivered in one minute. If your supply does not deliver the gpm your pump requires, do not use the pump. It will suck air, causing cavitations which can quickly damage pump components.
3. Check for leaks in the supply fittings. Any leak will cause the pump to draw air and perform poorly.

Soap Injector Not Working Properly

When a soap injector is not working properly, the problem is generally fairly easy to isolate. Check the following:

1. If you have interchangeable tips, make sure the Black, soap tip is installed. Soap injectors will not work when high pressure nozzles are installed.
2. Be sure that the soap injector valve is turned on, and turn selector valve to desired setting.

3. A piece of debris may be caught in the injector valve, injector ball valve, or orifice. Disassemble and clean the injector.
4. If you have an adjustable nozzle, be sure it is in the low pressure position (away from the gun) to draw soap.

Notice

User maintenance procedures include replacing valves and seals. Unloader components are not user serviceable. Repairs involving unloaders and crankcase components should be referred to the factory or a factory authorized repair center.

TROUBLESHOOTING

PROBLEM	POSSIBLE CAUSE	SOLUTION
LOW OPERATING PRESSURE	Faulty pressure gauge	Install new gauge
	Insufficient water supply	Use larger supply hose; clean filter at water inlet
	Old, worn or incorrect spray nozzle	Match nozzle number of machine and/or replace with new nozzle
	Belt slippage	Tighten or replace; use correct belt.
	Plumbing or hose leak	Check plumbing system for leaks. Retape leaks with teflon tape.
	Faulty or misadjusted unloader valve	Adjust unloader for proper pressure. Install repair kit or replace when needed.
	Worn packing in pump	Install new packing kit
	Fouled or dirty inlet or discharge valves in pump	Clean inlet and discharge valves.
	Worn inlet or discharge valves	Replace with valve kit.
	Obstruction in spray nozzle	Remove obstruction.
	Leaking pressure control valve	Rebuild or replace as needed.
	Slow engine RPM	Set engine speed at proper specifications.
	Pump sucking air	Check water supply and possibility of air seepage.

PROBLEM	POSSIBLE CAUSE	SOLUTION
LOW OPERATING PRESSURE	Valves sticking	Check and clean or replace if necessary.
	Unloader valve seat faulty	Check and replace if necessary.
FLUCTUATING PRESSURE	Valves worn	Check and replace if necessary.
	Blockage in valve	Check and replace if necessary.
	Worn piston packing	Check and replace if necessary.
NOISY PUMP	Air in suction line	Check water supply and connections on suction line.
	Broken or weak inlet or discharge valve springs	Check and replace if necessary.
	Excessive matter in valves	Check and clean if necessary.
	Worn bearings	Check and replace if necessary.
PRESENCE OF WATER IN OIL	Water seal worn	Check and replace if necessary and change oil.
	High humidity in air	Check and change oil twice as often.
WATER DRIPPING FROM UNDER PUMP	Piston packing worn	Check and replace if necessary.
	O-Ring plunger retainer worn	Check and replace if necessary.
	Cracked piston	Check and replace if necessary.
	Pump protector	Lower water supply pressure. Do not run with spray gun closed longer than 2 minutes.
OIL DRIPPING	Oil seal worn	Check and replace if necessary.
EXCESSIVE VIBRATION IN DELIVERY LINE	Irregular functioning of the valves	Check and replace if necessary.
DETERGENT NOT DRAWING	Air leak	Tighten all clamps. Check detergent lines for holes.
	Filter screen on detergent suction hose plugged	Clean or replace.

PROBLEM	POSSIBLE CAUSE	SOLUTION
DETERGENT NOT DRAWING	Incorrect nozzle or adjustable nozzle in wrong position.	Install chemical nozzle or push adjustable nozzle forward (away from gun).
	Dried up detergent plugging metering valve injector	Disassemble and clean thoroughly.
	High viscosity of detergent	Dilute detergent to specifications.
	Hole in detergent line(s)	Repair hole.
	Low detergent level	Add detergent, if needed.
PUMP RUNNING NORMALLY BUT PRESSURE LOW ON INSTALLATION	Pump sucking air	Check water supply and possibility of air seepage.
	Valves sticking	Check and clean or replace if necessary.
	Nozzle incorrectly sized	Check and replace if necessary
	Unloader valve seat faulty	Check and replace if necessary.
	Worn piston packing	Check and replace if necessary.
RELIEF VALVE LEAKS WATER	Relief valve defective	Replace or repair.
ENGINE WILL NOT START OR CRANK OVER	Battery dead.	Charge or replace battery, add electrolyte if battery is new.
	Pressure built up in system	Squeeze trigger gun to relieve pressure.
	Dirty battery connection	Clean connections.
	Battery cables disconnected	Clean.
	Engine, pump, or gearbox is seized	Replace or repair seized part.
	Keyswitch, solenoid and starter on engine defective	Repair or replace.
ENGINE WILL NOT START BUT WILL CRANK OVER	Engine power switch is off or defective	Check engine power switch.
	Dirty or fowled spark plug	Replace spark plug.

PROBLEM	POSSIBLE CAUSE	SOLUTION
ENGINE WILL NOT START BUT WILL CRANK OVER	Low oil shut down is activated	Add oil to engine, check more frequently.
	Engine low or out of fuel	Add Fuel.
	Fuel filter is clogged	Replace or clean fuel filter.
	Fuel supply valve-off	Turn on fuel supply valve.
	Engine flooded or starved	Choke only as required.
ENGINE BOGS DOWN UNDER LOAD, WHENEVER SPRAY GUN IS TRIGGERED	Incorrect or obstructed nozzle	Replace with the proper nozzle or clear obstruction.
	Engine needs to be repaired or replaced	See engine manual or engine dealer.
	Operating in high elevation	Lower the pressure of the unit and check for correct engine speed (RPM)
	Carbon deposits on cylinder head	Remove head and wire brush deposits.
ELECTRIC MOTOR DOES NOT START	No electric power	Check cord, plug, socket, and breaker.
	Thermal overload in the motor or starter has been tripped	Reset manual overload by depressing the thermal switch on the outside of the motor or starter after the motor has cooled.
	Power switch inoperative	Check power switch.
	Electric motor or wiring failure	Replace or repair motor and/or wiring.

Maintenance

Maintenance Schedule

Follow the hourly or calendar intervals, whichever occurs first. More frequent service is required when operating in adverse conditions noted below.

Maintenance Schedule - Fill in Dates as You Complete Regular Service								
Maintenance Task	Service Dates					Service Dates		
	Before Each Use	Every 25 Hours or Yearly	Every 50 Hours or Yearly	Every 100 Hours or Yearly	Every 250 Hours or Yearly			
Pressure Washer								
Check/clean water inlet screen	X							
Check high pressure hose	X							
Check detergent siphoning hose/filter	X							
Check spray gun and hose assembly for leaks	X							
Check engine and pump each time	Ensure engine and pump in good working conditions							
Engine								
Check oil level	X							
Inspection and check fuel and oil leaks	X							
Change engine oil		Only the first time	X					
Clean muffler cover and recoil starter	X							
Check and clean air filter	X							
Service spark plug			X					
Check and clean fuel cock			X					
Remove carbon in combustion chamber					X			
Check and adjustment of valve clearance					X			
Replace the fuel pipes	3 years (or when necessary)							

1 Clean if clogged. Replace if perforated or torn.

2 Change oil after the first 25 operating hours and every 50 hours or yearly thereafter. Change oil sooner when operating under dirty or dusty conditions.

3 Replace more often under dirty or dusty conditions.

Pump Preventative Maintenance Check List					
Follow the daily, hourly or calendar intervals, whichever occurs first.					
Maintenance Item:	Daily	Each 50 hours	Each 500 hours	Each 1000 hours	Remarks
Check Pump Oil Level/Quantity	X				
Check for Oil Leaks and Water Leaks	X				
Check Filter	X				
Check connection(pipes,coupling)		X			
Oil Change		Only the first time	X		
Seal Change				X	
Valve Change				X	
Check Accessories				X	

** Each system's maintenance cycle will be exclusive. If system performance decreases, check immediately. If no wear at 1000 hours, check again at 2000 hours and each 500 hours until wear is observed. Valves typically require changing every other seal change. Duty cycle, temperature, quality of pumped liquid and inlet feed conditions all affect the life of pump wear parts and service cycle. Remember to service the unloader at each seal servicing and check all system accessories and connections before resuming operation.

NOTES

